



**P&E MINING
CONSULTANTS INC.**

Geologists and Mining Engineers

201 County Court Blvd., Suite 304
Brampton, Ontario
L6W 4L2

Tel: 905-595-0575
Fax: 905-595-0578
www.peconsulting.ca

**PRELIMINARY ECONOMIC ASSESSMENT
OF THE
FREMONT GOLD PROJECT, MARIPOSA COUNTY,
CENTRAL CALIFORNIA, USA**

**UTM NAD83 ZONE 10N 754,360 m E, 4,164,460 m N
LONGITUDE 120° 07' W and LATITUDE 37° 36' N**

**FOR
STRATABOUND MINERALS CORP.**

**NI 43-101 & 43-101F1
TECHNICAL REPORT**

**Andrew Bradfield, P.Eng.
Jarita Barry, P.Geo.
Fred Brown, P.Geo.
D. Grant Feasby, P.Eng.
Eugene Puritch, P.Eng., FEC, CET
Greg Robinson, P.Eng.
Kirk Rodgers, P.Eng.
William Stone, Ph.D., P.Geo.
Travis Manning, P.E., Kappes, Cassidy & Associates**

**P&E Mining Consultants Inc.
Report 437**

**Effective Date: February 15, 2023
Signing Date: March 31, 2023**

TABLE OF CONTENTS

1.0	SUMMARY	1
1.1	Property Description, Location, Access and Physiography	1
1.2	History	2
1.3	Geology, Mineralization, and Deposit Type	2
1.4	Exploration	3
1.5	Drilling	4
1.6	Sample Preparation, Analyses, Security and Verification	4
1.7	Mineral Processing and Metallurgical Testing	4
1.8	Mineral Resource Estimate	5
1.9	Mining Methods	7
1.10	Recovery Methods	8
1.11	Project Infrastructure	8
1.12	Market Studies and Contracts	8
1.13	Environmental Studies, Permits and Social or Community Impact	8
1.14	Capital and Operating Costs	9
	1.14.1 Capital Costs	9
	1.14.2 Operating Costs	10
	1.14.3 Other Costs	11
1.15	Economic Analysis	11
1.16	Adjacent Properties	13
1.17	Risks and Opportunities	13
1.18	Conclusions	13
1.19	Recommendations	14
2.0	INTRODUCTION AND TERMS OF REFERENCE	16
2.1	Terms of Reference	16
2.2	Site Visits	16
2.3	Sources of Information	17
2.4	Units and Currency	17
3.0	RELIANCE ON OTHER EXPERTS	26
4.0	PROPERTY DESCRIPTION AND LOCATION	27
4.1	Location	27
4.2	Property Acquisition, Mineral Rights and Tenure	27
4.3	Royalties and Other Encumbrances	30
4.4	Permitting and Environmental	30
5.0	ACCESSIBILITY, CLIMATE, LOCAL RESOURCES, INFRASTRUCTURE AND PHYSIOGRAPHY	31
5.1	Access	31
5.2	Climate	32
5.3	Local Resources	32
5.4	Infrastructure	32
5.5	Physiography	32
6.0	HISTORY	35
6.1	Prior Ownership History	36
6.2	Historical Mineral Exploration	37
	6.2.1 1984 to 2013	37

6.2.2	2013 to 2021 California Gold	46
6.2.2.1	Geological Mapping.....	46
6.2.2.2	Surface Sampling	47
6.2.2.3	Airborne Geophysical Survey.....	48
6.3	Historical Mineral Resource and Mineral Reserve Estimates	48
6.3.1	Pine Tree-Josephine Deposit.....	48
6.3.1.1	International Geosystems Corporation	48
6.3.1.2	Wright Engineers (1986).....	49
6.3.1.3	Derry, Michener, Booth and Wahl (1988).....	50
6.3.1.4	Northwest 1988.....	51
6.3.1.5	Beacon Hill 1988	51
6.3.1.6	Precision Gold (2008).....	52
6.3.2	Queen Specimen Deposit.....	53
6.4	Recent and Previous Mineral Resource Estimates.....	54
6.4.1	RPA 2016 Mineral Resource Estimate	54
6.4.2	SLR 2021 Mineral Resource Estimate.....	54
6.5	Past Production	55
6.6	Historical Feasibility Studies	56
6.7	Historical Underground Studies.....	57
6.8	Historical Environmental Studies	57
7.0	GEOLOGICAL SETTING AND MINERALIZATION	59
7.1	Regional Geology	59
7.2	regional Gold Districts	59
7.3	Property Geology	62
7.4	Structural Geology	64
7.5	Deposit Geology	70
7.5.1	Pine Tree-Josephine Deposit.....	71
7.5.2	Queen Specimen Deposit.....	71
7.6	Mineralization	71
7.7	Other Gold Deposits of Interest	74
7.7.1	Chicken Gulch Deposit.....	74
7.7.2	Crown Point Deposit.....	76
8.0	DEPOSIT TYPES	77
9.0	EXPLORATION.....	80
9.1	Soil Geochemistry Survey	80
9.2	Surface Trenching.....	82
9.3	Drill Road Channel Sampling.....	84
9.4	2022 LiDAR™ Survey	86
9.5	Exploration Potential	87
10.0	DRILLING.....	93
10.1	Historical Drilling Programs.....	93
10.2	Recent Drilling Programs	94
10.2.1	Pine Tree-Josephine Drilling: 2013-2016.....	96
10.2.1.1	Phase I Drilling 2013	96
10.2.1.2	Phase II Drilling 2014.....	99
10.2.1.3	Phase III Drilling 2015-2016	102
10.2.2	Queen Specimen Drilling.....	111

	10.2.2.1	Queen Specimen Drilling 2015-2016	111
	10.2.2.2	Queen Specimen Drilling 2017-2018	115
11.0		SAMPLE PREPARATION, ANALYSIS AND SECURITY	122
11.1		Historical Sample Preparation, Analyses and Security.....	122
	11.1.1	Goldenbell Reverse Circulation (1985 to 1986).....	122
	11.1.2	Precision Gold LLC Tailings Sampling (2008).....	123
	11.1.3	California Gold Core Drilling (2013 to 2018).....	123
11.2		Stratabound Pine Tree-Josephine Trenching (2022).....	124
11.3		Bulk Density Data.....	124
11.4		Historical Quality Assurance/Quality Control Review.....	125
	11.4.1	Goldenbell RC (1985 to 1986).....	125
	11.4.2	Precision Gold LLC Tailings Sampling (2008).....	126
	11.4.3	California Gold Core Drilling (2013 to 2018).....	126
	11.4.3.1	Performance of Certified Reference Materials	126
	11.4.3.2	Performance of Blank Material.....	129
	11.4.3.3	Performance of Lab Duplicates	130
11.5		Stratabound Quality Assurance/Quality Control Review	131
	11.5.1	Stratabound Trenching (2022).....	131
	11.5.1.1	Performance of Certified Reference Materials	131
	11.5.1.2	Performance of Blank Material.....	133
	11.5.1.3	Performance of Duplicates.....	134
11.6		California Gold Umpire Assaying	136
11.7		Conclusion	137
12.0		DATA VERIFICATION	138
12.1		Drill Hole and Trench Assay Verification	138
12.2		Drill Hole and Trench Data Verification	138
12.3		2022 P&E Site Visit and Independent Sampling.....	138
12.4		California Gold 2013 Drill Hole Twinning Program.....	139
12.5		Conclusion	140
13.0		MINERAL PROCESSING AND METALLURGICAL TESTING	141
13.1		Previous Operations.....	141
13.2		Test work Program.....	141
13.3		Scoping Test Work	143
13.4		Historical Test Work Details	148
	13.4.1	Samples	148
	13.4.2	Grinding	148
	13.4.3	Flotation and Concentrate Dewatering	149
	13.4.4	Gravity Concentration.....	154
	13.4.5	Treatment of Carbon Removal Products.....	154
	13.4.6	Roasting and Calcine Leaching	155
	13.4.7	Sulphur Dioxide Absorption Capacity of Flotation Tailings.....	158
	13.4.8	Bioleaching	158
	13.4.9	Heap Leaching of Oxide Mineralized Material	161
13.5		2014 Test Work.....	164
	13.5.1	Comminution Testing	165
	13.5.2	Flotation Tests.....	165
	13.5.2.1	Rougher Flotation Kinetic Tests.....	165

	13.5.2.2	Rougher-Cleaner Circuit Flotation Tests	167
	13.5.3	Gravity Concentration.....	169
	13.5.4	Combined Gravity Separation and Flotation Tests.....	169
	13.5.5	Cyanidation Tests.....	170
	13.5.5.1	Bottle Roll Direct Cyanide Leach Tests	170
	13.5.5.2	Bottle Roll Carbon-in-Leach (CIL) Tests	171
	13.6	Conclusions.....	171
14.0		MINERAL RESOURCE ESTIMATES	173
	14.1	Introduction.....	173
	14.2	Data Supplied.....	173
	14.3	Database Validation.....	175
	14.4	Economic Assumptions	179
	14.5	Domain Modelling.....	179
	14.6	Exploratory Data Analysis.....	182
	14.7	Bulk Density	184
	14.8	Compositing.....	184
	14.9	Composite Data Analysis.....	184
	14.10	Treatment of Extreme Values	189
	14.11	Variography	189
	14.12	Block Model.....	190
	14.13	Grade Estimation and Classification.....	191
	14.14	Mineral Resource Estimate.....	192
	14.15	Grade Sensitivity.....	196
	14.16	Validation	197
15.0		MINERAL RESERVE ESTIMATES.....	200
16.0		MINING METHODS	201
	16.1	Open Pit Mining.....	201
	16.1.1	Open Pit Optimizations.....	202
	16.1.2	Pit Designs	204
	16.1.2.1	Geotechnical Studies.....	207
	16.1.2.2	Hydrogeological Studies.....	207
	16.1.2.3	Mining Dilution and Losses.....	208
	16.1.3	Open Pit Mining Schedule	209
	16.1.4	Open Pit Mining Practices	210
	16.1.4.1	Waste Rock Storage.....	215
	16.1.4.2	Mine Support Facilities.....	216
	16.2	Underground Mining	216
	16.2.1	Introduction.....	216
	16.2.2	Mine Planning Criteria.....	220
	16.2.2.1	Mining Parameters	220
	16.2.2.2	Railveyor™.....	221
	16.2.2.3	Cut-off Grade	223
	16.2.2.4	Deswik Stope Optimizer (DSO)	223
	16.2.3	Geotechnical Considerations	223
	16.2.3.1	Stope Sizing	224
	16.2.3.2	Crown.....	224
	16.2.3.3	Pit Pillar / Zone of Influence.....	224

	16.2.3.4	Artificial Sill Pillars	224
	16.2.3.5	Stand-off to Historical Workings.....	224
	16.2.4	Development.....	225
	16.2.4.1	Lateral Development.....	226
	16.2.4.2	Vertical Development	226
	16.2.5	Production.....	227
	16.2.5.1	Mining.....	227
	16.2.5.2	Dilution	227
	16.2.5.3	Mining Loss	228
	16.2.5.4	Material Handling	228
	16.2.6	Mine Services.....	229
	16.2.6.1	Backfill.....	229
	16.2.6.2	Ventilation.....	230
	16.2.6.3	Dewatering.....	231
	16.2.6.4	Electrical Power	232
	16.2.6.5	Other Infrastructure.....	232
	16.2.7	Equipment	235
	16.2.8	Personnel.....	235
	16.2.9	Mine Plan	236
	16.2.10	Mine Schedule	237
	16.2.10.1	Development Schedule	237
	16.2.10.2	Production Schedule	237
	16.2.10.3	Graphical Schedule	241
	16.3	Life-of-Mine Production Schedule	246
17.0		RECOVERY METHODS.....	248
17.1		Process Description Summary	248
17.2		Flotation Concentrator	248
	17.2.1	Process Design Criteria.....	252
	17.2.2	Process Description.....	252
	17.2.2.1	Crushing.....	252
	17.2.3	Crushed Stockpile and Reclamation	253
	17.2.4	Grinding and Gravity Separation	253
	17.2.5	Flotation and Re grind	253
	17.2.6	Concentrate Dewatering.....	254
	17.2.7	Tailings	254
	17.2.8	Paste Backfill	254
17.3		Heap Leach	254
	17.3.1	Process Design Criteria.....	256
	17.3.2	Process Description.....	256
	17.3.2.1	Screening and Crushing	256
	17.3.2.2	Agglomeration, Conveying and Stacking.....	256
	17.3.2.3	Leach Pad.....	257
	17.3.2.4	Leaching Systems	257
	17.3.2.5	Solution Collection System.....	258
	17.3.2.6	Adsorption.....	258
17.4		Reagents.....	259
	17.4.1	Potassium Amyl Xanthate (PAX).....	259

	17.4.2	Aero 208.....	259
	17.4.3	Methyl Isobutyl Carbinol (MIBC).....	259
	17.4.4	Sodium Cyanide.....	259
	17.4.5	Cement.....	259
	17.5	Water.....	260
18.0		PROJECT INFRASTRUCTURE.....	262
	18.1	Infrastructure.....	262
	18.1.1	Existing Installations.....	262
	18.1.2	Access and Site Roads.....	262
	18.1.3	Project Buildings.....	263
	18.1.4	Warehouse.....	264
	18.1.5	Laboratory.....	264
	18.1.6	Fuel Storage and Dispensing.....	264
	18.1.7	Explosives Storage.....	264
	18.2	Electrical Power Supply.....	265
	18.2.1	Process Plant and Heap Leach Electrical Power Supply.....	265
	18.2.2	Site Electrical Power Distribution.....	266
	18.2.3	Backup Power.....	266
	18.3	Water.....	266
	18.3.1	Water Supply and Requirements.....	266
	18.3.2	Potable Water.....	267
	18.3.3	Fire Water and Protection.....	267
	18.3.4	Domestic Wastewater Disposal.....	267
19.0		MARKET STUDIES AND CONTRACTS.....	268
	19.1	Metal Prices and Foreign Exchange.....	268
	19.2	Contracts.....	268
20.0		ENVIRONMENTAL STUDIES, PERMITS, AND SOCIAL OR COMMUNITY IMPACTS.....	269
	20.1	Project Permitting Requirements and Status.....	269
	20.1.1	Primary Land Use Entitlements.....	269
	20.1.2	Environmental Resource Permits.....	271
	20.1.3	Site Development and Operating Permits and Approvals.....	273
	20.2	Summary of Environmental Studies.....	274
	20.2.1	Historical Environmental Studies.....	274
	20.2.2	Recent and Current Environmental Studies.....	275
	20.3	Requirements and Plans for Mine Waste Rock and Tailings Management and Disposal.....	276
	20.4	Social and Community-Related Requirements and Plans.....	278
	20.5	Mine Reclamation and Closure/Post-Closure Requirements.....	278
21.0		CAPITAL AND OPERATING COSTS.....	279
	21.1	Capital Costs.....	279
	21.2	Initial Capital Costs.....	280
	21.2.1	Open Pit Mining Equipment.....	280
	21.2.2	Open Pit Pre-production.....	280
	21.2.3	Site Infrastructure for Mining.....	280
	21.2.4	Highway 49 Realignment.....	280
	21.2.5	Process Plant and Tailings.....	281

	21.2.5.1	Process and Infrastructure Cost	281
	21.2.5.2	Capital Costs by Discipline.....	282
	21.2.5.3	Contingency	283
	21.2.5.4	Indirect and Owner's Costs.....	284
	21.2.5.5	EPCM, Initial Fills, and Working Capital	284
	21.2.6	Owner's Costs	285
	21.2.7	Contingency	285
21.3		Sustaining Capital Costs	285
	21.3.1	Open Pit Mining Equipment	285
	21.3.2	Site Infrastructure for Mining	285
	21.3.3	Tailings Storage Facility	286
	21.3.4	Heap Leach Facility	286
	21.3.4.1	Heap Leach Capital Costs by Discipline	287
	21.3.4.2	Heap Leach Contingency	288
	21.3.4.3	Heap Leach Indirect and Owner's Costs	288
	21.3.4.4	Heap Leach EPCM, Initial Fills, and Working Capital	289
	21.3.5	Underground Mine Development	289
	21.3.6	Underground Mobile Fleet and Railveyor™ System	290
	21.3.7	Underground Mine Infrastructure	291
	21.3.8	Underground Mine Project Costs.....	291
	21.3.9	Contingency	291
21.4		Operating Costs.....	291
	21.4.1	Open Pit Mining.....	292
	21.4.2	Underground Mining	293
	21.4.3	Process Plant	294
	21.4.3.1	Process Plant Labour Cost	297
	21.4.3.2	Electrical Power	297
	21.4.3.3	Consumables	298
	21.4.3.4	Maintenance	298
	21.4.3.5	Reagents	298
	21.4.4	Heap Leach Processing	298
	21.4.4.1	Heap Leach Process Labour Cost	300
	21.4.4.2	Heap Leach Electrical Power.....	301
	21.4.4.3	Heap Leach Consumables.....	302
	21.4.4.4	Heap Leach Maintenance.....	302
	21.4.4.5	Heap Leach Reagents.....	302
	21.4.4.6	Heap Leach General and Administrative Operating Costs	302
	21.4.5	Concentrate Transport.....	302
	21.4.6	General and Administration	302
21.5		Royalties	302
21.6		Closure Costs	302
21.7		Cash Costs and All-In Sustaining Costs	303
22.0		ECONOMIC ANALYSIS	304
	22.1	Parameters.....	304
	22.1.1	Gold Price	304
	22.1.2	Discount Rate.....	304
	22.1.3	Costing	304

22.1.4	Other Inputs	305
22.1.5	Royalty and Taxes.....	305
22.2	Simplified Financial Model	305
22.3	Sensitivity	307
22.4	Summary.....	308
23.0	ADJACENT PROPERTIES	309
24.0	OTHER RELEVANT DATA AND INFORMATION	310
24.1	Risks.....	310
24.1.1	Mineral Resource Estimate	310
24.1.2	Open Pit Mining.....	310
24.1.3	Underground Mining	310
24.1.4	Processing Plant and Tailings	311
24.1.5	Permitting.....	311
24.1.6	Financial Aspects	311
24.2	Opportunities.....	311
24.2.1	Mineral Resource Estimate	311
24.2.2	Mining and Processing Operations	311
24.2.3	Financial Aspects	312
25.0	INTERPRETATION AND CONCLUSIONS	313
26.0	RECOMMENDATIONS	318
27.0	REFERENCES	322
28.0	CERTIFICATES.....	326
APPENDIX A	SURFACE DRILL HOLE PLAN.....	335
APPENDIX B	3-D DOMAINS.....	338
APPENDIX C	LOG PROBABILITY PLOTS.....	341
APPENDIX D	VARIOGRAMS.....	343
APPENDIX E	BLOCK MODEL CROSS SECTIONS AND PLANS.....	345
APPENDIX F	CLASSIFICATION BLOCK MODEL CROSS SECTIONS AND PLANS	356
APPENDIX G	OPTIMIZED PIT SHELL.....	367
APPENDIX H	1985-1986 DRILL HOLE COLLAR LOCATION AND ORIENTATION	370
APPENDIX I	1985-1986 DRILL HOLE INTERCEPTS	374
APPENDIX J	2016-2017 SOIL GEOCHEMISTRY.....	385
APPENDIX K	SURFACE TRENCH ASSAYS	434

LIST OF TABLES

Table 1.1 Summary of Mineral Resource Estimate ⁽¹⁻¹²⁾	6
Table 1.2 Project CAPEX Summary	10
Table 1.3 Project OPEX Summary	11
Table 1.4 PEA Financial Results	12
Table 1.5 Recommended Work Program and Budget	15
Table 2.1 Qualified Persons Responsible for this Technical Report	17
Table 2.2 Terminology and Abbreviations	18
Table 2.3 Unit Measurement Abbreviations	24
Table 4.1 Fremont Property Land Information *	28
Table 6.1 2003 Ranking of Geophysical and Geochemical Anomalies	38
Table 6.2 Line-by-Line Geophysical and Geochemical Anomalies Evaluated in 2003.....	39
Table 6.3 Pine Tree-Josephine 1984 Geological Reserve Estimate	49
Table 6.4 Pine Tree-Josephine 1986 Historical Geological Reserves	49
Table 6.5 Pine Tree-Josephine 1986 Historical “Geological and Mineable Reserves”	50
Table 6.6 Pine Tree-Josephine Historical “Mineral Resource Estimate”	50
Table 6.7 Pine Tree-Josephine Historical Reserves 1988 and 1989	51
Table 6.8 Pine Tree-Josephine Historical Underground Geological (In Situ) Reserves December 1988.....	52
Table 6.9 Pine Tree-Josephine Historical Underground Mining Reserves December 1988	52
Table 6.10 Pine Tree Tailings Resources - October 2008	53
Table 6.11 Queen Specimen Historical “Mining Reserves”	53
Table 6.12 Pine Tree-Josephine Mineral Resource Estimate - October 31, 2016	54
Table 6.13 Pine Tree-Josephine Mineral Resource Estimate - August 31, 2021	55
Table 6.14 Pine Tree-Josephine Historical Gold Production*	56
Table 9.1 Specimen Trench Locations, Orientations and Lengths	82
Table 9.2 Drill Road Channel Sampling Assays >0.5 g/t Au	86
Table 9.3 Fremont Exploration Targets	88
Table 10.1 Summary of Fremont Property Historical and Recent Drilling	93
Table 10.2 Summary of Goldenbell 1985-1986 Drilling	94
Table 10.3 California Gold Drilling 2013-2018	96
Table 10.4 Pine Tree-Josephine Phase I (2013) Drilling Highlights	99
Table 10.5 Pine Tree-Josephine Phase II (2014) Drilling Results	102
Table 10.6 Pine Tree-Josephine Phase III (2015-16) Drilling Results (6 Pages)	105
Table 10.7 Queen Specimen 2016 Drilling Highlights.....	115
Table 10.8 Queen Specimen 2017-2018 Drilling Assay Highlights (3 Pages).....	119
Table 12.1 2013 California Gold Twin Holes	140
Table 13.1 Historical Production Summary.....	141
Table 13.2 Pre-2014 Mineralized Zones for Metallurgical Test Work	142
Table 13.3 Metallurgical Test Reports.....	142
Table 13.4 1986 Gravity Concentration Results.....	144
Table 13.5 May 1986 Metallurgical Test Work Results.....	145
Table 13.6 Utah International Pilot Plant Flotation Concentrate.....	145
Table 13.7 Metallurgical Test Work Laboratories and Processes	146
Table 13.8 Summary of Precious Metal Extraction in Percent.....	147
Table 13.9 Most Effective Metallurgical Treatments	148
Table 13.10 Bacon, Donaldson and Associates Bond Index Test Results.....	148

Table 13.11 Bacon, Donaldson and Associate January / February 1986 Test Work Results....	150
Table 13.12 Utah International May 1986 Test Work Results	150
Table 13.13 Utah International July 1986 Metallurgical Test work Results	150
Table 13.14 Bacon, Donaldson and Associates August 1986 Test Work Results.....	151
Table 13.15 Witteck Development September 1986 Test Work Results	151
Table 13.16 June/July 1987 Test Work Flotation Times	152
Table 13.17 Gold Loss During Carbon Flotation	154
Table 13.18 Cyanidation of Centrifuged Flotation Concentrate.....	154
Table 13.19 Witteck Composite Concentrate Sample Assay	155
Table 13.20 Roasting Test Results – Hazen Research.....	156
Table 13.21 Calcine Cyanidation Reagent Consumption and Results by Laboratory.....	157
Table 13.22 Bacon, Donaldson and Associates Calcine Cyanidation Results	157
Table 13.23 Bulk Flotation Results	160
Table 13.24 Bioleaching Results	161
Table 13.25 Oxide Material Coarse Bottle Roll Leach Test Results.....	161
Table 13.26 Column Test Conditions	162
Table 13.27 Oxide Material Column Leach Test Results.....	162
Table 13.28 Head Analysis.....	165
Table 13.29 Ball Mill Bond Work Index	165
Table 13.30 Rougher Flotation Kinetics Versus Grind Size.....	166
Table 13.31 Cleaner Circuit Flotation Metallurgy.....	168
Table 13.32 Gravity Separation Concentrate Production	169
Table 13.33 Combined Gravity Separation and Flotation Test Results.....	169
Table 13.34 SRM and QTZ Direct Cyanidation Results	170
Table 13.35 SRM and QTZ CIL Results	171
Table 13.36 Metallurgical Processes and Estimated Recoveries.....	172
Table 14.1 Database Summary	175
Table 14.2 Economic Parameters	179
Table 14.3 Grade Estimation Domain Rock Codes	181
Table 14.4 Summary Statistics for Constrained Au Assays (g/t)	182
Table 14.5 Grade Estimation Domain Composite Au Summary Statistics (g/t)	184
Table 14.6 Composite Capping Thresholds.....	189
Table 14.7 Semi-Variograms	190
Table 14.8 Block Model Setup	191
Table 14.9 Summary of Mineral Resource Estimate ⁽¹⁻¹²⁾	195
Table 14.10 Oxide Mineral Resource Estimate Sensitivity	196
Table 14.11 Sulphide Mineral Resource Estimate Sensitivity.....	197
Table 14.12 Grade Block Model Check	198
Table 16.1 Pit Optimization Parameters	202
Table 16.2 Pit Design Parameters	205
Table 16.3 Pine Tree-Josephine Pit Diluted and Undiluted Tonnages	208
Table 16.4 Total Pit Tonnages (Diluted)	209
Table 16.5 Mineralized Material Plant Feed Classification.....	209
Table 16.6 Open Pit Mining Schedule.....	211
Table 16.7 Open Pit Equipment Fleet.....	212
Table 16.8 Open Pit Personnel.....	213
Table 16.9 Waste Rock Balance	215
Table 16.10 Initial Cut-off Grade Parameters.....	223

Table 16.11 Lateral Development.....	226
Table 16.12 Vertical Development.....	226
Table 16.13 Underground Fleet.....	235
Table 16.14 Underground Personnel.....	236
Table 16.15 Underground Mine Plan.....	236
Table 16.16 Underground Development Schedule.....	238
Table 16.17 Underground Production Schedule.....	240
Table 16.18 Combined Mining Schedule (Life of Mine).....	247
Table 17.1 Flotation Concentrator Design Criteria Summary.....	252
Table 17.2 Heap Leach Design Criteria Summary.....	256
Table 17.3 Precipitation and Evaporation in mm.....	260
Table 18.1 Process Plant Power Requirements.....	265
Table 18.2 Heap Leach Power Requirements.....	266
Table 20.1 Primary Land Use Entitlements and Project Approvals.....	270
Table 20.2 Identified Environmental Evaluations Potentially Required for Fremont Project Environmental and Permitting Review Process.....	271
Table 20.3 Primary Environmental Resource Permits and Project Approvals.....	272
Table 20.4 Local, State and Federal Permits and Approvals.....	273
Table 21.1 Project CAPEX Summary.....	279
Table 21.2 Summary of Process Capital Cost / Process Plant Pre-Production Capital Costs by Discipline.....	281
Table 21.3 Process Mobile Equipment.....	283
Table 21.4 Process Plant and Infrastructure Contingency.....	284
Table 21.5 Summary of Process Plant Capital Cost by Discipline.....	286
Table 21.6 Heap Leach Process and Infrastructure Contingency.....	288
Table 21.7 Sustaining Underground Capital Development CAPEX.....	290
Table 21.8 Underground Mobile Fleet and Railveyor™ CAPEX.....	290
Table 21.9 Underground Infrastructure CAPEX.....	291
Table 21.10 Project OPEX Summary.....	292
Table 21.11 Open Pit Mining OPEX.....	292
Table 21.12 Underground Mining OPEX.....	293
Table 21.13 Average Process Plant Operating Cost.....	294
Table 21.14 Process Personnel and Cost Summary.....	297
Table 21.15 Process Plant Power Demand.....	297
Table 21.16 Average Heap Leach Processing Operating Cost.....	299
Table 21.17 Heap Leach Process Personnel and Cost Summary.....	301
Table 21.18 Heap Leach Power Demand.....	301
Table 22.1 Simplified Financial Model.....	306
Table 22.2 Payback Period, NPV and IRR for Baseline Financial Model.....	307
Table 22.3 Project Sensitivity to Discount Rate.....	307
Table 26.1 Recommended Work Program and Budget.....	321

LIST OF FIGURES

Figure 1.1	Project NPV Sensitivity to Gold Price	13
Figure 4.1	Fremont Property Location.....	27
Figure 4.2	Fremont Property Map	29
Figure 5.1	Fremont Property Access	31
Figure 5.2	Fremont Property Infrastructure	33
Figure 5.3	Fremont Property Physiography.....	34
Figure 6.1	Gold Deposits on the Fremont Property	35
Figure 6.2	Pine Tree-Josephine Deposit 1985-1986 RC Drill Hole Locations	43
Figure 6.3	Queen Specimen Deposit 1985-1986 RC Drill Hole Locations.....	44
Figure 6.4	Precision 2008 Drill Hole and Trench Locations	45
Figure 6.5	Mineralized Targets Recognized During the 2014 Surface Mapping and Sampling Program	47
Figure 7.1	Geological Setting of the Fremont Property.....	60
Figure 7.2	Gold Districts of the Sierra Foothills Metamorphic Belt, California	61
Figure 7.3	Fremont Property Geology	64
Figure 7.4	Magnetic Calculated Vertical Derivative Map from the 2015 Airborne Geophysical Survey	66
Figure 7.5	SRK Structural Interpretation of Magnetic First Vertical Derivative	67
Figure 7.6	SRK Map Illustrating Dilational Jog and Folding Interpretation at Queen Specimen Deposit Area	68
Figure 7.7	SRK Structural and Lithology Interpretation	69
Figure 7.8	Mineralized Zone Areas	70
Figure 7.9	Representative Interpretive Vertical Cross Section of the Pine Tree-Josephine Gold Deposit.....	72
Figure 7.10	Visible Gold in Queen Specimen 2018 Drill Hole QS-DD-18-014	73
Figure 7.11	Pine Tree-Josephine Gold Mineralized Trend.....	75
Figure 7.12	Crown Point Prospect Shear Zone.....	76
Figure 8.1	Geodynamic Setting of Orogenic Gold Mineralization.....	77
Figure 8.2	Tectonic Environment of Orogenic Gold Mineralization in California	78
Figure 8.3	Fault-Control Model for Orogenic Gold Mineralization.....	79
Figure 9.1	Fremont Property Gold in Soil Anomalies	81
Figure 9.2	Surface Trenches at Queen Specimen	83
Figure 9.3	Location of Pine Tree-Josephine Drill Road Samples with >0.5 g/t Au	85
Figure 9.4	Fremont Property LiDAR TM Survey Coverage	87
Figure 9.5	Fremont Exploration Targets.....	89
Figure 9.6	Pine Tree-Josephine Extension Exploration Target	90
Figure 9.7	Queen Specimen Extension Exploration Target.....	91
Figure 9.8	Chicken Gulch Exploration Target.....	92
Figure 9.9	Crown Point Exploration Target	92
Figure 10.1	Fremont Property Drill Targets 2013 to 2018, Plan View	95
Figure 10.2	Phase I (2013) Diamond Drill Holes, Plan View	97
Figure 10.3	Vertical Cross-Sectional Projection 20,000 m N	98
Figure 10.4	Pine Tree-Josephine Deposit Phase II Diamond Drilling 2015, Plan View.....	100
Figure 10.5	Vertical Cross-Sectional Projection 22,000 m N	101
Figure 10.6	Pine Tree-Josephine Area Phase III Drilling (2015-2016) Plan View	103

Figure 10.7	Pine Tree-Josephine Phase III Interpreted Vertical Cross-Sectional Projection 21,975 N	104
Figure 10.8	2016 Drill Program Holes Completed in Queen Specimen Area, Plan View ..	112
Figure 10.9	Queen Specimen 2016 Geological Vertical Cross-Sectional Projection 26,700 N	113
Figure 10.10	Queen Specimen 2016 Geological Vertical Cross-Sectional Projection 26,400 N	114
Figure 10.11	2018 Drill Program Holes in Queen Specimen Area, Plan View.....	116
Figure 10.12	Queen Specimen 2018 Vertical Cross Section Projections 26,000 N and 26,100 N	117
Figure 10.13	Queen Specimen 2018 Vertical Cross-Sectional Projections 26,200 N and 26,400 N	118
Figure 11.1	California Gold Specific Gravity Verification at ALS.....	125
Figure 11.2	Performance of MEG-Au.13.02 CRM for Au.....	127
Figure 11.3	Performance of MEG-Au.11.17 CRM for Au.....	127
Figure 11.4	Performance of MEG-S107006X CRM for Au.....	128
Figure 11.5	Performance of MEG-LWA-25 CRM for Au	128
Figure 11.6	Performance of MEG-Au.11.34 CRM for Au.....	129
Figure 11.7	Performance of Blank for Au	130
Figure 11.8	Performance of Lab Duplicates for Au	131
Figure 11.9	Performance of Oreas 231 CRM for Au.....	132
Figure 11.10	Performance of Oreas 233 CRM for Au.....	132
Figure 11.11	Performance of Oreas 236 CRM for Au.....	133
Figure 11.12	Performance of Blank for Au	134
Figure 11.13	Performance of Field Duplicates for Au R ² values	135
Figure 11.14	Performance of Lab Duplicates for Au	135
Figure 11.15	Performance of Lab Duplicates for Au 2013-2016	136
Figure 12.1	Authors Site Visit Results for Au.....	139
Figure 13.1	Oxide Material Column Leach Test Results	163
Figure 13.2	Rougher Flotation Kinetic Relationships	167
Figure 13.3	OXC Coarse Bottle Roll Leach Kinetics.....	170
Figure 14.1	Surface Drilling and Trenching	174
Figure 14.2	Surface Trench QS-TR-22-01NW.....	176
Figure 14.3	Historical Assay Level Plan with Assays.....	177
Figure 14.4	Underground Development and Sampling.....	178
Figure 14.5	Grade Estimation Domains.....	181
Figure 14.6	Twin Drill Holes Analysis.....	183
Figure 14.7	QQ Plots	186
Figure 14.8	Mineral Resources and Pit Limits	194
Figure 14.9	Swath Plot.....	198
Figure 16.1	Pit Optimization Result: NPV Versus Revenue Factor	204
Figure 16.2	Pine Tree-Josephine Pit Design.....	206
Figure 16.3	Queen Specimen Pit Design	207
Figure 16.4	Underground Mine Extents	217
Figure 16.5	Railveyor TM Route	218
Figure 16.6	Mining Blocks and Stope Grades	219
Figure 16.7	Railveyor TM Cross-Section	222
Figure 16.8	Railveyor TM Loop Configuration.....	222

Figure 16.9	Underground Development Schematic.....	225
Figure 16.10	Longitudinal Projection of Material Handling System	229
Figure 16.11	Ventilation and Pastefill Distribution Systems.....	231
Figure 16.12	Electrical Distribution and Dewatering System	232
Figure 16.13	Underground Infrastructure	233
Figure 16.14	Historical and Planned Underground Workings.....	241
Figure 16.15	Underground Workings as of Year 2.....	242
Figure 16.16	Underground Workings as of Year 4.....	243
Figure 16.17	Underground Workings as of Year 8.....	244
Figure 16.18	Underground Workings at End of Life.....	245
Figure 17.1	Process Plant Area General Arrangement	249
Figure 17.2	Flotation Concentrator Flowsheet 1	250
Figure 17.3	Flotation Concentrator Flowsheet 2	251
Figure 17.4	Heap Leach Flowsheet	255
Figure 17.5	Water Balance	261
Figure 18.1	Fremont Project Site Layout.....	263
Figure 22.1	Project Post-Tax NPV Sensitivity	308
Figure 22.2	Project Post-Tax IRR Sensitivity.....	308

1.0 SUMMARY

This report was prepared to provide a National Instrument (“NI”) 43-101 Technical Report (the “Report”) and Preliminary Economic Assessment (“PEA”) for the gold mineralization contained on the Fremont Property (the “Property” or the “Fremont Gold Property”) in Mariposa County, central California, USA. The Property is owned 100% by Fremont Gold Mining LLC., a wholly owned subsidiary of Stratabound Minerals Corp. (“Stratabound” or the “Company”). The Fremont Gold Property is located 241 km east of the City of San Francisco, in the western foothills of the Sierra Nevada Mountains. This location coincides with the southernmost portion of the prolific California Mother Lode Gold Belt. The centre of the Property is at approximately 754,360 m E and 4,164,460 m N (NAD83 UTM Zone 10N), or Longitude 120° 07’ W and Latitude 37° 36’ N.

This PEA has been prepared by P&E Mining Consultants Inc. of Brampton, Ontario, Canada. Sections of the Report on metallurgical testing, process plant and heap leach design and costing, and site infrastructure have been prepared by Kappes, Cassidy & Associates of Reno, Nevada, USA.

1.1 PROPERTY DESCRIPTION, LOCATION, ACCESS AND PHYSIOGRAPHY

The Fremont Gold Property consists of three Assessor Parcel Numbers (“APNs”) totalling 3,351.22 acres (1,357 ha). The three APNs include mineral and surface rights and the land under State Highway 49 and are subject to a 3% NSR royalty. The Property covers eight full and partial sections, described as: Sections 4, 5, 8, 9, 10, 15, 16, and 17, Township 4 South, Range 17 East, Mount Diablo Base and Meridian.

The Fremont Property is readily accessible by California State Highway 49, which bisects the Property from north to south. A 70 kV power transmission line owned by Pacific Gas and Electric crosses the Property from east to west. The local Bear Valley substation is located adjacent to Fremont Gold Mining LLC’s office-warehouse, along Highway 49.

The Property is located mid-way between the Towns of Mariposa and Coulterville. The Town of Mariposa (population 1,186; 2019 Census) is located 20.3 km south of the Property and is the nearest community with major infrastructure and where the county seat is located for Mariposa County. The nearest urban centre is the City of Merced, located 37 miles to the west-southwest of the Property. Merced is the county seat for Merced County (population 82,662; 2019 Census) and the location of the nearest railhead.

The climate is characterized by hot, dry summers with the highest average temperature of approximately 32°C in July and cool, wet winters, with the lowest average temperature of approximately 1°C in December and January (www.weatherspark.com). Exploration programs can be carried out year-round on the Property.

Most of the Property area lies south and adjacent to the Merced River Valley. Elevations range from 274 masl along the Merced River to >1,036 masl in the southeast corner of the Property. Vegetation on the Property consists of scattered clumps of scrub oak with open grasslands in the

southeast part of the Property and manzanita and chaparral covering steep gullies over the remainder of the Property. Pine trees occur as isolated trees or in clumps and grow well on reclaimed waste rock dump sites.

1.2 HISTORY

Mining at Pine Tree, Josephine and Queen Specimen Deposits commenced in the early 1850s. The Pine Tree and Josephine Mines operated almost continuously until the early 1870s. Intermittent mining was carried out until 1944, and the total historical production is reported to be approximately 540,400 tonnes for a total of 126,223 ounces of gold.

The more recent exploration on the Property commenced in 1984 when the Property was acquired by Goldenbell Mining Corporation (“Goldenbell”). Goldenbell compiled the historical data and completed geophysical surveys, drilling, and underground bulk sampling. In 1985-1986, Goldenbell completed a 140 reverse circulation (“RC”) drill hole program totalling 19,860 m (65,158 ft) and also drilled 1,196 m (3,925 ft) of rotary (18 drill holes) and 1,009 m (3,310 ft) of core drill holes (16 drill holes). Four targets were drilled, namely Pine Tree-Josephine, Queen Specimen-Succedo, Chicken Gulch, and Crown Point. A Feasibility Study and a draft Environmental Impact Report (“EIR”) towards permitting were prepared based on an open pit operation with processing in a roaster-acid plant facility. A heap leach option was also investigated. In the late 1980s, Northwest Gold Corp. acquired the Property and completed metallurgical test work and detailed planning studies which indicated that capital costs would be significantly higher than originally anticipated and, based on the prevailing gold price, the Property was deemed uneconomic.

In 2008 and 2009, Global Mining Explorations Ventures LLC (later Precision Gold LLC; “Precision”) completed a drilling program on the historical tailings at the Pine Tree Mine and estimated a Mineral Resource. However, Precision relinquished its option to the Property in 2009 and no further exploration was completed until 2013 when California Gold Mining Inc. (“California Gold”) acquired the Property. California Gold completed exploration and drilling programs, primarily at the Pine Tree-Josephine and Queen Specimen Deposits, between 2013 and 2018. California Gold was acquired by Stratabound in 2021.

1.3 GEOLOGY, MINERALIZATION, AND DEPOSIT TYPE

The Fremont Property is located in the Mother Lode Gold Belt District, which occurs in the southern portion of the western Sierra Nevada Foothills Metamorphic Belt. The Mother Lode Gold Belt District occurs along the Melones Fault Zone, a major, crustal-scale fault trending north-northwesterly for 200 km. During the Early Cretaceous period, the Melones reverse fault system was reactivated in a transpressive regime, resulting in gold mineralization at approximately 125 ± 10 Ma.

The Property is located at the southern tip of the Mother Lode Gold Belt. The geology of the Property is dominated by the Mariposa Formation metasedimentary and metavolcanic rocks to the west, the Melones Fault Zone in the centre, and the Bullion Mountain Formation metavolcanics and Briceburg Formation metasedimentary rocks and metavolcanics to the east. The Melones Fault Zone hosts the historical Pine Tree-Josephine Gold Deposit and the Queen Specimen Deposit, one

km to the north. The Pine Tree-Josephine Deposit was mined from the 1850s to the 1940s via numerous shafts and underground drifts and produced approximately 125,000 ounces of gold, primarily by shrinkage and open stoping mining methods.

Three main styles of gold mineralization are present at the Pine Tree-Josephine Deposit and generally throughout the four km mineralized trend on the Fremont Property: 1) quartz hosted; 2) sulphide replacement; and 3) oxide cap mineralization. The quartz-hosted mineralization, represented primarily by the footwall and hanging wall veins and stockwork vein arrays locally in the footwall and hanging wall, mainly consists of free gold in quartz. During historical mining, higher gold grades were found in large quartz veins that were cut by late-stage quartz veins, defining mineralized shoots. The mineralized shoots were generally short in strike length but persistent at depth.

The sulphide-replacement mineralization occurs mainly in the tectonic melange between the footwall and hanging wall quartz veins. The host meta-sedimentary, volcanic and ultramafic rocks are intensely altered to ankerite, sericite, albite, quartz, mariposite, and 3 to 4% pyrite ± arsenopyrite ± chalcopyrite. Gold occurs intergrown with pyrite and interstitial to quartz. Mineralized schists and tectonite pods contain pyrite and ankerite and host quartz-ankerite veinlets.

The oxide-gold mineralization occurs as a thin cap on the upper portions of the gold deposits. In the order of one-sixth to one-seventh of the upper portions of the deposits are variably oxidized and potentially amenable to cyanide heap leaching. Generally, the oxide zone varies from approximately one metre to a maximum of 56 m below surface.

The gold deposits on the Fremont Property are hosted in metamorphosed volcanic and sedimentary rocks and associated with a major fault zone. They are therefore classified as orogenic mesothermal gold deposits.

1.4 EXPLORATION

Stratabound completed surface exploration activities in 2022, which included compilation and reporting of a 2016-2017 property-wide soil geochemistry survey, trenching, mine development activities and flying a LiDAR™ topographic survey.

The soil geochemistry survey covered the entire Fremont Property with 1,364 samples. The survey was completed by California Gold between 2016-2017, however, the results were not previously compiled and reported. Based on their recent compilation, Stratabound reported a large gold-in-soil anomaly extending across the entire four km Property length and averaging 285 m wide. The property-wide soil geochemical survey defines nearly continuous gold-in-soil mineralization of >30 ppb up to 112,491 ppb gold (112.5 g/t Au), covering an area of 1.14 km² or 282 acres. The surface gold-in-soil anomaly encompasses and links the three historical producing gold Deposits: the Pine Tree, Josephine and Queen Specimen Mines, plus the undeveloped Chicken Gulch and Crown Point Zones.

The exploration work completed includes excavation of 10 surface trenches at 50 m intervals across 500 m of strike length overlying the Queen Specimen Deposit. This Deposit is the northernmost of four separately drilled gold-mineralized zones that are connected along four km

of strike on surface by the >30 ppb gold in-soil anomaly. Systematic sampling of the new Queen Specimen trenches was designed to define the at-surface gold mineralization projected from historical and recent drill holes extending below 300 m from surface.

In addition to the current Mineral Resources, four Exploration Targets have been established for the Fremont Property, with the following potential characteristics: 1) Pine Tree-Josephine Extension at a range of 21 to 29 Mt and a grade range of 1.80 to 2.00 g/t Au; 2) Queen Specimen Extension at a range of 1 to 2 Mt and a grade range of 1.10 to 1.30 g/t Au; 3) Chicken Gulch at a range of 29 to 40 Mt and a grade range of 0.40 to 0.70 g/t Au; and 4) Crown Point at a range of 1 to 2 Mt and a grade range of 0.30 to 0.60 g/t Au.

The Exploration Targets are based on the estimated strike length, depth and thickness of the known mineralization, which is supported by sparse drill holes and observations of mineralized surface exposures. The potential quantities and grades of the Exploration Targets are conceptual in nature. There has been insufficient work done by a Qualified Person to define these Exploration Target estimates as Mineral Resources. The Company is not treating these estimates as Mineral Resources, and readers should not place undue reliance on these estimates. Even with additional work, there is no certainty that these estimates will be classified as Mineral Resources. In addition, there is no certainty that these Exploration Targets will ever prove to be economically recoverable.

1.5 DRILLING

The most recent exploration drilling programs on the Fremont Property were completed by California Gold between 2013 and 2018. California Gold completed 82 surface diamond drill holes totalling 19,781 m. Of the 82 drill holes, 52 were completed at Pine Tree-Josephine, 26 at Queen Specimen, and four in the historical French Mine area. The 2013 to 2016 results from the Pine Tree-Josephine Deposit area drilling, along with the historical 1985-1986 drilling results (113 drill holes totalling 16,340 m), were previously incorporated into the 2016 initial Mineral Resource Estimate released by California Gold and the 2021 updated Mineral Resource Estimate released by Stratabound.

1.6 SAMPLE PREPARATION, ANALYSES, SECURITY AND VERIFICATION

In the opinion of the authors (the “Authors”) of this Technical Report, the sample preparation, security and analytical procedures for the Fremont Gold Project drilling and trench sampling programs were adequate. Examination of QA/QC results for all recent sampling indicates no significant issues with accuracy, contamination or precision in the data, and umpire sampling has confirmed the tenor of the original assay data. Independent due diligence sampling by the Authors shows acceptable correlation with the original assays. It is the opinion of the Authors that the data are suitable for use in the current Mineral Resource Estimate.

1.7 MINERAL PROCESSING AND METALLURGICAL TESTING

The historical operations consistently achieved gold recoveries averaging 88.5% with a combined gravity and flotation circuit. The locked-cycle test results of 1986 show a flotation recovery of

91.3% on a composite sample of Zones 5, 6 and 7. In June/July 1987, Beacon Hill achieved a flotation gold recovery of 89.7% on the composite underground bulk sample.

Within the 2014 iteration of test work, the samples were grouped by different metallurgical domains, including sulphide replacement material (“SRM”) and quartz (“QTZ”), for treatment by gravity and flotation. The 2014 combined gravity and flotation recovery for the SRM was 85.6% for gold and 69.1% for silver. The 2014 combined gravity and flotation recovery for the QTZ domain was 93.6% for gold and 75.6% for silver.

The flotation concentrate was not amenable to cyanidation without further processing. The roasting process was the most effective oxidation process tested for the recovery of gold. Roasting tests were not conducted on the SRM and QTZ domain samples. However, there has been extensive roasting test work completed with cyanide leaching of the roasted product (calcine). The tests at scoping level achieved 92.7% gold recovery, and in the pilot campaign at the Lurgi Plant in Frankfurt, Germany, achieved 90% gold recovery in cyanidation of the calcine.

The coarse bottle roll on the oxide (“OXC”) domain achieved a gold recovery of 93% in ten days of leaching minus 25.4 mm (1 inch) material, which confirms that the OXC domain has reasonable potential for heap leaching. Since each zone has an oxide cap on the surface, an average laboratory recovery of 82.0% is considered to be a reasonable estimate.

1.8 MINERAL RESOURCE ESTIMATE

The Authors prepared an updated Mineral Resource Estimate for the Pine Tree-Josephine and Queen Specimen gold deposits. The updated Mineral Resource Estimate consists of a total of 1.163 million ounces (“Moz”) Au contained in 19.0 million tonnes (“Mt”) at 1.90 g/t Au as Indicated Mineral Resources and 2.024 Moz contained in 28.3 Mt at 2.22 g/t Au as Inferred Mineral Resources (Table 1.1). The pit-constrained Mineral Resources consist of 1.15 Moz Au in the Indicated classification and 1.49 Moz in the Inferred classification. The out-of-pit (underground) Mineral Resources consist of 9 thousand ounces (“koz”) Au in the Indicated classification and 536 koz Au in the Inferred classification.

TABLE 1.1			
SUMMARY OF MINERAL RESOURCE ESTIMATE ⁽¹⁻¹²⁾			
Classification	Tonnes (k)	Grade (g/t Au)	Ounces (koz Au)
Indicated			
Pit-Constrained	18,891	1.9	1,154
Out-of-Pit	121	2.21	9
Total	19,011	1.9	1,163
Inferred			
Pit-Constrained	22,507	2.06	1,488
Out-of-Pit	5,816	2.87	536
Total	28,323	2.22	2,024

Notes: All dollar (\$) values are stated in United States dollars (US\$).

- 1) Mineral Resources were estimated using the Canadian Institute of Mining, Metallurgy and Petroleum (CIM), CIM Standards on Mineral Resources and Reserves, Definitions (2014) and Best Practices Guidelines (2019) prepared by the CIM Standing Committee on Reserve Definitions and adopted by CIM Council.
- 2) The Inferred Mineral Resource in this estimate has a lower level of confidence that that applied to an Indicated Mineral Resource and must not be converted to a Mineral Reserve. It is reasonably expected that the majority of the Inferred Mineral Resource could be upgraded to an Indicated Mineral Resource with continued exploration.
- 3) Mineral Resources are reported within a constraining conceptual pit shell.
- 4) Inverse distance weighting of capped composite grades within domains was used for grade estimation.
- 5) Composite grade capping was implemented prior to grade estimation.
- 6) Bulk density was assigned by redox domain.
- 7) A gold price of US\$1,700/oz was used.
- 8) A cut-off grade of 0.25 g/t Au for oxide and quartz pit-constrained material and 0.45 g/t Au for sulphide pit-constrained material, and 1.45 g/t Au for out-of-pit (underground) material was used.
- 9) Pit-constrained Mineral Resources were determined to be potentially economic based on a mining cost of \$3/t mined, heap leach processing of \$9.16/t, flotation processing of \$10.02/t and G&A costs of \$2.50/t, with metallurgical recoveries of 85% by heap leach and 90% by flotation.
- 10) Out-of-pit Mineral Resources were determined to be potentially economic with the longhole mining method based on an underground mining cost of \$40/t mined, processing of \$10.02/t and G&A costs of \$2.50/t, with a metallurgical recovery of 90%. Out-of-Pit grade blocks that did not demonstrate potentially mineable configurations were removed from the Mineral Resource Estimate.
- 11) Totals may not sum due to rounding.
- 12) Mineral Resources that are not Mineral Reserves do not have demonstrated economic viability.

The updated Mineral Resource Estimate is based on 33,982 m of drilling, 518 m of trench sampling, and 5,760 m of underground channel sampling. The effective date of the updated Mineral Resource Estimate is February 15, 2023. This updated Mineral Resource Estimate represents a 121% increase in the Indicated Mineral Resource classification and a 348% increase in the Inferred Mineral Classification since Stratabound acquired the Fremont Gold Project.

Pit-constrained Mineral Resources are reported using a cut-off grade of 0.25 g/t Au for oxide material and 0.45 g/t Au for sulphide material. Out-of-Pit (underground) Mineral Resources are reported using a cut-off grade of 1.45 g/t Au. Underground Mineral Resources have been constrained within potentially mineable longhole shapes based on block grade and continuity.

Historical mining has been depleted from the Mineral Resource Estimate by assigning a zero-volume percentage block inclusion for known areas of mining and development. Mineral Resources that are not Mineral Reserves do not have demonstrated economic viability.

The Property is four km along strike from north to south. The Deposits are open along strike and particularly down dip, and further drilling may provide additional Mineral Resources.

1.9 MINING METHODS

The mine designs and schedule utilize Inferred Mineral Resources as part of the analysis. Mineral Resources that are not Mineral Reserves do not have demonstrated economic viability. This PEA is preliminary in nature in that it includes Inferred Mineral Resources that are considered too speculative to have economic considerations applied to them and should not be relied upon for that purpose.

Mining will begin with three small oxide starter pits and heap leach in Year 1 concurrent with initial Pine Tree-Josephine open pit phase 1. The oxide heap leach pad is planned to be constructed within the tailings storage facility to minimize Project footprint and use a common liner.

The three-phased Pine Tree-Josephine open pit is planned for a production rate of 6,000 tpd to provide low-cost production and generate early cash flow while the construction and development of the underground operation starts in Year 2.

Upon completion of the Pine Tree-Josephine open pit in Year 4, the Queen Specimen open pit is planned to be developed to supplement underground production to feed the process plant at a rate of 750 ktpa. The open pits will be backfilled with waste rock after mining is completed. There will be opportunity for progressive reclamation over the life of the mine.

The Pine Tree-Josephine underground mine is planned for a production rate of 4,000 tpd. The selected mining method is longhole open stoping with both longitudinal retreat and transverse mining, depending on the vein thickness. Stopes will be filled with cemented paste backfill. Stope dimensions will average 10 m in strike length and 30 m in height, with a minimum thickness of 4 m. Mineralized material will be extracted using a fleet of 10-tonne load-haul-dump units that will tip mineralized material down a broken material pass to a Railveyor™ system on a main haulage level. The Railveyor™ will transport the mineralized material to the process plant via the portal and up a surface hillside.

The underground mine will have its own ventilation, electrical, and dewatering systems. Fresh air will be provided by one or more ventilation raises and will exhaust via the ramp. Dewatering pump stations will use electric submersible and centrifugal pumps to move water to surface via boreholes or piping in the vent raises. Electrical power will be provided initially to the underground mine in the ramp from transformers located near the portals, and eventually by power lines run down the vent raises or through boreholes.

Both open pit and underground development and mining will be performed by Company personnel, with a leased fleet.

1.10 RECOVERY METHODS

A total of 6,000 tpd of mineralized material will be treated in a process plant that consists of three-stage crushing, followed by a grinding circuit consisting of a ball mill. A gravity circuit will recover coarse gold from the plant feed, which subsequently moves on to rougher flotation cells creating a sulphide concentrate containing the gold. The concentrate will be reground and fed to cleaner cells where the clean concentrate and gravity concentrate will be filtered and bagged for shipping to a roaster offsite.

For the first year of operation, a heap leach plant will be built to recover the gold in carbon from the heap leach pad that will be constructed in the tailings storage facility to minimize footprint and maximize use of liner construction.

The process plant is followed by a tailings filtration plant with a filter press to produce paste backfill to send underground and/or to produce dry stack tailings for surface storage.

The combined gravity and flotation gold recovery for the SRM is 85.6% and for the QTZ is 93.6%. At the roaster, 82% of the gold contained in concentrate is estimated to be payable, including processing charges. The heap leach recovery for the OXC material is expected to be 82%.

1.11 PROJECT INFRASTRUCTURE

The Property is serviced by paved, all-weather Highway 49 which bisects the Property, secondary access roads, and PG&E power line and transformer station on site. An office/drill core logging facility is also on site. Site infrastructure will include an administration office building, change house facility, 6,000 tpd processing plant, pastefill/tailings filtration plant, filtered tailings management facility, laboratory and surface workshop. The underground mine will include two portals and a Railveyor™. There will be no camp, and employees will be expected to travel from nearby communities. Water for the Project is assumed to be obtained from dewatering of historical underground workings and voids and wells.

1.12 MARKET STUDIES AND CONTRACTS

There are currently no material contracts in place pertaining to the Fremont Gold Project. The Project is open to the spot gold price market and there are no streaming or forward sales contracts in place. The Authors of this Technical Report used an approximate 3-year average monthly trailing gold price as of September 30, 2022 of US\$1,750/oz for this PEA.

1.13 ENVIRONMENTAL STUDIES, PERMITS AND SOCIAL OR COMMUNITY IMPACT

The Project is located on private land within the boundaries of the County of Mariposa in the state of California. Mariposa County is the lead agent for all county, state and federal permitting jurisdictions.

Exploration permits are issued by Mariposa County through an Administrative Use Permit (“AUP”) valid for a three-year period. A permit issued on October 2, 2017 was extended to April 2, 2022. Stratabound resumed and concluded the AUP exploration work in March 2022, reclaimed the surface disturbance and received notice from the Mariposa County Planning Department that the AUP was successfully closed out on June 28, 2022. Depending upon the County Planning Departments review of proposed scope of any future exploration work an AUP, Conditional Use Permit (“CUP”) or Surface Mining and Reclamation Act (“SMARA”) permit may be applicable. The Project is subject to the California Environmental Quality Assurance (“CEQA”) process. A CUP and approved closure plan with associated financial assurance will be sought from the County following the completion of the Environmental Impact Report and Closure Plan acceptance. In addition to CUP and closure plan approval, the Project will require permits and authorizations prior to construction and operation of the mine. Site development and operating permits and approvals are those site-specific approvals required either prior to construction or operation and are typically issued by local, state, or federal agencies through an administrative process typical in the mining industry. Additionally, a county administered Grading Permit may be necessary where access roads are required.

In 2022, Stratabound initiated environmental baseline studies, including biological mapping of flora and fauna. Surface and groundwater sampling points, used in previous studies, have been upgraded and routine sampling initiated. Mine water, present in underground mine openings, is being sampled and analyzed.

The mine closure cost is currently estimated at \$30M.

Fremont Gold has and will continue to engage and consult with public, county, state and federal agency stakeholders, regarding the Project, along with First Nations Tribes of the State of California.

The Authors are not aware of any environmental liabilities on the Property. The Authors are not aware of any other significant factors and risks that may affect access, title, or the right or ability to perform the proposed work program on the Property.

1.14 CAPITAL AND OPERATING COSTS

Costs in this PEA are reported as Q4 2022 US dollars (\$) with no provision for escalation. Capital costs (“CAPEX”) include 15% contingency, and operating costs (“OPEX”) do not include a contingency.

1.14.1 Capital Costs

Initial CAPEX is estimated at \$203M (Table 1.2). The majority of initial capital costs will be for the process plant, tailings facility and tailings filtration plant. Infrastructure costs consist of site buildings and a highway bypass to allow for open pit mining. Sustaining CAPEX is estimated at \$283M over 11 production years and is primarily for underground mine development, a Railveyor™ system, and mining equipment. Total CAPEX over the life-of-mine (“LOM”) is estimated at \$486M, which is equivalent to \$21.75/t processed.

**TABLE 1.2
PROJECT CAPEX SUMMARY**

Area	Initial Capital Costs (\$M)	Sustaining Capital Costs (\$M)	Total Capital Costs (\$M)
Open Pit Pre-stripping, Heap Leach	7.9	8.0	15.9
Open Pit Mining Equipment	13.4	36.0	49.4
Site Infrastructure & Hwy 49 Re-alignment	30.1	9.9	40.0
Process Plant	72.8	0.0	72.8
Tails, Filtration, Stacking	38.5	2.5	41.0
Underground Development, Pastefill Plant	5.6	166.6	172.2
Railveyor™	0.0	22.8	22.8
Owners Cost	8.2	0.0	8.2
Subtotal	176.5	245.9	422.5
Contingency @ 15%	26.5	36.9	63.4
Total¹	203.0	282.8	485.8

Notes: All dollar (\$) values are stated in United States dollars (US\$).

1 Totals may not sum due to rounding.

2 Open pit and underground mining equipment is leased.

3 Contingency is applied to capitalized operating costs.

1.14.2 Operating Costs

OPEX is estimated to total \$1,163M over the LOM, at an average unit cost of \$52.05/t processed (Table 1.3). Development and mining will be performed entirely by Company personnel, with an equipment fleet which will be leased over five-year terms. Processing will be performed on site, with tailings used as paste backfill for the underground. A contractor will be engaged to transport sulphide concentrate to a toll roasting plant.

TABLE 1.3 PROJECT OPEX SUMMARY		
Area	LOM Total Operating Costs (\$M)	LOM Unit Cost per Tonne (\$/t)
Open Pit Mining	173.3	16.62
Underground Mining	531.8	46.69
Heap Leach Processing	3.6	7.07
Flotation Processing ²	255.3	11.70
Concentrate Transport ³	141.4	6.48
G&A	57.0	2.55
Total¹	1,162.5	52.05

Notes: All dollar (\$) values are stated in United States dollars (US\$).

1 Totals may not sum due to rounding.

2 Includes operating costs associated with tailings re-handling, transport, storage and re-slurrying.

3 Includes concentrate transport to the toll roaster facility.

1.14.3 Other Costs

The Project is subject to a 3% NSR royalty and the total royalty cost over the LOM is estimated at \$68.4M.

Closure costs at the end of mine life are estimated at \$30M to backfill the open pits, seal the portals and includes severance costs for employees.

Cash costs over the LOM, including royalties, are estimated to average \$924/oz. All-In Sustaining Costs (“AISC”) over the LOM are estimated to average \$1,162/oz and include closure costs.

1.15 ECONOMIC ANALYSIS

The open pit mining schedule includes a rapid ramp-up of production in Year -1, starting at 40% capacity and reaching full capacity in the following year. The ramp-up period of the process plant has been assumed to average 85% for Year 1 with Q1 at 60%, Q2 at 80%, Q3 at 90%, and Q4 at 100%.

The mineralized material production rate is set at 2.19 Mtpa, which is assumed to be an average throughput rate of 6,000 tpd over one year of processing.

Table 1.4 presents a summary of the PEA financial results, including the NPV, IRR and payback period of the Project under baseline inputs (5% discount rate, US\$1,750/oz gold price, OPEX and CAPEX as in Tables 1.2 and 1.3 above). Taxes are estimated at 21% for Federal income tax and 8.8% for California State income tax.

TABLE 1.4
PEA FINANCIAL RESULTS

Item	Units	Result	
General			
Gold Price	US\$/oz	1,750	
Life-of-Mine	years	11	
Production			
Total Gold Mine Production	koz	1,727	
Average Annual Gold Production	koz	118	
Total Gold Ounces Recovered	koz	1,303	
Operating Costs			
Open Pit Mining	\$/t mined	2.81	
Underground Mining	\$/t mined	46.69	
Leach Processing	\$/t processed	7.07	
Processing Cost	\$/t processed	11.70	
Concentrate Transport	\$/t processed	6.48	
G&A Cost	\$/t processed	2.55	
Total Operating Costs	\$/t processed	52.05	
Cash Costs	\$/oz Au	924	
AISC	\$/oz Au	1,162	
Capital Costs			
Initial Capital	\$M	203	
Sustaining Capital	\$M	283	
Closure & Severance Costs	\$M	30	
Financials		Pre-Tax	Post-Tax
NPV @ 5%	\$M	328	217
IRR	%	28.6	21.4
Payback	years	3.5	4.2

Note: All dollar (\$) values are stated in United States dollars (US\$).

The Project NPV is sensitive to several factors, with the largest impacts coming from factors affecting revenue from gold production, such as: gold price, process recovery, and payable gold factor (value of gold in concentrate less toll roasting charges). Figure 1.1 presents the gold price, OPEX and CAPEX sensitivity on NPV.

FIGURE 1.1 PROJECT NPV SENSITIVITY TO GOLD PRICE

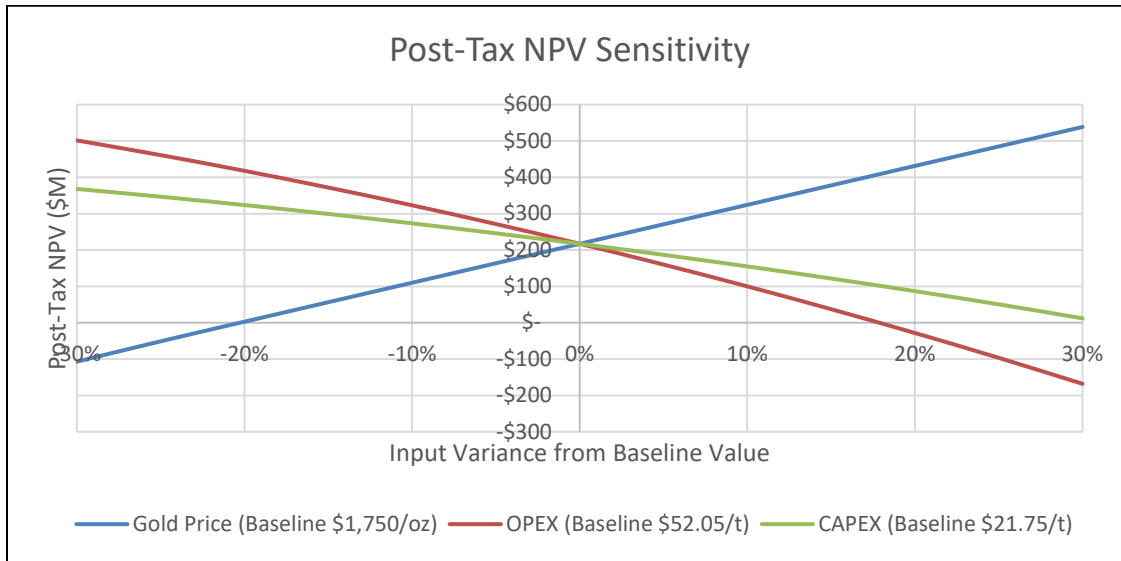

1.16 ADJACENT PROPERTIES

There are no active gold properties adjacent to the Fremont Property. Historical mines Potosi, Malvera, Tyro, Mary Harrison, Virginia, and Red Bank are located approximately 12 km north of the Pine Tree-Josephine Mine. Historical mines Yellowstone, Mt. Gaines, Mt. Ophir and Princeton are located approximately 10 km to the south.

1.17 RISKS AND OPPORTUNITIES

Anticipated risks with the highest potential impact to the Project include the availability of a toll roasting plant, a lack of geotechnical study for the underground mine, and that 83% of the underground mine plan consists of Inferred Mineral Resources.

Opportunities consist of the potential to extend the Deposit along strike and down dip with additional drilling, the potential to delineate further oxide Mineral Resources for heap leaching, and the use of electric equipment for underground mining.

1.18 CONCLUSIONS

The Fremont Gold Project is planned to produce 22.3 Mt of mineralized material at a nominal production rate of 6,000 tpd and an average grade of 2.4 g/t Au over an 11-year mine life. Production from the open pit mine plan will consist of 7.91 Mt of Indicated Mineral Resource at 1.82 g/t Au and 2.55 Mt of Inferred Mineral Resource at 1.31 g/t Au. Production from the underground mine plan will consist of 1.89 Mt of Indicated Mineral Resource at 3.14 g/t Au and 9.51 Mt of Inferred Mineral Resource at 3.12 g/t Au. Total contained gold is estimated at 1,727 koz and the LOM amount of gold recovered after toll roaster processing is estimated at 1,303 koz or an average of 118,000 oz per year.

Cash costs over the LOM, including royalties, are estimated to average \$924/oz. All-In Sustaining Costs (“AISC”) over the LOM are estimated to average \$1,162/oz and include closure costs.

At a 5% discount rate and US\$1,750/oz gold price the post-tax NPV of the Project is estimated at \$217M (\$328M pre-tax), with an IRR of 21.4% (28.6% pre-tax). This results in a payback period of approximately 4.2 years. The Project NPV is most sensitive to factors affecting revenue from gold production, such as: gold price, processing recovery, and gold payable factor (value of gold in concentrate less toll roasting charges).

1.19 RECOMMENDATIONS

The Authors of this Technical Report consider that the Fremont Gold Project contains a significant gold Mineral Resource base that merits further evaluation. This PEA shows potential economic viability for an open pit and underground mining and processing plan, however, much more may still be done that would enhance these economics.

The Authors recommend advancing the Project in a two-phase approach. The first phase of activity would have the objective of building upon the oxide and adjacent near-surface Inferred Mineral Resources for inclusion into an updated Mineral Resource Estimate and a potentially economically improved PEA. Further drilling is also recommended in the first phase to follow up on the continuous, four-kilometre-long gold-in-soil anomaly which is coincident with the two deposits and the additional Crown Point and Chicken Gulch mineralized zones. The second phase would advance the Project to the Pre-Feasibility level of confidence and is not contingent on the success of the first phase. The second phase would include infill drilling to upgrade Inferred Mineral Resources to the Indicated and Measured Mineral Resource classifications, a bulk sample, metallurgical, geotechnical, hydrogeological, permitting, environmental studies and community engagement activities. Drilling in all phases would additionally consider analysis for groundwater and hydrogeological investigations and geotechnical.

A recommended \$22M work program is proposed in Table 1.5.

TABLE 1.5
RECOMMENDED WORK PROGRAM AND BUDGET

Program	Units (m)	Unit Cost (\$/m)	Budget (\$M)
Phase One: Define Near-Surface Inferred Mineral Resource Potential			
Surface Trench Sampling			0.2
RC Drilling Oxide West of Mineral Resource	2,000	150	0.3
RC Drilling Step-out (100 m Sections)	3,300	150	0.5
Step-Out Diamond Drilling – 0.5 km strike	1,500	200	0.3
Mineral Resource and PEA Updates			0.3
Subtotal Phase One			1.6
Phase Two:			
Bulk Sample (100 kt @ \$7/tonne)			0.7
In-fill Diamond Drilling (to Indicated)	20,000	200	4.0
Step-Out and Exploration Diamond Drilling	20,000	200	4.0
Geotechnical and Hydrology Studies			1.0
Metallurgical Test work			0.3
Permitting and Environmental Studies			5.0
Pre-Feasibility Study			2.5
Subtotal Phase Two			17.5
Contingency (15%)			3.0
Total			22.1

2.0 INTRODUCTION AND TERMS OF REFERENCE

2.1 TERMS OF REFERENCE

The following report was prepared by P&E Mining Consultants Inc. (“P&E”) to provide a National Instrument (“NI”) 43-101 Technical Report (the “Report”) and Preliminary Economic Assessment (“PEA”) for the gold mineralization contained in the Pine Tree-Josephine and Queen Specimen Deposits of the Fremont Property (the “Property” or “Fremont Gold Project”), Mariposa County, California, USA. Stratabound Minerals Corp. (“Stratabound” or the “Company”) has 100% ownership of the Property.

P&E was assisted by Kappes, Cassiday & Associates (“KCA”) of Reno, Nevada, USA in the preparation of this PEA on metallurgical testing, process plant and heap leach design and costing, and site infrastructure.

This Report was prepared at the request of Mr. R. Kim Tyler, President, CEO and Director of Stratabound, an Alberta-registered corporation, trading under the symbol of “SB” on the TSX Venture Exchange and “SBMIF” on the OTCQB Venture Market. Stratabound’s head office is located at:

100 King Street West,
Suite 5700
Toronto, Ontario
M5X 1C7
Tel: 416-915-4157

This Report has an effective date of February 15, 2023.

The Report is prepared in accordance with the requirements of National Instrument 43-101 (NI 43-101) and in compliance with Form NI 43-101F1 of the Ontario Securities Commission (“OSC”) and the Canadian Securities Administrators (“CSA”). The Mineral Resource Estimates are considered to be compliant with the Canadian Institute of Mining, Metallurgy and Petroleum (“CIM”), CIM Standards on Mineral Resources and Reserves, Definitions (2014) and Best Practices Guidelines (2019) prepared by the CIM Standing Committee on Reserve Definitions.

2.2 SITE VISITS

Mr. Fred Brown, P.Geo., of P&E, a Qualified Person under the regulations of NI 43-101, conducted a site visit to the Fremont Property on March 24 and 25, 2022. At that time, an independent verification sampling program was conducted by Mr. Brown. The results of the verification sampling program are described in Section 12 of this Report.

Mr. Kirk Rodgers, P.Eng., of P&E, and Mr. Travis Manning, P.E., of KCA, both Qualified Persons under the regulations of NI 43-101, conducted a site visit to the Fremont Property on June 28, 2022. The purpose was to review the Property in terms of engineering aspects of the Project and inspect Property access and surface facilities.

2.3 SOURCES OF INFORMATION

In addition to the site visits, the authors (the “Authors”) of this Report held discussions with technical personnel from the Company regarding all pertinent aspects of the Project and conducted a review of available literature and documented results concerning the Property. The reader is referred to those data sources, which are outlined in the References section (Section 27) of this Report, for further details.

The Report is based, in part, on internal Company technical reports, and maps, published government reports, Company letters, memoranda, public disclosure and public information as listed in the References section. Sections from reports authored by other consultants have been directly quoted or summarized in this Report and are so indicated where appropriate.

The authors and co-authors of each section of this Report are presented in Table 2.1. In acting as independent Qualified Persons as defined by NI 43-101, they take responsibility for those sections of this Report as outlined in the “Certificate of Author” included in Section 28 of this Report.

Qualified Person	Contracted By	Sections of Technical Report
Mr. Andrew Bradfield, P.Eng.	P&E Mining Consultants Inc.	2, 3, 15, 19, 22, 24 and co-author 1, 16, 21, 25, 26, 27
Ms. Jarita Barry, P.Geo.	P&E Mining Consultants Inc.	11 and co-author 1, 12, 25, 26, 27
Mr. Fred Brown, P.Geo.	P&E Mining Consultants Inc.	Co-author 1, 12, 14, 25, 26, 27
Mr. Grant Feasby, P.Eng.	P&E Mining Consultants Inc.	20 and co-author 1, 25, 26, 27
Mr. Eugene Puritch, P.Eng., FEC, CET	P&E Mining Consultants Inc.	Co-author 1, 14, 25, 26, 27
Mr. Greg Robinson, P.Eng.	P&E Mining Consultants Inc.	Co-author 1, 16, 21, 25, 26, 27
Mr. Kirk Rodgers, P.Eng.	P&E Mining Consultants Inc.	Co-author 1, 16, 25, 26, 27
Mr. William Stone, Ph.D., P.Geo.	P&E Mining Consultants Inc.	4-10, 23 and co-author 1, 25, 26, 27
Mr. Travis Manning, P.E.	Kappes Cassiday & Associates	13, 17, 18 and co-author 1, 21, 25, 26, 27

2.4 UNITS AND CURRENCY

In this Report, all currency amounts are stated in US dollars (“\$”) unless otherwise stated. Commodity prices are typically expressed in US dollars (“US\$”). Quantities are generally stated in Système International d’Unités (“SI”) metric units including metric tons (“tonnes”, “t”) and kilograms (“kg”) for weight, kilometres (“km”) or metres (“m”) for distance, hectares (“ha”) for area, grams (“g”) and grams per tonne (“g/t”) for metal grades. Platinum group metal (“PGM”),

gold and silver grades may also be reported in parts per million (“ppm”) or parts per billion (“ppb”). Base metal values are reported in percentage (“%”) and parts per billion (“ppb”). Quantities of PGM, gold and silver may also be reported in troy ounces (“oz”), and quantities of base metals in avoirdupois pounds (“lb”). Abbreviations and terminology are summarized in Tables 2.2 and 2.3.

Grid coordinates for maps are given in the UTM NAD 83 Zone 10N or as latitude and longitude.

TABLE 2.2 TERMINOLOGY AND ABBREVIATIONS	
Abbreviation	Meaning
°	degree(s)
°C	degrees Celsius
\$	US dollar(s)
\$/t	dollars per tonne
\$M	dollars, millions
\$/m	dollars per metre
\$/oz	dollars per ounce
<	less than
>	greater than
%	percent
µm	micron or micrometre
3-D	three-dimensional
AAI	All Appropriate Inquiries
AAL	American Assay Laboratories
Actlabs	Activation Laboratories Ltd.
Ag	silver
AISC	all-in sustaining costs
ALS	ALS Minerals, part of ALS Global, ALS Limited (Australian Laboratory Services)
ANFO	ammonium nitrate/fuel oil mixture
Arrangement Agreement	Stratabound entered into a definitive arrangement agreement to acquire 100% of the issued and outstanding shares of California Gold Mining Inc., and all of California Gold’s assets.
APCD	Air Pollution Control District
APNs	Assessor Parcel Numbers
AUP	Administrative Use Permit
Au	gold
AuEq	gold equivalent
Authors, the	the authors of this Technical Report
Avg	average
Bondar Clegg	Bondar Clegg & Company Ltd.
C	carbon
CAC	California Administrative Code
California Gold	California Gold Mining Inc.

TABLE 2.2
TERMINOLOGY AND ABBREVIATIONS

Abbreviation	Meaning
CAPEX	capital costs
CCR	California Code of Regulations
CDFW	California Department of Fish and Wildlife
CEQA	California Environment Quality Act
CIL	carbon in leach
CIM	Canadian Institute of Mining, Metallurgy, and Petroleum
cm	centimetre(s)
CN	cyanide
Company, the	Stratabound Minerals Corp., the company that the report is written for
CO ₂	carbon dioxide
COG	cut-off grade
CoV	coefficient of variation
CRM	certified reference material
CSA	Canadian Securities Administrators
CUP	Conditional Use Permit
CV _{AV}	average coefficient of variation
CVG	calculated vertical gradient
CWA	Clean Water Act
DD or DDH	diamond drill hole
deg	degree
DEIR	Draft Environmental Impact Report
DEM	digital terrain model
dia.	diameter
DMBW	Derry Michener Booth & Wahl Consultants Ltd.
DSO	Deswik Stope Optimizer
E	east
EIR	Environmental Impact Report
EM	electromagnetic
ESA	Environmental Site Assessment
FAR	fresh air raise
Faverty	Faverty & Associates
ft	foot, feet
FW	footwall
FWQZ	Footwall Quartz Veins
EPCM	engineering, procurement and construction management
g	gram
g/L	grams per litre
g/t	grams per tonne
G&A	general and administration
GIS	geographic information system
Global Mining	Global Mining Explorations Ventures LLC

TABLE 2.2
TERMINOLOGY AND ABBREVIATIONS

Abbreviation	Meaning
Goldenbell	Goldenbell Mining Corporation
Goldrea	Goldrea Resources Corp.
gpm	gallons per minute
GPS	global positioning system
H	height (W x H)
H:V	horizontal to vertical ratio
H ₂ SO ₄	sulphuric acid
ha	hectare(s)
HDPE	high density polyethylene
HerSchy	HerSchy Environmental, Inc.
Hg	mercury
HLF	Heap Leach facility
HMBP	Hazardous Materials Business Plan
HR	hydraulic radius
hr	hour
HW	hanging wall
HWQZ	Hanging Wall Quartz Veins
ICP	inductively coupled plasma
ICP-OES	inductively coupled plasma- optical emission spectroscopy
ID	identification
ID ³	inverse distance cubed
in	inch(es)
INAA	Instrumental Neutron Activation Analysis
Inspectorate	Inspectorate America Corporation (rebranded as Bureau Veritas on October 1, 2018)
IP	induced polarization
IRR	internal rate of return
ISO	International Organization for Standardization
ISO/IEC	International Organization for Standardization / International Electrotechnical Commission
ITH	In-The-Hole Hammer
k	thousand(s)
KCA	Kappes, Cassiday & Associates
kg	kilograms(s)
kg/t	kilograms(s) per tonne
km	kilometre(s)
km ²	square kilometre(s)
koz	thousands of ounces
kt	thousands of tonnes
ktpa	thousands of tonnes per annum
kV	kilovolts, 1,000 volts

TABLE 2.2
TERMINOLOGY AND ABBREVIATIONS

Abbreviation	Meaning
kVa	kilovolt amps
kW	kilowatt
kWh	kilowatt hour
kWh/t	kilowatt hour per tonne
L	length (W x L)
L	litre(s)
L/s	litre(s) per second
lb	pound (weight)
lb/ton	pound(s) per ton
level	mine working level referring to the nominal elevation (m RL), e.g., 4285 level (mine workings at 4285 m RL)
LH	Longhole
LHD(s)	load-haul-dump (trucks)
LiDAR	Light Detection and Ranging
LLDPE	low-density polyethylene
LOM	life of mine
M	million(s)
m	metre(s)
m ³	cubic metre(s)
m ³ /s	cubic metre(s) per second
Ma	millions of years
MAR	Mariposa Zone
m asl	metres above sea level
MEL	Melange Zone
MgCl	magnesium chloride
MIBC	methyl isobutyl carbinol
min.	minute, time
MW	megawatts
mm	millimetre
Mm ³	millions of cubic metres
Moz	million ounces
MRE	Mineral Resource Estimate
Mt	mega tonne or million tonnes
Mtpa	millions of tonnes per annum
MW	megawatts
N	north
n	total number of items in the sample, statistics
NaCN	sodium cyanide
NAD	North American Datum
NEPA	National Environmental Protection Act
NGOs	Non-Governmental Organizations

TABLE 2.2
TERMINOLOGY AND ABBREVIATIONS

Abbreviation	Meaning
NI	National Instrument
Northwest	Northwest Gold Corp.
NN	Nearest Neighbour
NSR	net smelter return
nT	nanotesla, an SI unit of magnetic flux density
NPDES	National Pollutant Discharge Elimination System
NPV	net present value
OCM	oxide cap mineralization
OK	ordinary kriging
OPEX	operating costs
OREAS	OREAS North America Inc.
Org C	organic carbon
OSC	Ontario Securities Commission
OXC	oxide
oz	ounce
oz/t	ounce(s) per tonne
oz/ton	ounce(s) per ton
P ₈₀	80% percent passing
P&E	P&E Mining Consultants Inc.
PAX	potassium amyl xanthate
PEA	Preliminary Economic Assessment
P.Eng.	Professional Engineer
PF	paste backfill
PG&E	Pacific Gas and Electric Company
P.Geo.	Professional Geoscientist
Phase 1 ESA (2011)	Phase 1 Environmental Site Assessment in 2011 from HerSchy Environmental, Inc.
ppb	parts per billion
ppm	parts per million
Precision	Precision Gold LLC
psi	pounds per square inch
PTJ	Pine Tree-Josephine
Project, the	the Fremont Gold Property Project that is the subject of this Technical Report
Property, the	the Fremont Gold Property that is the subject of this Technical Report
Q1, Q2, Q3, Q4	quarter one, quarter two, quarter three, quarter four
QA	quality assurance
QA/QC	quality assurance/quality control
QC	quality control
QQ	quantile-quantile (plot)
QS	Queen Specimen

TABLE 2.2
TERMINOLOGY AND ABBREVIATIONS

Abbreviation	Meaning
QTZ	quartz
Queen Specimen	Queen Specimen-Succedo
R ²	coefficient of determination
RAR	return air raise
RC	reverse circulation
RECs	Recognized Environmental Concerns
Report, the	this Technical Report
RL	relative level
ROM	run of mine
RPA	Roscoe Postle Associates Inc.
RQD	rock quality designation
RV	Railveyor™
RWQCB	California Regional Water Quality Control Board
S	sulphur
s or sec	second, time
SEDAR	System for Electronic Document Analysis and Retrieval
SLR	SLR Consulting Limited
SMARA	Surface Mining and Reclamation Act
SO ₂	sulphur dioxide
SPCC	Spill Control Countermeasure Plan
SRK	SRK Consulting (Canada) Inc.
SRM	sulphide replacement material
Std Dev	standard deviation
Stratabound	Stratabound Mining Corp.
t	metric tonne(s)
t/h	tonnes per hour
t/m ³	tonnes per cubic metre
Technical Report	NI 43-101 Technical Report
TMI	total magnetic intensity
ton	short ton
tpa or tpy	tonnes per annum or tonnes per year
tpd	tonnes per day
tpy or tpa	tonnes per year or tonnes per annum
TR	trench
UG	underground
US\$	United States dollar(s)
USACE	US Army Corps of Engineers
USEPA	US Environmental Protection Agency
UTM	Universal Transverse Mercator grid system
V	volts
VLF-EM	very low frequency electromagnetics

TABLE 2.2
TERMINOLOGY AND ABBREVIATIONS

Abbreviation	Meaning
W	west
W	width (W x H)
WDRs	Waste Discharge Requirements
Wright	Wright Engineers Ltd.
Wt	weight
Wt %	weight percent
yr	year

TABLE 2.3
UNIT MEASUREMENT ABBREVIATIONS

Abbreviation	Meaning	Abbreviation	Meaning
µm	microns, micrometer	m ³ /s	cubic metre per second
\$	dollar	m ³ /y	cubic metre per year
\$/t	dollar per metric tonne	mØ	metre diameter
%	percent sign	m/h	metre per hour
% w/w	percent solid by weight	m/s	metre per second
¢/kWh	cent per kilowatt hour	Mt	million tonnes
°	degree	Mtpy	million tonnes per year
°C	degree Celsius	min	minute
cm	centimetre	min/h	minute per hour
d	day	mL	millilitre
ft	feet	mm	millimetre
GWh	Gigawatt hours	MV	medium voltage
g/t	grams per tonne	MVA	mega volt-ampere
h	hour	MW	megawatts
ha	hectare	oz	ounce (troy)
hp	horsepower	Pa	Pascal
k	kilo, thousands	pH	Measure of acidity
kg	kilogram	ppb	part per billion
kg/t	kilogram per metric tonne	ppm	part per million
km	kilometre	s	second
kPa	kilopascal	t or tonne	metric tonne
kV	kilovolt	tpd	metric tonne per day
kW	kilowatt	t/h	metric tonne per hour
kWh	kilowatt-hour	t/h/m	metric tonne per hour per metre
kWh/t	kilowatt-hour per metric tonne	t/h/m ²	metric tonne per hour per square metre
L	litre	t/m	metric tonne per month
L/s	litres per second	t/m ²	metric tonne per square metre

TABLE 2.3
UNIT MEASUREMENT ABBREVIATIONS

Abbreviation	Meaning	Abbreviation	Meaning
lb	pound(s)	t/m ³	metric tonne per cubic metre
M	million	T, ton	short ton
m	metre	tpy	metric tonnes per year
m ²	square metre	V	volt
m ³	cubic metre	W	Watt
m ³ /d	cubic metre per day	wt%	weight percent
m ³ /h	cubic metre per hour	yr	year

3.0 RELIANCE ON OTHER EXPERTS

The Authors have assumed, and relied on the fact, that all the information and existing technical documents listed in the References section of this Report are accurate and complete in all material aspects. Whereas the Authors have carefully reviewed all the available information presented to us, its accuracy and completeness cannot be guaranteed. The Authors reserve the right, but will not be obligated to revise the Report and conclusions if additional information becomes known to us subsequent to the effective date of this Report.

Copies of the land tenure documents, operating licenses, permits, and work contracts were not reviewed. Information relating to land tenure was reviewed by means of the public information available through the Mariposa County Assessor GIS Parcel Map website at: <https://www.mariposacounty.org/823/Maps-Property-Information/>. The Authors have relied upon this public information, and tenure information from Stratabound and has not undertaken an independent detailed legal verification of title and ownership of the Fremont Property. The Authors have not verified the legality of any underlying agreement(s) that may exist concerning the licenses or other agreement(s) between third parties, but have relied on, and considers that it has a reasonable basis to rely on Stratabound to have conducted the proper legal due diligence.

The Authors have relied upon Stratabound CFO Mr. Brendan Blair, B.Mgt, CPA, CA, for assistance with the taxation calculations in the financial model, as presented in section 22 of this Technical Report.

A draft copy of this Report has been reviewed for factual errors by the Company and the Authors have relied on Stratabound's knowledge of the Property in this regard. All statements and opinions expressed in this document are given in good faith and in the belief that such statements and opinions are not false and misleading at the effective date of this Report.

4.0 PROPERTY DESCRIPTION AND LOCATION

4.1 LOCATION

The Fremont Property is located in Mariposa County, California, 20.3 km (12.6 miles) northwest of Mariposa, and approximately 241 km (150 miles) east of San Francisco, in the western foothills of the Sierra Nevada Mountains (Figure 4.1). The Property is located in the southernmost portion of the prolific California Mother Lode Gold Belt. The centre of the Property is at approximately 754,360 m E and 4,164,460 m N (NAD83 UTM Zone 10N), or Longitude 120° 07' W and Latitude 37° 36' N.

FIGURE 4.1 **FREMONT PROPERTY LOCATION**

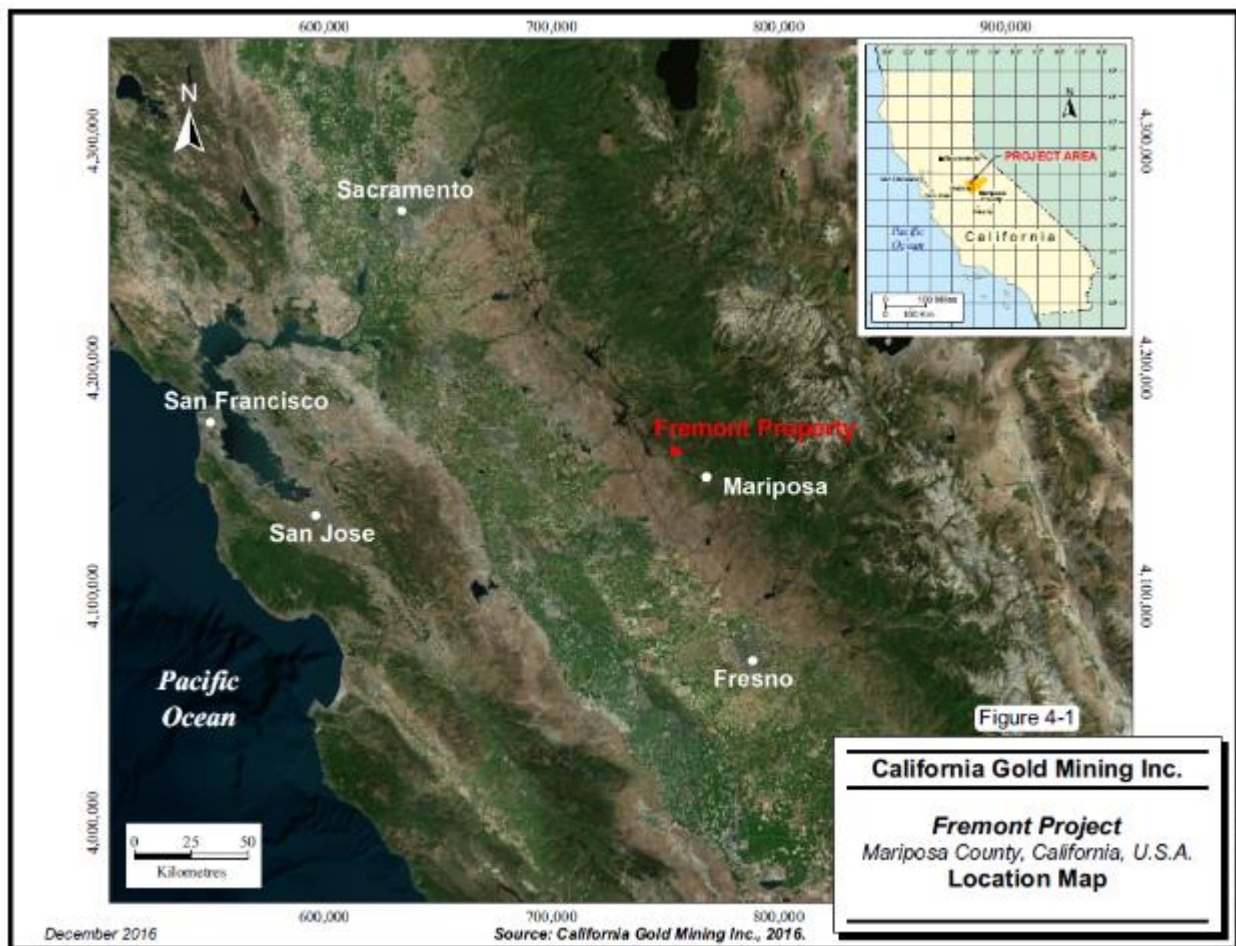

Source: SLR (2021)

4.2 PROPERTY ACQUISITION, MINERAL RIGHTS AND TENURE

In April 2021, California Gold Mining Inc. (“California Gold”) and Stratabound entered into a definitive arrangement agreement for Stratabound to acquire 100% of the issued and outstanding shares of California Gold Mining Inc., by way of a court-approved plan of arrangement under the Business Corporations Act (Ontario) (the "Arrangement Agreement"). Under the Arrangement

Agreement, Stratabound issued one common share for each common California Gold share. The acquisition includes all the assets of California Gold, including the Fremont Gold Project.

On May 3, 2021, Stratabound received Conditional Approval for the transaction by the TMX/TSX Venture Exchange, subsequent to which Stratabound forwarded requested documents, including the Fremont 2016 NI 43-101 Technical Report. On June 30, 2021, California Gold announced that greater than two-thirds of the shareholders voted to approve the transaction, thereby satisfying the two-thirds shareholder vote condition precedent.

On July 13, 2021, Stratabound announced that it had received final court approval for the plan of arrangement thereby satisfying the second condition precedent. On August 9, 2021, Stratabound received notice from the TSX Venture Exchange that it had accepted for filing documentation pursuant to the Stratabound’s arm’s length acquisition of all issued and outstanding securities of California Gold by way of the court-approved Arrangement Agreement.

On August 16, 2021, Stratabound announced that the transaction had closed and that California Gold had delisted. The Fremont Gold Project continues to remain under 100% ownership by Fremont Gold Mining LLC, a 100% wholly owned subsidiary of California Gold, which is now a 100% wholly owned subsidiary of Stratabound.

Fremont Gold Mining LLC owns the title, including the mineral and surface rights, to the three Assessor Parcel Numbers (“APNs”) 008-060-0030, 008-010-0040, and 008-010-0050 totalling 3,351.22 acres (1,357 ha) that comprise the Fremont Property (Table 4.1), including the land under State Highway 49 (Figure 4.2). Parcel Numbers 008-010-0030 and 08-010-0040 cover the Mineral Resources stated in Section 14 of this Report. All three Parcels are in good standing. The Property covers eight full and partial sections described as: Sections 4, 5, 8, 9, 10, 15, 16, and 17 Township 4 South, Range 17 East, Mount Diablo Base and Meridian.

TABLE 4.1					
FREMONT PROPERTY LAND INFORMATION *					
Assessor Parcel Number	Area (acres)	Owner	Ownership	Total Tax (\$)	Date Paid
008-060-0030	1,561.22	Fremont Gold Mining LLC	100%	29,172	09-May-22
008-010-0040	1,290.00	Fremont Gold Mining LLC	100%	22,913	09-May-22
008-010-0050	500.00	Fremont Gold Mining LLC	100%	8,868	09-May-22
Total	3,351.22	Fremont Gold Mining LLC	100%	60,952	

Source: Mariposa County Assessor GIS Parcel Map, June 2022

*Note: * Land Information effective February 15, 2023. All \$ values are in US\$.*

FIGURE 4.2 FREMONT PROPERTY MAP

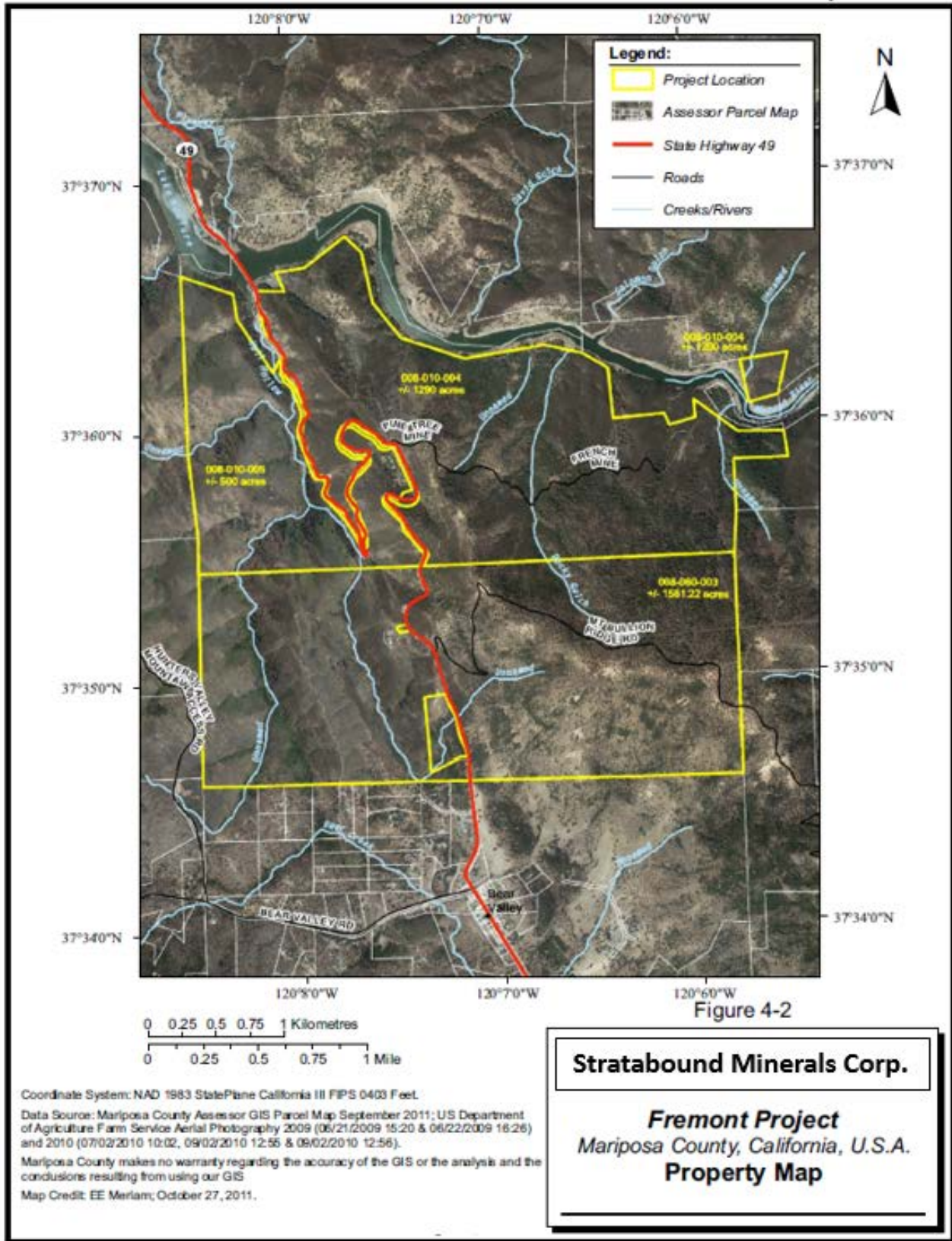

Source: SLR (2021)

The Property boundaries were surveyed by Ager, Beretta & Ellis Inc. of Vancouver, BC for Goldenbell Resources Corporation (a previous owner) in 1985 and by Freeman and Seaman Land Surveying for California Gold in 2016. Within the Property, there are three small parcels of land deeded to Pacific Gas and Electric Co. (“PG&E”) (i.e., 1.52 acres, Bear Valley substation), Mariposa County reclaimed dump site (29.26 acres), and the Merced Irrigation District (approximately 150 acres (61 ha) along the northern boundary). The only major structures on the Property are the office-warehouse located at 7585 Highway 49 and the PG&E electric power transformer substation.

4.3 ROYALTIES AND OTHER ENCUMBRANCES

The Fremont Property is subject to a 3% Net Smelter Return (“NSR”) royalty to a third party.

4.4 PERMITTING AND ENVIRONMENTAL

Exploration permits are issued by Mariposa County through an Administrative Use Permit (“AUP”) valid for a three-year period. The most recent permit was issued on October 2, 2017, and was subsequently extended to April 2, 2022. Stratabound resumed and concluded the AUP exploration work in March 2022, reclaimed the surface disturbance and received notice from the Mariposa County Planning Department that the AUP was successfully closed out on June 28, 2022. Depending upon the County Planning Departments review of proposed scope of any future exploration work an AUP, Conditional Use Permit (“CUP”) or Surface Mining and Reclamation Act (“SMARA”) permit may be applicable. Additionally, a county administered Grading Permit may be required where access roads are required.

Mariposa County is the lead agent for all county, state and federal permitting jurisdictions.

In October 2011, a Phase 1 Environmental Site Assessment (“Phase 1 ESA (2011)”) was completed on the Fremont Property by HerSchy Environmental, Inc. (“HerSchy”), as part of California Gold’s investigations made prior to its acquisition of the Property in 2012. That assessment was conducted in accordance with the American Society for Testing and Materials standard practice E1527-05 and is in compliance with the All Appropriate Inquiries (“AAI”) final ruling. The Phase 1 ESA (2011) reported that following a review of current and historical files and discussions with regulatory agencies, the site appears to have Recognized Environmental Concerns (“RECs”). The first REC related to the habitability of the warehouse has been rectified. The second is related to the historical mine tailings storage area from the 1940s, with respect to elevated arsenic and sulphate reported in the mine tailings. HerSchy concluded that historical and future tailings should be properly handled to prevent environmental impacts. However, no recommendations were made for any remediation.

The Authors are not aware of any environmental liabilities on the Property. The Authors are not aware of any other significant factors and risks that may affect access, title, or the right or ability to perform the proposed work program on the Property.

5.0 ACCESSIBILITY, CLIMATE, LOCAL RESOURCES, INFRASTRUCTURE AND PHYSIOGGRAPHY

5.1 ACCESS

The Fremont Property is readily accessible by California State Highway 49 (Figure 5.1). The Property is located mid-way between the Towns of Mariposa and Coulterville, approximately 241 km (150 miles) east-southeast of the City of San Francisco, California. The Town of Mariposa, with a population of 1,186 (2019 Census) is located 20.3 km (12.6 miles) south of the Property and is the nearest community with major infrastructure. State Highway 49 bisects the Property from north to south.

FIGURE 5.1 **FREMONT PROPERTY ACCESS**

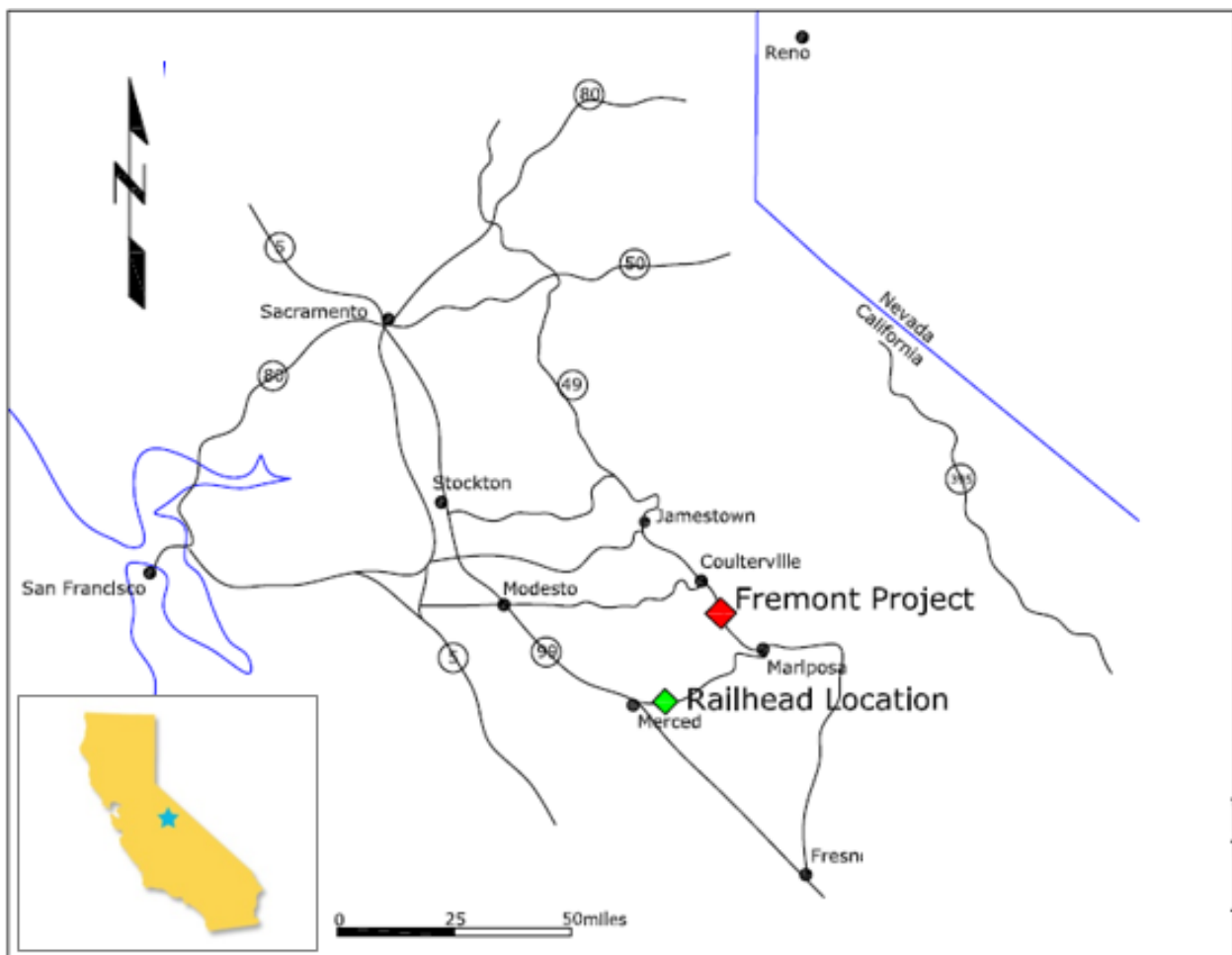

Source: Modified by P&E (2022) after Stratabound (March 2022).

5.2 CLIMATE

The climate is characterized by hot, dry summers with the highest average temperature of approximately 32°C in July and cool, wet winters, with the lowest average temperature of approximately 1°C in December-January (www.weatherspark.com). Average annual precipitation, including any snowfall, is approximately 79 cm (31 inches) (www.bestplaces.net), almost all of which occurs as rain between September and June. The area averages 269 sunny days per year. Exploration programs can be conducted year-round on the Property.

5.3 LOCAL RESOURCES

The Town of Mariposa, county seat for Mariposa County, has grocery stores, gas stations, hotels, restaurants, a domestic airport and is the main gateway to Yosemite National Park. Exploration-related supplies can be purchased in Mariposa from one of two hardware and supply stores.

The nearest urban centre is the City of Merced, located 60 km (37 miles) to the west-southwest of the Property. Merced is the county seat for Merced County, population 82,662 (2019 Census), and is the location of the nearest railhead.

5.4 INFRASTRUCTURE

California State Highway 49 bisects the Property from north to south and numerous private dirt roads provide access for mineral exploration and cattle grazing. A 70 kV power transmission line owned by PG&E traverses the Property from east to west. The local Bear Valley substation is located adjacent to Fremont Gold Mining LLC's office-warehouse, along Highway 49 (Figure 5.2).

5.5 PHYSIOGRAPHY

Topography is characterized by sloping uplands (Figure 5.3). The entire area drains northward to the Merced River. The majority of the Property area lies adjacent to the Merced River Valley, and ranges from 274 masl (900 ft) along the Merced River to over 1,036 masl (3,400 ft) on the northern end of Bullion Mountain in the southeast corner of the Property. The western third of the Property is within the Hell Hollow drainage system, which is a north-northwesterly trending canyon that hosts intermittent streams draining into the Merced River. In the southern portion of the Property, the uplands begin to level out and rolling woodland and grasslands are the dominant landforms.

Vegetation on the Property consists of scattered clumps of scrub oak with open grasslands in the southeast part of the Property and manzanita and chaparral covering steep gullies over the remainder of the Property. Pine trees, from which the Property name is derived, occur as isolated trees or in clumps and grow well on reclaimed waste dump sites.

FIGURE 5.2 FREMONT PROPERTY INFRASTRUCTURE

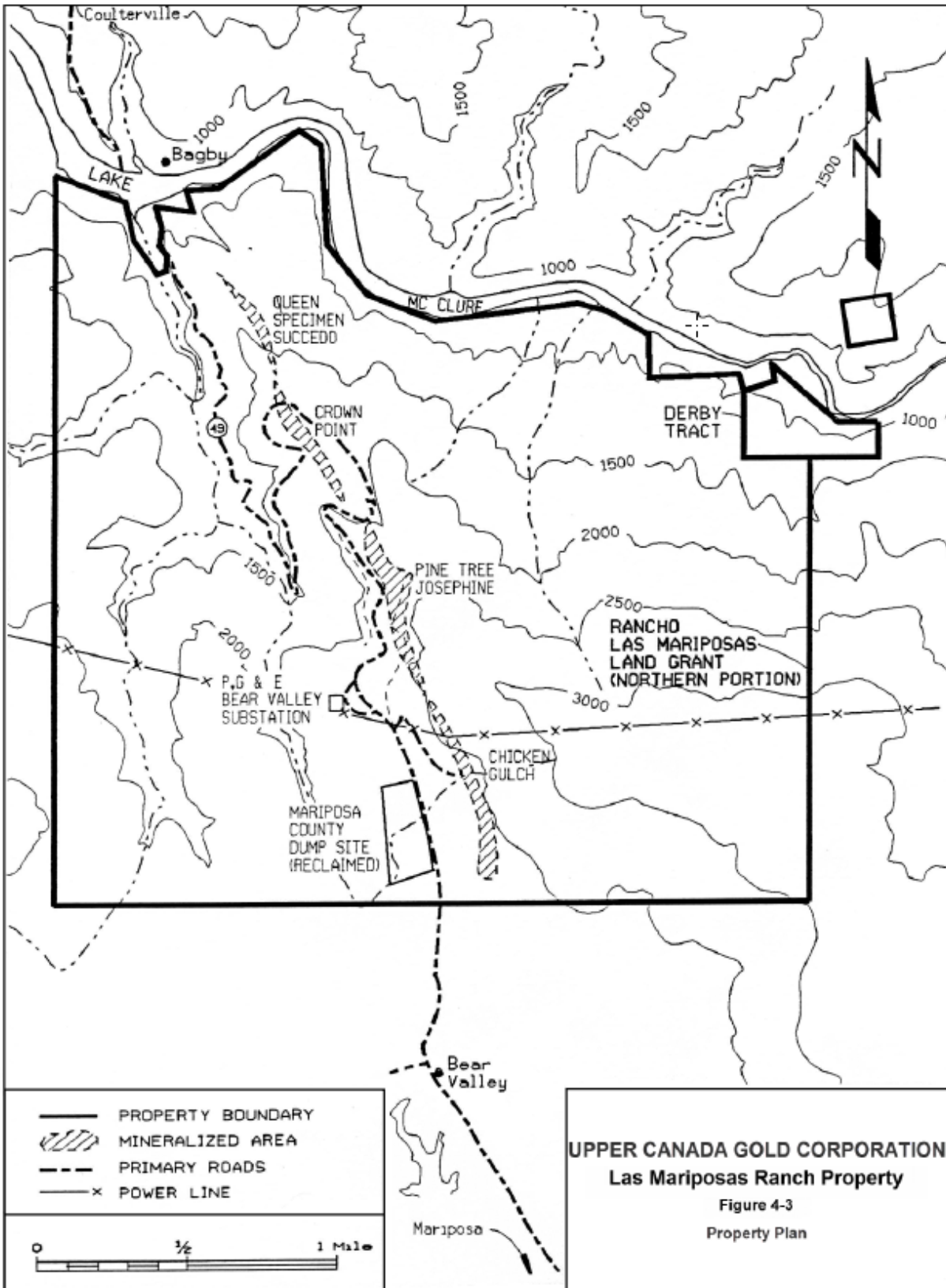

Source: Burgoyne (2013)

FIGURE 5.3 **FREMONT PROPERTY PHYSIOGRAPHY**



Source: Pohlman (2017)

Notes: View looking southwards. Highway 49 in the mid-ground and Fremont Mine office in the background.

6.0 HISTORY

The records of gold exploration and mining activities in the Fremont Gold Property area extend from the mid-19th century intermittently through to present-day. The main sources of information include Beacon Hill (1991), Smith (2008), and particularly Burgoyne (2013) and SLR (2021). The information has been organized by type and period of activity and summarized below. Collectively, the historical exploration and drilling programs resulted in the discovery of four main gold Deposits: Pine Tree-Josephine, Queen Specimen-Succedo (“Queen Specimen”), Crown Point, and Chicken Gulch (Figure 6.1).

FIGURE 6.1 GOLD DEPOSITS ON THE FREMONT PROPERTY

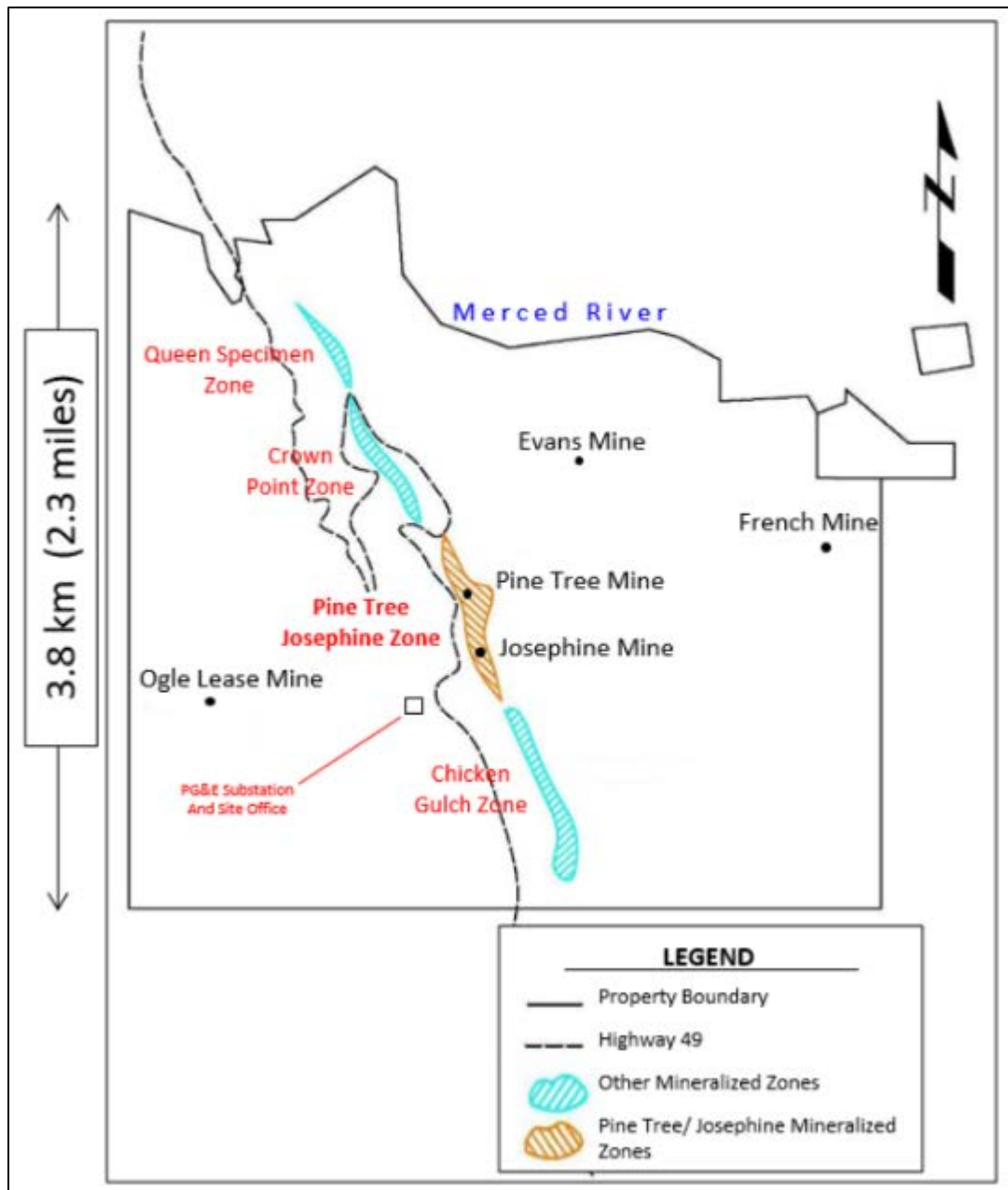

Source: California Gold (press release dated November 1, 2016)

6.1 PRIOR OWNERSHIP HISTORY

The Property consists of 1,357 ha (3,351 acres) of the northern portion of Las Mariposas Land Grant, which was granted to Juan B. Alvarado by the Governor and Commandant General of the Mexican Department of California while still a possession of Mexico on February 29, 1844 (Ford and Cochrane, 1984). The grant was purchased from Alvarado by John C. Fremont on February 10, 1847 prior to Mexico's cessation of California to the United States in the Treaty of Guadalupe Hidalgo in 1848 following the Mexican–American War. Gold was discovered in California at Sutters mill on January 24, 1848 sparking the California Gold Rush. Gold was discovered approximately 187 km (116 miles) further south along strike on the Fremont Property the following year in 1849. In 1887, the title of the land grant was acquired by Mariposa Commercial and Mining Company. The Property was subsequently acquired by the Pacific Mining Co. (subsidiary of A.J. Industries) in 1933 and mined until 1944. The title to the grant remained with A.J. Industries until A.J. Land Company acquired it in 1963. The Property was dormant until 1984.

The Property was acquired from A.J. Land Company in 1984, through a seven-year lease, by Goldenbell Mining Corporation (“Goldenbell”), a subsidiary of Goldenbell Resources Incorporated controlled by ABM Gold Corp. of Vancouver, BC. In mid-1988, Northgate Exploration Ltd. acquired the controlling interest of ABM Gold Corp. and through its US subsidiary, Northwest Gold Corp. (“Northwest”), the Pine Tree-Josephine Property.

After an unsuccessful effort to put the Pine Tree-Josephine Mine back into production, the Project lease expired and the Property was returned to A.J. Land Company in 1991. In 2004, A.J. Land Company transferred title of the Property to Mike Mondo, a trustee of the Mondo Trust, who in turn transferred it to the Gene Mondo and Betty Mondo Family, L.P.

In 2008, Global Mining Explorations Ventures LLC (Global Mining, later renamed Precision Gold LLC (“Precision”)) of Phoenix, Arizona, took a one-year option on the Property from the Mondo Family Trust and completed drilling of the tailings in Hell's Hole Gulch below the portal to the Pine Tree Mine, as reported in Smith (2008). Precision relinquished its Property option on July 1, 2009.

On March 30, 2011, John 3:16 LLC, an Arizona-based limited liability company, optioned the Property from Gene Mondo and Betty Mondo Family, L.P. On May 9, 2011, California Gold (then Upper Canada Gold Corporation) re-optioned the Property from John 3:16 LLC, with an option to acquire the Property from them and the right to compel John 3:16 LLC to exercise its option. The option and re-option arrangements were terminated by California Gold on September 29, 2011.

On October 11, 2011, John 3:16 LLC entered into a new option agreement with Gene Mondo and Betty Mondo Family L.P. giving John 3:16 LLC the right to acquire the Property until April 10, 2012. On January 20, 2012, California Gold purchased this option from John 3:16 LLC in consideration for US\$50,000 and a contingent commitment to pay John 3:16 US\$100,000 plus 3% of the purchase price that the company ultimately paid for the Property. The fees paid to John 3:16 LLC have been referred to as the finders' fee payable regarding California Gold's acquisition of the Property.

On January 26, 2012, California Gold announced that it had entered into a definitive purchase and sale agreement with Gene Mondo and Betty Mondo Family, L.P., the owner of the Property (the Vendor), whereby the company could designate any date until January 16, 2013 to complete the Property acquisition. On October 12, 2012, California Gold and the Vendor agreed that, in exchange for a US\$40,000 payment to the Vendor, California Gold could extend the closing date until April 16, 2013. On March 1, 2013, California Gold completed the purchase of the Property through its wholly owned subsidiary Fremont Gold Mining LLC. The purchase price consisted of aggregate consideration to the Vendor of US\$5,120,000, of which approximately US\$5,000,000 was paid on closing. California Gold also paid a third party an aggregate finder's fee of US\$303,600, of which US\$253,600 was paid on closing.

In April 2021, Stratabound entered into a definitive arrangement with California Gold to acquire 100% of the issued and outstanding shares of the latter, for all the assets of California Gold Mining Inc., including the Fremont Gold Project. On August 16, 2021, Stratabound announced that the transaction had closed and that California Gold had delisted as a public company. The Fremont Gold Project continues to remain under 100% ownership by Fremont Gold Mining LLC, a 100% wholly owned subsidiary of California Gold, which now exists as a 100% wholly owned subsidiary of Stratabound.

6.2 HISTORICAL MINERAL EXPLORATION

6.2.1 1984 to 2013

Exploration in 1984 by Goldenbell consisted of an evaluation of historical underground data, geological mapping, surveying, reconnaissance soil surveys, and induced polarization, very low frequency electromagnetic and magnetic surveys (Champigny, 1984). The 1985 geophysical and geochemical datasets were evaluated from 1 inch = 200 feet section plans by Kikauka (2003). Geophysical and geochemical anomalies ranging from very strong to very weak strength rankings for Au in soil, induced polarization (“IP”), VLF-EM and magnetometer surveys and shallow to deep depth rankings for IP and resistivity surveys, are given by Kikauka (2003). The ranking of the geophysical and geochemical anomalies and an evaluation of the respective anomalies (line-by-line) are presented in Tables 6.1 and 6.2.

TABLE 6.1
2003 RANKING OF GEOPHYSICAL AND GEOCHEMICAL ANOMALIES

Survey	Very Strong	Strong	Moderate	Weak	Very Weak	Shallow	Moderate	Deep
Au in soil	>1,000 ppb Au	501-1,000 ppb Au	101-500 ppb Au	21-100 ppb Au	>21 ppb Au	-----	-----	-----
IP Chargeability	-----	91 to 100 percentiles (relative ranking)	76 to 90 percentiles (relative ranking)	61 to 75 percentiles (relative ranking)	-----	0 to 200 ft (0 to 61 m) deep	201 to 400 ft (61 to 122 m) deep	>400 ft (>122 m) deep
IP Resistivity	-----	91 to 100 percentiles (relative ranking)	76 to 90 percentiles (relative ranking)	61 to 75 percentiles (relative ranking)	-----	0 to 200 ft (0 to 61 m) deep	201 to 400 ft (61 to 122 m) deep	>400 ft (>122 m) deep
VLF-EM (Fraser Filter)	-----	91 to 100 percentiles (relative ranking)	76 to 90 percentiles (relative ranking)	61 to 75 percentiles (relative ranking)	-----	-----	-----	-----
Magnetometer Total Field	>500 nT	301 to 500 nT	101 to 300 nT	50 to 100 nT	-----	-----	-----	-----

Sources: Kikauka (2003) and Burgoyne (2013)

TABLE 6.2
LINE-BY-LINE GEOPHYSICAL AND GEOCHEMICAL ANOMALIES EVALUATED IN 2003

Line (ft)	From (ft)	To (ft)	Length (ft)	Au in Soil	IP Chargeability	IP Resistivity	VLF-EM (Fraser Filter)	Magnetics Total Field
L 16000 N	17600 E	20600 E	3000	18100 E - weak 18300 E - very weak	No data	No data	19350 E - weak 19650 E - weak 19900 E - weak 20400 E - weak	19400 E - weak
L 18000 N	17900 E	20900 E	3000	18900 E to 19000 E - very weak 20900 E - weak	No data	No data	18100 E - weak 19050 E - weak 19200 E - weak 19450 E - moderate	
L 19500 N	17700 E	21100 E	3000	18200 E - weak 18900 E - weak	No data	No data	flat	flat
L 20800 N	18100 E	21200 E	3000	18900 E - very strong	No data	No data	19000 E - moderate 19350 E - weak 20100 E - moderate 20700 E moderate 20900 E - moderate	flat
L 22000 N	18300 E	21400 E	3000	19200 E - very strong 19500 E - very strong	19650 E - moderate strength at moderate depth 19900 E to 20100 E - moderate	19850 E - strong strength at shallow depth 20400 E to 20800 E - moderate	18850 E - weak 19500 E - weak 20300 E - weak	20050 E - moderate 20300 E - strong

TABLE 6.2
LINE-BY-LINE GEOPHYSICAL AND GEOCHEMICAL ANOMALIES EVALUATED IN 2003

Line (ft)	From (ft)	To (ft)	Length (ft)	Au in Soil	IP Chargeability	IP Resistivity	VLF-EM (Fraser Filter)	Magnetics Total Field
					strength at deep depth	strength at deep depth		
L 23500 N	18600 E	21600 E	3000	19800 E - very strong 20000 E - very strong	19900 E to 20100 E - moderate strength at deep depth 20700 E - weak strength at deep depth		19950 E - weak 20100 E - weak 20550 E - weak	20250 E - strong 20600 E - strong
L 25000 N	18300 E	21400 E	3000	19300 E - very weak 19600 E - very strong	19900 E to 20200 E - moderate strength at shallow to deep depth (overall - 60° dip to the east)	20200 E to 20300 E - strong strength at moderate depth 19500 E - strong strength at shallow depth	19850 E - moderate 20050 E - weak 20250 E - weak 20600 E - strong	20350 E - weak 20550 E - weak 20700 E - strong 20900 E - moderate 21350 E - strong
L 26500 N	19050 E	21700 E	3000	19700 E - strong 20300 E - moderate 20600 E - weak 20800 E - weak	2010 E to 20550 E - moderate strength at shallow to deep depth (overall - 60° dip to the east)	19750 E to 19850 E - moderate strength at shallow to deep depth (overall - 60° dip to the east)	19650 E - weak 20400 E - weak 21300 E - weak	20600 E to 20200 E - strong

TABLE 6.2
LINE-BY-LINE GEOPHYSICAL AND GEOCHEMICAL ANOMALIES EVALUATED IN 2003

Line (ft)	From (ft)	To (ft)	Length (ft)	Au in Soil	IP Chargeability	IP Resistivity	VLF-EM (Fraser Filter)	Magnetics Total Field
L 28000 N	19200 E	22100 E	3000	20000 E - moderate	20000 E to 20200 E - strong strength at deep depth	19750 E - strong strength at shallow depth 20900 E to 21000 E - moderate strength at shallow depth	19750 E - strong 20300 E - weak 20700 E - moderate	20300 E - very strong 20600 E - strong

Sources: Kikauka (2003) and Burgoyne (2013)

In 1984, an historical preliminary “geological reserve” estimate on the Pine Tree-Josephine Mines was completed, based on underground chip and muck car samples (see Section 6.3 below). In addition, the Pine Tree portal, adit, and underground workings were rehabilitated, and geological mapping and channel sampling completed. Bulk samples were taken for metallurgical test work. On the basis of this work, a reverse circulation (“RC”) drill hole program was completed in 1985 and 1986. Additional underground bulk sampling was completed in 1986 for metallurgical test work.

In 1985 and 1986, four separate targets were drilled: Pine Tree-Josephine, Queen Specimen, Chicken Gulch, and Crown Point (see Figure 6.1). A total of 22,065 m (72,393 ft) of surface drilling was completed on those targets, which included 19,860 m (65,158 ft) of RC drilling in 140 holes, 1,196 m (3,925 ft) of rotary drilling in 18 holes, and 1,009 m (3,310 ft) of core drilling in 16 drill holes.

The Pine Tree-Josephine target area, which contained the only historical mineral resource at that time on the Property, was explored by 16,494 m (54,113 ft) of vertically oriented RC drilling in 113 holes drilled nominally on 30 m (100 ft) centres with a grid north orientation of 330° (see Figure 6.2). The drill holes were at 30 m north-south intervals along mineralization trend and 21 m to 30 m (70 ft to 100 ft) intervals east-west. Except for the eight RC holes drilled at Queen Specimen (drill holes 133 to 140; Figure 6.3), the RC drill holes were vertical (Appendix H). A total of 27 west-east drill section lines, at 30 m intervals, were completed on Section lines 19,600 N to 22,300 N. The maximum depth drilled was 276 m (905 ft). Significant intercepts for the four targets drilled are listed in Appendix I.

In addition to the drilling, 19 surface trenches were excavated on the projected up-dip surface exposure of the Pine Tree-Josephine veins and mineralized host rock. The trenches varied from 11 m to 26 m (35 ft to 85 ft) in length.

In 2003, Goldrea Resources Corp. (“Goldrea”) optioned the Project and re-assayed a representative sample of pulps from the historical Goldenbell drill programs. Goldrea concluded that the geological resource was open to expansion in the footwall and to the southeast and northwest.

In 2008, Global Mining (later “Precision”) completed a 27 vertical hole drilling program totalling 165.06 m (538.25 ft) on the tailings in Hell’s Hole Gulch below the portal to the Pine Tree Mine (Smith, 2008) (Figure 6.4). The drilling program utilized a track-mounted sonic drill operated by Resonant Sonic International Drilling Company. Drilling of the tailings was done on a 30 m grid pattern and tested an area 171 m long and 142 m wide (560 ft by 465 ft) at the northwest end and 53 m wide (175 ft) at the southeast end of the tailings area. Bulk density data, detailed drill logs and assay results are presented in Smith (2008). Precision relinquished its option to the Property on July 1, 2009.

No exploration was completed on the Property between 2009 and 2013.

FIGURE 6.2 PINE TREE-JOSEPHINE DEPOSIT 1985-1986 RC DRILL HOLE LOCATIONS

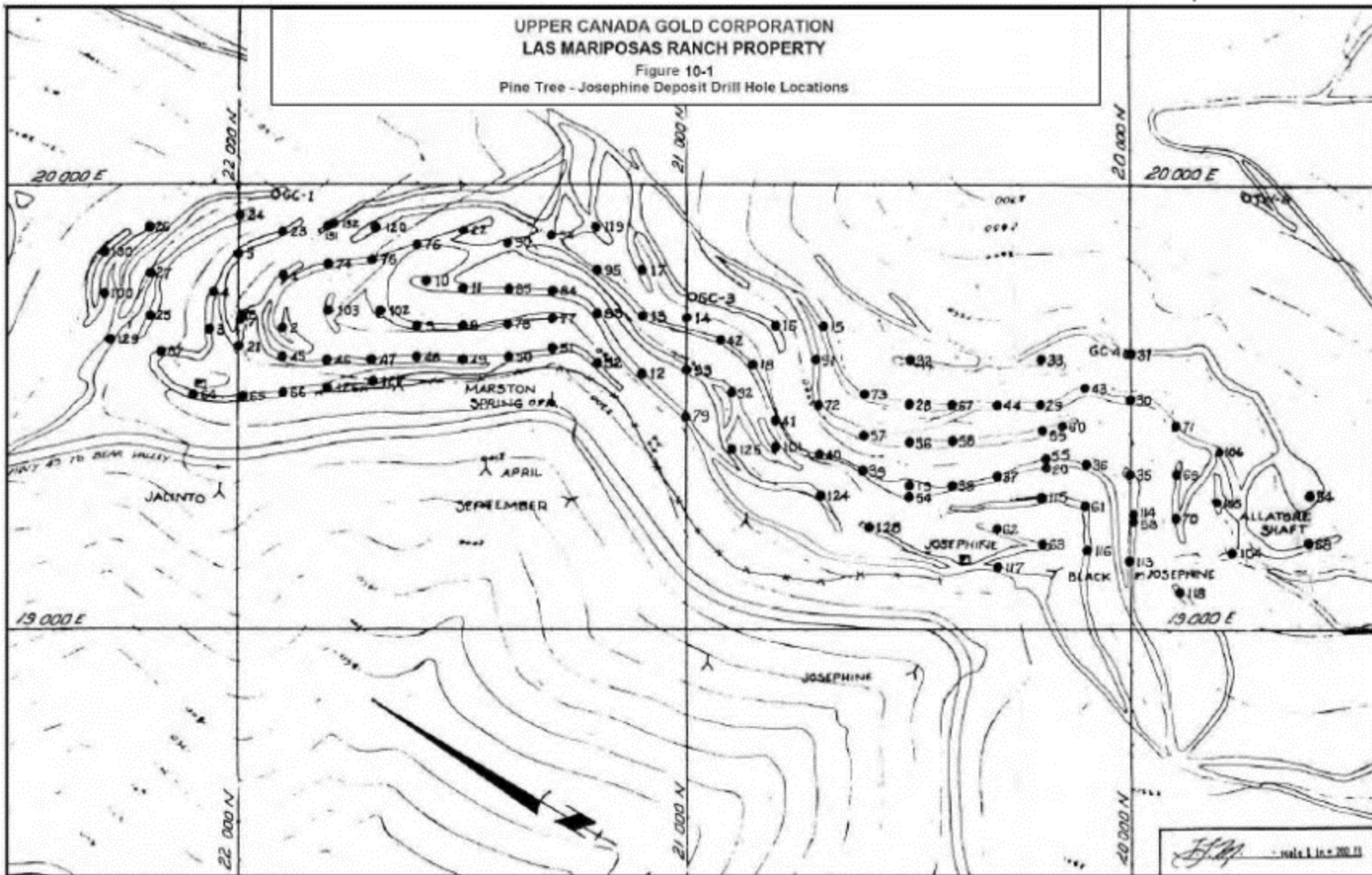

Source: Burgoyne (2013)

Note: Historically, the Fremont Property was known as the Las Mariposas Ranch Property.

FIGURE 6.3 QUEEN SPECIMEN DEPOSIT 1985-1986 RC DRILL HOLE LOCATIONS

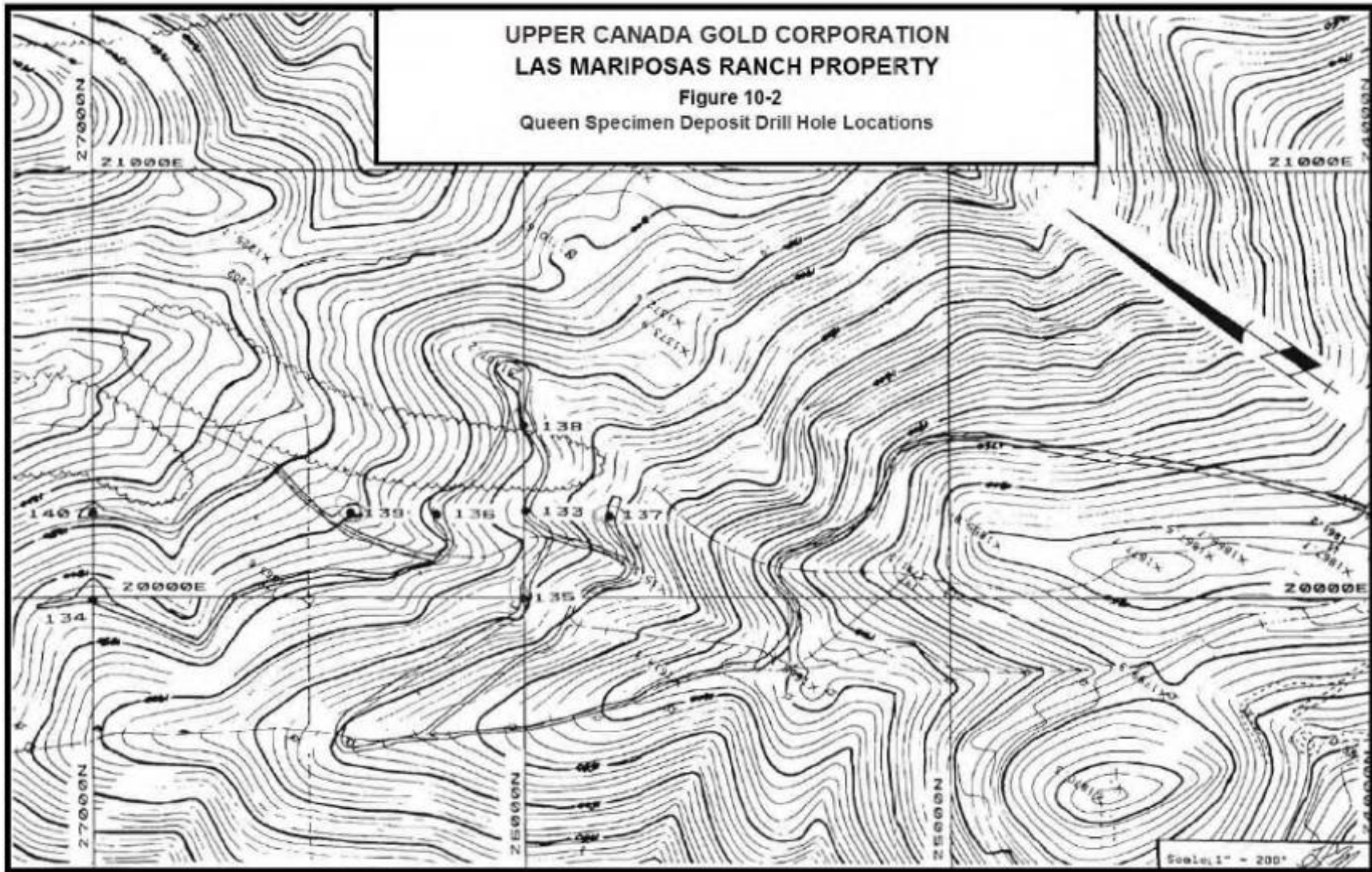

Source: Burgoyne (2013)

FIGURE 6.4 PRECISION 2008 DRILL HOLE AND TRENCH LOCATIONS



Source: Smith (2008)

6.2.2 2013 to 2021 California Gold

Since acquiring the Property in 2013, California Gold utilized geologic mapping, surface sampling, geophysical surveys, and RC drilling programs to identify drill targets in the Pine Tree–Josephine Deposit area and throughout the Property. The mapping, sampling and geophysical survey results have been summarized below. Highlights of the California Gold drilling programs are presented in Section 10 of this Report.

6.2.2.1 Geological Mapping

In 2014, California Gold undertook a property-wide geological mapping program at a 1:5,000 scale. This work refined the geology of the Property and identified five new target areas (Figure 6.5): 1) Golden Chain; 2) Vermont Slab; 3) Golden Slope; 4) Race Track Meadow; and 5) Ogle Canyon. In addition to this work, California Gold contracted SRK Consulting (Canada) Inc. (“SRK”) to complete a structural geology investigation of the Property. SRK completed structural and field mapping, drill core analysis, and produced a 3-D geological model to aid drill hole targeting.

FIGURE 6.5 MINERALIZED TARGETS RECOGNIZED DURING THE 2014 SURFACE MAPPING AND SAMPLING PROGRAM

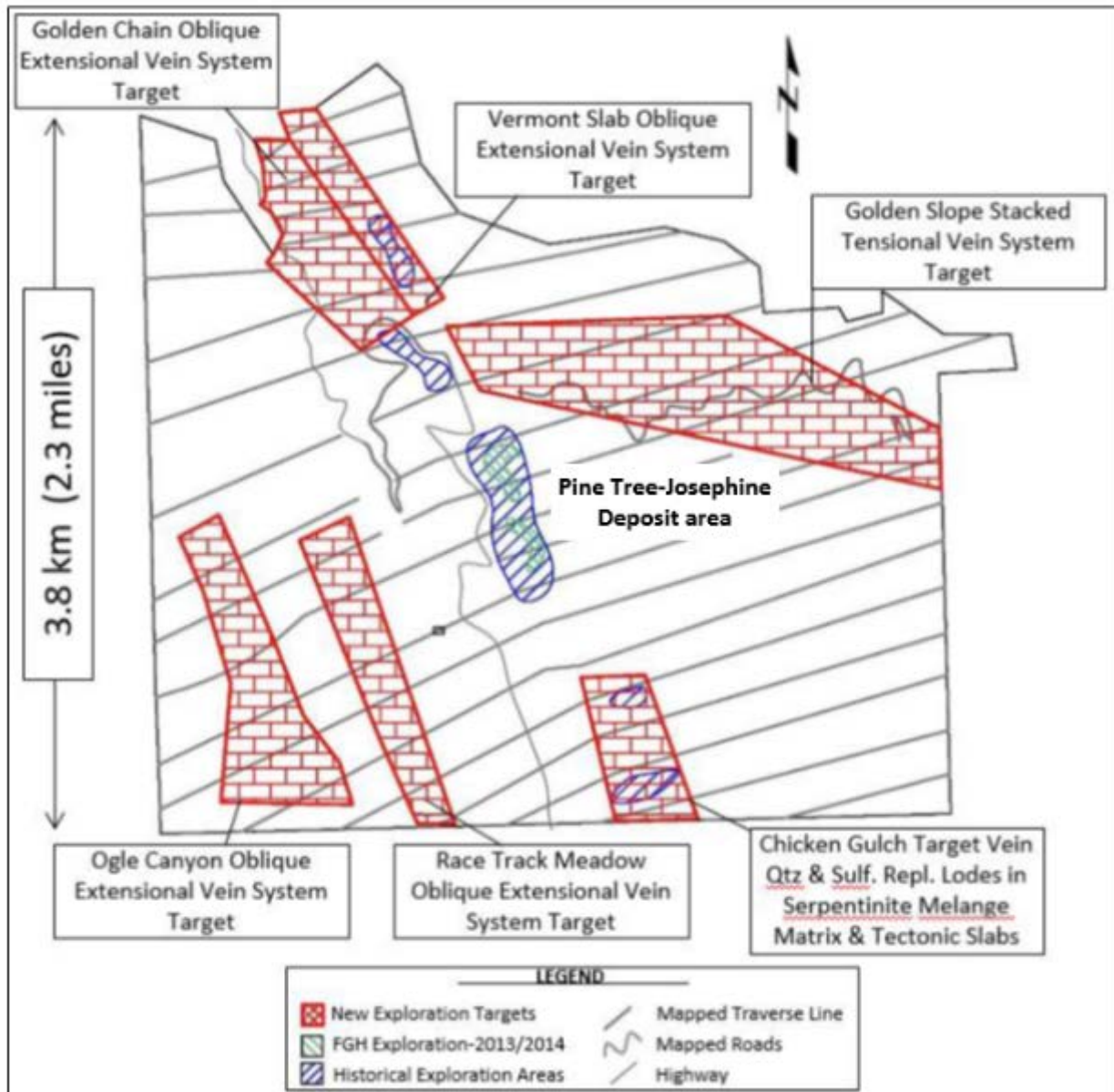

Source: California Gold (press release dated January 12, 2016)

6.2.2.2 Surface Sampling

In 2014, in addition to the mapping program, a surface sampling program was undertaken. Chip samples were taken from areas of quartz mineralization found during the mapping program. A total of 91 chip samples were collected. The chip sampling was completed along the Melones Fault Zone (the main structure associated with gold mineralization on the Property) and in areas of favourable geology. Individual chip samples were collected from outcrops scattered throughout the Melones Fault Zone and near road-cuts. Continuous chip samples ranged from 0.06 m to 1.95 m (0.2 ft to 6.4 ft). All samples were crushed and assayed by standard fire assay and

inductively coupled plasma (“ICP”) methods by American Assay Laboratories (“AAL”) in Sparks, Nevada.

6.2.2.3 Airborne Geophysical Survey

Geotech Airborne Geophysical Surveys flew a Helisting survey, a helicopter-borne gamma-ray and aeromagnetic geophysical survey, over the Property in October 2015 (GeoTech, 2015). The processed survey results included total magnetic intensity (“TMI”), calculated vertical gradient (“CVG”), digital terrain model (“DEM”), and gamma-ray spectrometry products (including uranium, thorium, and potassium). In late-2015, SRK interpreted the survey results, in order to establish a structural framework and map the distribution of fabrics, faults and major lithological units, and identify regional exploration drill targets on the Property (SRK, 2015). The structural interpretation results of their work are summarized in Section 7.4 of this Report.

6.3 HISTORICAL MINERAL RESOURCE AND MINERAL RESERVE ESTIMATES

6.3.1 Pine Tree-Josephine Deposit

Several historical mineral reserve estimates for the Pine Tree-Josephine Project were completed by independent consulting firms and by Northwest Gold (Beacon Hill, 1991; Burgoyne, 2013; SLR, 2021). Each of these historical mineral reserve estimates is summarized below.

The historical mineral resource and mineral reserve estimates summarized below are relevant because they demonstrate the exploration and development history of the gold mineralized deposits on the Property. However, the historical mineral resource and mineral reserve estimates should not be relied on and are not considered to be current Mineral Resources and Mineral Reserves. The historical mineral resources have been superseded by the current Mineral Resource Estimate described in Section 14 of this Report.

6.3.1.1 International Geosystems Corporation

The first historical “mineral reserve” estimate for the Pine Tree-Josephine Mine was completed in 1984 by International Geosystems Corporation (Vancouver, BC), on behalf of Goldenbell, prior to the signing of a lease with A.J. Land Co (Champigny, 1984). This was a conceptual study to determine if there was suitable exploration potential to warrant a major exploration program to define a gold deposit. A preliminary historical “geological reserve” estimate was completed based on 829 underground chip and 895 muck car samples. This estimate was based on a geostatistical block model using kriging. A minimum cut-off grade of 0.020 oz/ton Au over a minimum mineralized length of 7.6 m (25 ft) was used to produce gold grades for blocks having dimensions of 15.2 m x 15.2 m x 15.2 m (50 ft x 50 ft x 50 ft). The in-situ “geological reserves” in this study were 5.4 Mt (5.96 million tons) grading 2.64 g/t (0.077 oz/ton) Au (Table 6.3).

TABLE 6.3		
PINE TREE-JOSEPHINE 1984		
GEOLOGICAL RESERVE ESTIMATE		
Cut-off Grade (oz/ton Au)	Tons	Grade (oz/ton Au)
0.020	5,960,000	0.077

Sources: Champigny (1984), as summarized by Beacon Hill (1991) and Burgoyne (2013)

The purpose of this study was to determine if there was suitable exploration potential to warrant a major exploration program to define a major gold deposit. The exploration program was the 1985-1986 surface drilling program described above.

6.3.1.2 Wright Engineers (1986)

In November 1986, Wright Engineers Limited of Vancouver, BC completed a feasibility study on the Property and prepared historical “geological reserve” and historical “mineable reserve” estimates.

All contiguous samples over 0.51 g/t (0.015 oz/ton) Au from the drill hole intercepts and trench results were composited into “blocks”. Lithologic and mineralogical zones or envelopes were manually constructed and digitized. Grade interpolation was done for blocks that lay within a lithological envelope created from cross-sections. Bench plans were constructed at 12.2 m (40 ft) intervals and were assigned gold values via an Inverse Distance Squared interpolation, using a search ellipsoid 46 m (150 ft) in radius, oriented along strike and tilted down the dip angle of the gold mineralization. The search radius in the direction perpendicular to the dip was 15.2 m (50 ft), in the plane of the section. Previously mined out zones in the block model were assigned zero grade and no tonnage. The “geological reserve” was estimated to be 14.7 Mt (16.2 million tons) grading 2.13 g/t (0.062 oz/ton) Au (Table 6.4).

TABLE 6.4						
PINE TREE-JOSEPHINE 1986 HISTORICAL GEOLOGICAL RESERVES						
Mineralization Type¹	Proven		Probable		Total	
	Tonnage (k ton)	Grade (oz/ton Au)	Tonnage (k ton)	Grade (oz/ton Au)	Tonnage (k ton)	Grade (oz/ton Au)
4	693	0.033	---	---	693	0.033
5	4,503	0.063	487	0.053	4,990	0.062
6	4,897	0.068	183	0.068	5,080	0.068
7	4,697	0.062	286	0.045	4,983	0.061
8	365	0.041	40	0.041	405	0.041
9	17	0.034	---	---	17	0.034
Total	15,172	0.062	996	0.053	16,168	0.062

Source: Wright (1986) and SLR (2021)

Note: ¹Historical geology and gold zone classification.

Wright Engineers also estimated an historical “mineable reserve”, where an allowance was made for mining dilution and an open pit was designed. A pit bottom was outlined using the bench plans as a guide and pit walls were at varying angles. A mineable historical “reserve” contained within the designed pit was estimated at 13.5 Mt (14.93 million tons) grading 1.99 g/t (0.058 oz/ton) Au at a stripping ratio of 5.57:1 (Table 6.5).

TABLE 6.5 PINE TREE-JOSEPHINE 1986 HISTORICAL “GEOLOGICAL AND MINEABLE RESERVES”			
Type of Historical Reserve	Tonnage (ton)	Grade (oz/ton Au)	Total Ounces (oz Au)
Geological	16,168,000	0.062	1,002,416
Mineable	14,930,000	0.058	865,940

Source: Wright (1986) and SLR (2021)

6.3.1.3 Derry, Michener, Booth and Wahl (1988)

DMBW (Derry, Michener, Booth and Wahl) (1988) reported historical in-situ “geologic reserve” for the Pine Tree–Josephine area, based on assay and geological information from vertical RC drill holes and limited surface trenching and underground workings completed in 1985 and 1986. A cut-off grade of 0.86 g/t (0.025 oz/ton) Au over a minimum continuous drill intercept of 3 m (10 ft) and a tonnage factor of 2.67 t/m³ (12 ft³/ton) were utilized (Table 6.6). Note that “diorite ore” was distinguished, based on its lower grade and possible different metallurgical properties.

TABLE 6.6 PINE TREE-JOSEPHINE HISTORICAL “MINERAL RESOURCE ESTIMATE”			
Historical Resource (“Geologic Reserve”) Classification	Tons	Grade (Au oz/ton)	Contained Ounces¹
Drill Indicated	8,085,900	0.086	695,387
Drill Indicated "Diorite Ore" ²	204,200	0.040	8,168
Drill Indicated Total	8,290,100	0.085	704,659
Drill Inferred	1,597,300	0.078	124,589

Source: DMBW (1988) as reproduced by SLR (2021)

Notes:

¹ Contained ounces may differ due to rounding.

² "Diorite ore" was separated due to its relative low grade and possible different metallurgy.

6.3.1.4 Northwest 1988

In May 1988, Northwest commenced development of a geological and open pit block model for the Pine Tree–Josephine area utilizing similar parameters to the Wright Engineer’s study. A block model utilizing the Inverse Distance Squared method was set-up to determine the historical “geological reserves”. The geological correlations determined in the DMBW (1988) study to define boundary conditions and establish the search criteria were utilized. The model was set-up to allow both "ore" and waste composites to influence block grades, thereby creating a diluted block, which reflected the actual grades that would be encountered during mining. A mining block cut-off of 0.86 g/t (0.025 oz/ton) Au was utilized. The preliminary estimate within the model gave a historical “geological in-situ reserve” of 8.9 Mt (9,852,000 tons) grading 2.88 g/t (0.084 oz/ton) Au (Table 6.7). This estimate compared very closely to the DMBW (1988) estimate.

Year	Historical Classification	Cut-off Grade (oz/ton Au)	Tons	Grade (oz/ton Au)	Ounces Au (oz)
1988	Geological (in-situ) Reserve	0.025	9,852,000	0.084	827,000
1989	Mineable Reserve (open pit)	0.030	9,549,167	0.065	618,599

Sources: Beacon Hill (1991), Burgoyne (2013), SLR (2021).

Note: the 1989 estimate included 1,768,000 tons grading 0.065 oz/ton Au of open pit oxide.

A second historical “diluted in-situ” or “mineable reserve” was estimated in 1989 to include down-dip lower-grade mineralization (Table 6.7). The Northwest geological and block model was reviewed and audited by DMBW in August 1988, who concurred with the approach and methodology applied by Northwest. The model was re-run at various cut-off grades and it was found that a 0.93 g/t (0.027 oz/ton) Au cut-off grade would give the best return at the prevailing gold price of US\$425/oz. In February 1989, a historical open pit “mineable reserve” for the Pine Tree-Josephine mines of 8.7 Mt (9,549,167 tons) grading 2.23 g/t (0.065 oz/ton) Au (based on a 1.03 g/t (0.030 oz/ton) Au cut-off), contained 618,599 oz gold at a stripping ratio of 5.33:1. This historical “mineable” reserve used parameters of 5,450 tpd (6,000 tons per day) operation, \$1.04/t (\$0.94/ton) milling cost and \$7.79/t (\$7.07/ton) mining cost.

6.3.1.5 Beacon Hill 1988

A conceptual underground mining plan was developed by Beacon Hill, based on mineralization outlines and reserve projections made by Northwest Gold from surface drilling and underground sampling data. The work completed in the study focused predominantly on the underground requirements for a hypothetical bulk tonnage mechanized mining operation. Information and costs for the surface requirements of the project were obtained from Wright Engineers, and Knight and Piésold.

Underground mining above the Pine Tree level was not considered in the earlier Northwest Gold study. It was assumed that due to the presence of old workings and the weaker, oxidized rock near

surface, the major portion of this area would be more economically mined by open pit. However, some potential for additional underground mineral reserves was indicated at the south end of the zone beyond the economic open pit limits. The geological (*in situ*) reserves established as the basis for the Pine Tree underground study were as shown in Table 6.8.

TABLE 6.8		
PINE TREE-JOSEPHINE HISTORICAL UNDERGROUND GEOLOGICAL (IN SITU) RESERVES DECEMBER 1988		
Cut-off Au (oz/ton)	Tons	Grade Au (oz/ton)
0.05	9,040,000	0.123
0.06	7,536,000	0.132
0.07	7,036,000	0.136

Source: Beacon Hill (1988, 1991)

The potential underground mining reserves were estimated by Beacon Hill from the above *in-situ* reserve base and proposed mining plan. A mining recovery factor of 85% was applied and the in-situ reserves were diluted by 25% in tonnage at a grade equal to one half of the cut-off grade. After making adjustments for previously mined-out areas the diluted, recoverable mining reserves within the projected block were estimated as shown in Table 6.9.

TABLE 6.9		
PINE TREE-JOSEPHINE HISTORICAL UNDERGROUND MINING RESERVES DECEMBER 1988		
Cut-off Au (oz/ton)	Total Tons Mineable	Grade Au (oz/ton)
0.05	8,925,000	0.105
0.06	7,650,000	0.113
0.07	7,225,000	0.116

Source: Beacon Hill (1988, 1991)

In the subsequent financial analyses, the reserves at the 0.07 oz/ton (2.4 g/t) Au cut-off were used as the base case. Sensitivity analyses were conducted on the 0.05 oz/ton and 0.06 oz/ton (1.7 g/t and 1.0 g/t) Au cut-offs.

6.3.1.6 Precision Gold (2008)

In 2008, Precision Gold reported an historical mineral resource of 74,600 t (82,237 tons) grading 0.89 g/t (0.026 oz/ton) Au for Pine Tree tailings (Smith 2008) (Table 6.10). This historical mineral resource was based on the 27 vertical hole drilling program totalling 164 m (538.25 ft) completed on the tailings in Hell's Hole Gulch below Pine Tree Mine portal.

TABLE 6.10			
PINE TREE TAILINGS RESOURCES - OCTOBER 2008			
Tailings	Tons	Grade (oz/ton Au)	Contained Gold (oz)
Pine Tree Mine	82,237	0.026	2138

Source: Smith (2008)

Note: cut-off grade not provided.

This historical resource estimate for the tailings is not separated into categories/classifications, does not meet Canadian Institute of Mining, Metallurgy and Petroleum (“CIM”) Definition Standards for Mineral Resources and Mineral Reserves, and cannot be relied upon.

6.3.2 Queen Specimen Deposit

Historical mining reserve estimates of the Queen Specimen Deposit were completed by Wright Engineers (1986) and Northwest Gold Corp. (1988). These mining reserve estimates are summarized in Table 6.11. Geological (*in situ*) reserve estimates were not reported.

TABLE 6.11						
QUEEN SPECIMEN HISTORICAL “MINING RESERVES”						
Group	Year	Model	Material	Tons	Grade (oz/ton Au)	Contained Metal (oz Au)
Wright Engineers	1986	open pit		2,460,000	0.058	143,000
Northwest Gold Corp.*	1988	open pit	oxide plus sulphide	1,970,000	0.064	126,000
		open pit	oxide	500,000	0.058	29,000
		open pit	sulphide	1,470,000	0.066	97,000

Sources: Wright (1986), Beacon Hill (1991), Burgoyne (2013), SLR (2021)

*Note: * Beacon Hill (1991) reported that this estimate included 500,000 tons grading 0.058 oz/ton gold of open pit oxide “mining reserve” amendable to heap leaching at a strip ratio of 4.28.*

The mining reserve estimate completed by Wright Engineers was based on 853 m (2,800 ft) of inclined reverse circulation drilling from eight drill holes completed on four separate geological cross-sections. The estimate was apparently calculated manually. An open pit with wall angles of 45° and 10% access ramp was designed to mine at a stripping ratio of 6.48:1. This historical “mineable reserve” given by Wright Engineers was 2.23 Mt (2.46 million tons) grading 1.99 g/t (0.058 ounces per ton) Au.

Northwest Gold completed a block model for the Queen Specimen Deposit in 1989 using the same principles and parameters as for the Pine Tree-Josephine Deposit. The block model was based on data from eight inclined reverse circulation holes drilled on four separate east-west sections (25800, 26000, 26200, 26400 North) spaced 61 m (200 ft) apart. This relatively wide drill hole-spacing and sparse amount of data meant that the historical “reserves” were classified as

inferred. Additional drilling was required to upgrade the confidence of this Deposit to the same level as the Pine Tree-Josephine Deposit. A “final” pit was generated using similar design parameters, and an open pit historical “mining reserve” was estimated at 1.79 Mt (1,970,000 tons) grading 2.19 g/t (0.064 ounces per ton) Au containing 126,000 ounces gold at a 4.28:1 stripping ratio. Beacon Hill (1991) reported that this included 454,000 t (500,000 tons) grading 1.99 g/t (0.058 ounces per ton) Au of open pit oxide “mining reserve” amenable to heap leaching at a stripping ratio of 4.28:1 and 1.33 Mt (1,470,000 tons) grading 2.26 g/t (0.066 oz/ton) Au of open pit sulphide “mining reserve”.

6.4 RECENT AND PREVIOUS MINERAL RESOURCE ESTIMATES

Recent and previous Mineral Resource Estimates have been reported by RPA and SLR in 2016 and 2021, respectively.

6.4.1 RPA 2016 Mineral Resource Estimate

In 2016, California Gold reported a Mineral Resource Estimate completed by RPA for the Pine Tree-Josephine Deposit, based on a conceptual open pit mining method (Table 6.12). This Mineral Resource included 9,362,000 t at an average grade of 1.71 g/t Au, containing 515,000 ounces in the Indicated Mineral Resource classification, and 7,850,000 t at an average grade of 1.44 g/t Au, containing 364,000 ounces in the Inferred Mineral Resource classification. The Mineral Resources were estimated at a 0.5 g/t Au cut-off grade, based on a US\$1,400/oz price of gold. The Mineral Resource Estimate was based on results from 25,970.3 m of drilling in 162 drill holes, in the Pine Tree-Josephine area.

Classification	Tonnes (kt)	Grade Au (g/t)	Contained Metal Au (koz)
Indicated	9,362	1.71	515
Inferred	7,850	1.44	364

Source: RPA (2016)

Notes:

1. CIM definitions were followed for classification of Mineral Resources.
2. Mineral Resources are estimated at a cut-off grade of 0.5 g/t Au.
3. Mineral Resources are estimated using a gold price of US\$1,400 per ounce.
4. The Mineral Resources are constrained by a Whittle pit shell.

6.4.2 SLR 2021 Mineral Resource Estimate

In 2021, Stratabound reported an updated Mineral Resource Estimate completed by SLR (2021) for the Pine Tree-Josephine Deposit, based on a conceptual open pit mining method (Table 6.13). This Mineral Resource included 10,236,000 t at an average grade of 1.60 g/t Au, containing 526,000 ounces in the Indicated Mineral Resource classification, and 10,920,000 t at an average

grade of 1.29 g/t Au, containing 452,000 oz in the Inferred Mineral Resource classification. The Mineral Resources were estimated at a 0.4 g/t Au cut-off grade, based on a price of US\$1,800/oz gold. The Mineral Resource Estimate was based on results from 25,970.3 m of drilling in 162 drill holes, in the Pine Tree-Josephine area. Subsequent to the preceding historical 2016 Mineral Resource Estimate conducted by RPA, 21 diamond drill holes were completed on the Queen Specimen Deposit, approximately 1 km north of the Pine Tree-Josephine Deposit. However, the Queen Specimen Deposit drilling was not included in the 2021 updated Mineral Resource Estimate reported for the Pine Tree-Josephine Deposit.

TABLE 6.13 PINE TREE-JOSEPHINE MINERAL RESOURCE ESTIMATE - AUGUST 31, 2021			
Classification	Tonnes (kt)	Grade Au (g/t)	Contained Metal Au (koz)
Indicated	10,236	1.60	526
Inferred	10,920	1.29	452

Source: SLR (2021)

Notes:

1. CIM definitions were followed for classification of Mineral Resources.
2. Mineral Resources are estimated at a cut-off grade of 0.4 g/t Au.
3. Mineral Resources are estimated using a gold price of US\$1,800/oz.
4. The Mineral Resources are constrained by a Whittle pit shell.

The reader is cautioned that the 2021 updated Mineral Resource Estimate for the Pine Tree-Josephine Deposit is superseded by the current Mineral Resource Estimate described in Section 14 of this Report.

6.5 PAST PRODUCTION

Mining at Pine Tree, Josephine, and Queen Specimen Deposits commenced in the early 1850s. The Pine Tree and Josephine Mines operated almost continuously until the early 1870s. Production records for the operating years are incomplete and there are no records available for 20 years of operation including the first 10 years of operation and another 10 years from 1865 to 1875. The total production reported therefore, is the minimum production.

The Pine Tree-Josephine workings re-opened in the early 1930s, when the operation was taken over by Pacific Mining Co. A 91 tpd (100 tons per day) flotation process plant was constructed near the portal of the Pine Tree adit and an extensive exploration, development, and bulk sampling program was undertaken to evaluate the large-scale mining potential of the lower-grade mineralization.

Between 1933 and 1944, the Pine Tree level was connected with the Josephine workings, and the Mackenzie shaft deepened to 396 m (1,300 ft). Production totalled 430,000 t (475,000 tons) of mineralized material, which accounts for 72% of the known historical production. Mining of the lower-grade “inter-vein” mineralization on a large-scale did not materialize and operations

were suspended in 1945. Historical gold production from the Pine Tree–Josephine Mines is summarized in Table 6.14 (Bowen and Gray, 1957).

Period	Tonnage (ton)	Calculated Grade Au (oz/ton)	Production Au (oz)
1849-1859	n/a	n/a	n/a
1860	12,154	0.452	5,494
1861	21,576	0.39	8,415
1863	11,270	0.268	3,025
1865-1875	n/a	n/a	n/a
1875-1900	n/a	n/a	n/a
1900-1915	20,968	0.858	18,452
1916-1932	inactive	n/a	n/a
1933-1937	170,943	0.28	47,864
1938	55,021	0.141	7,758
1939-1944	248,481	0.142	35,215
Total	540,413		126,223

Source: Burgoyne (2013)

Beacon Hill (1991) report that the Queen Specimen Deposit was mined between 1850 and 1859, and again between 1908 and 1915. From 1922 to 1924, 2,722 t (3,000 tons) of mineralized material and tailings from previous operations were treated in a 9 tpd (10 tons per day) stamp mill. In June 1874, an adit was started from the south bank of the Merced River at Benton Mills. Work was terminated after 1,015 m (3,330 ft) of drifting and development commenced on the Succedo Mine below the Queen Specimen workings, where a shaft and five levels were developed, and a minimal amount of stoping was completed. Limited mining and development occurred between 1875 and 1898. Development resumed in 1899, with the driving of the Josephine winze and excavation of the inclined Mackenzie shaft at the north end of the Pine Tree Mine to a depth of 150 m (493 ft). Between 1900 and 1915, production amounted to approximately 19,051 t (21,000 tons) of mineralized material, which was processed in the Princeton Mill, near Mount Bullion.

6.6 HISTORICAL FEASIBILITY STUDIES

The following summary is based on SLR (2021).

During 1986, work commenced on a comprehensive permitting process, and Wright Engineers Ltd. (“Wright”) of Vancouver, BC subsequently completed a four-volume Feasibility Study from 1986 to 1989 (Wright, 1986, 1988, 1989). The studies indicated that an economically viable open pit operation could be developed on the Property, which would require the construction of a roaster-acid process plant facility. In 1989, Wright completed a heap leach pre-feasibility study

report that presented results of heap and pit design work, reserve estimation, and the economics of mining the open pit oxide mineralization on the Pine Tree-Josephine Deposit. This heap leach study, at the time, was considered potentially viable, subject to certain imposed conditions of tonnage and operating and capital costs.

On acquisition of the Property, Northwest carried out metallurgical test work and detailed planning studies, which indicated that capital costs would be significantly higher than originally anticipated and, based on the prevailing gold price, the Property was deemed uneconomic. Also, delays in the permitting process and the completion of costly additional studies were requested before the Environmental Impact Report could be certified. During 1988 and 1989, Northwest conducted a number of development and mine plan studies and re-evaluations of the Pine Tree Project to improve the economics and minimize the environmental impact of developing the existing “reserves”. During 1988, a historical “geological reserve” study was completed by Derry, Michener, Booth and Wahl (1988) of Denver, Colorado. The Pine Tree open pit plan “reserve” was re-evaluated in order to reduce strip ratio and increase grade. An open pit plan was also developed for the Queen Specimen Deposit. A study was commissioned to determine if additional drilling was warranted to confirm the extension of the mineralized structure at depth.

An extensive amount of metallurgical test work was completed between early 1986 and February 1988. Minor work was conducted through to March 1990. A final comprehensive Project report by Beacon Hill was issued in April 1991. The Beacon Hill report considered all aspects of Pine Tree-Josephine Mine development that occurred from 1984 to 1990 (Beacon Hill, 1991).

6.7 HISTORICAL UNDERGROUND STUDIES

The following summary is taken largely from SLR (2021).

Beacon Hill (1988, 1991) completed conceptual studies of the underground mining potential at the Pine Tree-Josephine Deposit. The study was based on known resources and resource projections made from existing geological data (see Tables 6.8 and 6.9 above). A mining plan was developed for a mechanized bulk mining operation, using sub-level longhole stoping, to produce 2,250 t to 3,600 t (2,500 tons to 4,000 tons) of mineralized material per day. The results of the studies indicated that an underground mine was a potentially viable option if resources and subsequently developed reserves in the range of 8.2 Mt to 10 Mt (9 million to 11 million tons) grading 3.77 g/t to 4.11 g/t (0.11 oz/ton Au to 0.12 oz/ton) Au could be delineated.

6.8 HISTORICAL ENVIRONMENTAL STUDIES

The following summaries are based largely on Burgoyne (2013) and SLR (2021).

In 1987 and 1988, a three-volume Environmental Report was completed for Goldenbell. The report consisted of a Draft Environmental Impact Report by Faverty & Associates (1987), a Reclamation Plan by Cedar Creek Associates, Inc. (1987), and Comments and Responses to the Draft Environmental Impact Report by Faverty & Associates (1988). The Draft EIR included an exhaustive study on water quality from several stations monitoring springs, groundwater and surface water, in undisturbed areas and in the historical mining areas. Waters are somewhat alkaline and concentrations of dissolved arsenic, manganese, nickel, and strontium at the old mine

areas are higher than those observed in the undisturbed areas. At the old mine workings, only arsenic and manganese were present at levels higher than the Maximum Containment Level for waters in California.

The permitting process commenced in March 1986 with the filing of a Mining Permit Application and Project Description Report with the Mariposa County Planning Department. Northwest began a comprehensive environmental monitoring and investigation program to provide technical input necessary for the preparation of an EIR. A draft EIR was submitted to the county Planning Department in September 1987 and after a period of public review, a final EIR was submitted in March 1988.

In 2011, California Gold (then Upper Canada Gold Corp.) commissioned a detailed Phase 1 Environmental Site Assessment from HerSchy Environmental, Inc. (the “Phase 1 ESA (2011)”). This assessment was conducted in accordance with the American Society for Testing and Materials standard practice E1527-05, to comply with the All Appropriate Inquiries (“AAI”) final ruling. The Phase 1 ESA (2011) reported that following a review of current and historical files and discussions with regulatory agencies, the site does have Recognized Environmental Concerns (“RECs”) mostly related to the habitability of the office-warehouse building located on Highway 49 and the historical mine tailings area. According to Burgoyne (2013), California Gold advised that the office building was cleaned and habitable in 2013. The Phase 1 ESA (2011) also concluded that there is elevated arsenic and sulphate reported in the mine tailings. HerSchy Environmental concluded that historical and future tailings should be properly managed to prevent environmental impacts and no recommendations were made for any remediation.

7.0 GEOLOGICAL SETTING AND MINERALIZATION

7.1 REGIONAL GEOLOGY

The Fremont Property is located at the southern tip of the western Sierra Nevada Foothills Metamorphic Belt. This Belt is divided into five geologic packages (Snow and Scherer, 2006): 1) the Northern Sierra Terrane; 2) Feather River Terrane; 3) Calaveras Complex; 4) Jura-Triassic Arc Belt; and 5) Middle–Late Jurassic Arc Sequence (Figure 7.1). Following emplacement of the Northern Sierra Terrane and Feather River Terrane, the geological evolution of the region was dominated by arc volcanism and accretion. The entire Sierra Nevada Foothills Metamorphic Belt was likely accreted to the continental margin of North America by the Late Jurassic period. The Jura-Triassic Arc Belt and the Middle–Late Jurassic Arc Sequence are separated by the Melones Fault Zone and the Bear Mountain Fault Zone.

The Melones Fault Zone bisects the Property and separates the Jura-Triassic Arc Belt to the east and the Middle–Late Jurassic Arc Sequence to the west. The eastern Jura-Triassic Arc Belt is a northeast-southwest-trending belt consisting of a Paleozoic basement of disrupted ophiolite, serpentinite mélange, and ultramafic rocks overlain by uppermost Triassic–Early Jurassic arc volcanics and coeval 200 Ma intrusive rocks. The western Middle–Late Jurassic Arc Sequence (also trending northeast-southwest) consists of 165 Ma to 155 Ma volcanic arc rocks, greenstones, and metasedimentary rocks of the Mariposa Formation (Snow and Scherer, 2006). Lithological units are bound by steep faults, melange, or both, although depositional contacts may be found locally.

7.2 REGIONAL GOLD DISTRICTS

Three major gold districts are hosted in the western Sierra Nevada Foothills Metamorphic Belt: 1) the Mother Lode Gold District; 2) Grass Valley Gold District; and 3) Alleghany Gold Districts. The Grass Valley Gold District occurs along the Bear Mountain Fault Zone. The Mother Lode and Alleghany Gold Districts occur along the Melones Fault Zone, which is a major, crustal-scale, north-northwesterly trending fault zone (Figure 7.2). During the Early Cretaceous, this reverse fault system was reactivated in a transpressive regime, resulting in gold mineralization at approximately 125 ± 10 Ma (Goldfarb *et al.*, 2008).

The Fremont Property is located at the southern tip of the Mother Lode Gold District. The Mother Lode Gold District is characterized by a series of en echelon quartz veins, discontinuous silica-ankerite alteration zones, and ultramafic breccias associated with the Melones Fault Zone. The Melones Fault Zone varies in width from 60 m to more than 1.6 km and extends for a length of 200 km along the western foothills of the Sierra Nevada from the Greenwood-Georgetown area in the north to Mariposa in the south. Rocks associated with the Mother Lode Gold District are mainly steeply dipping (50° to 80° east) and consist of Paleozoic and Mesozoic slates, schists, greenstones and serpentine. Serpentinized ultramafic rocks occur exclusively as elongate bodies associated with the Melones Fault Zone.

FIGURE 7.1

GEOLOGICAL SETTING OF THE FREMONT PROPERTY

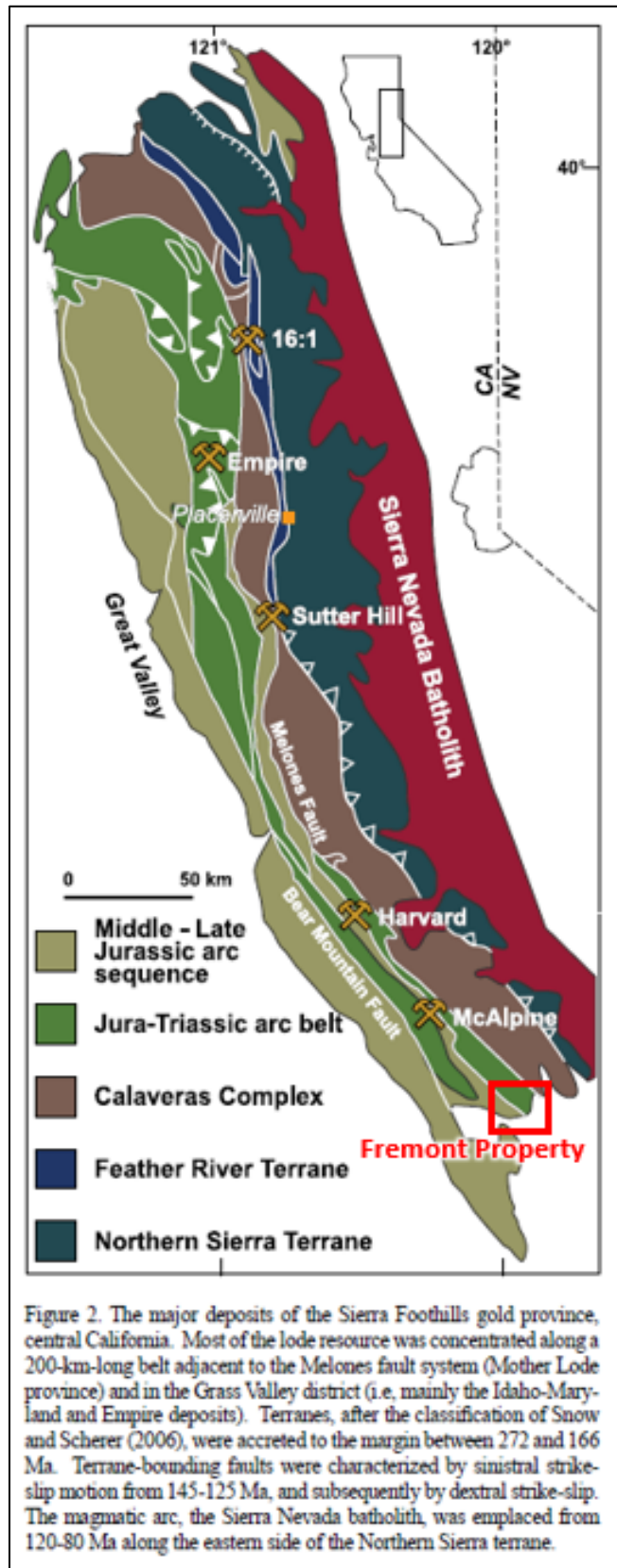

Source: modified by P&E (August 2022) after Goldfarb et al. (2008)

FIGURE 7.2 GOLD DISTRICTS OF THE SIERRA FOOTHILLS METAMORPHIC BELT, CALIFORNIA

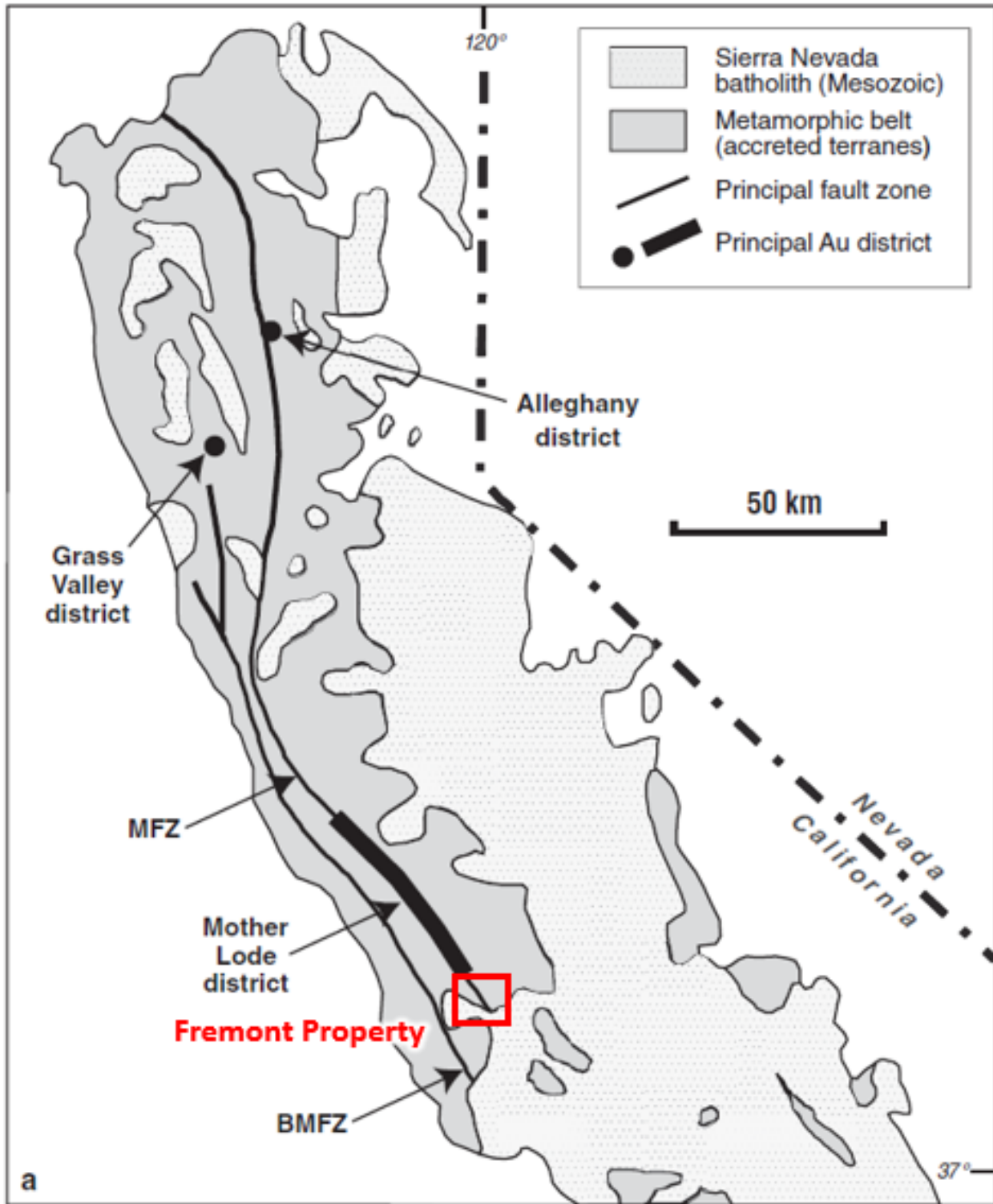

Source: modified by P&E (July 2022) after Sillitoe (2008)

7.3 PROPERTY GEOLOGY

The geology of the Fremont Property is dominated by the Mariposa Formation metasedimentary and metavolcanic rocks to the west, the Melones Fault Zone in the centre, and the Bullion Mountain Formation metavolcanics and Briceburg Formation metasedimentary rocks and metavolcanics to the east (Figure 7.3).

Mariposa Formation metasedimentary and metavolcanic rocks of the Middle–Late Jurassic Arc Sequence occur west of the Melones Fault Zone. The metasedimentary rocks consist of thick to thin bedded, intercalated, grey to brown, slate, siltstone, sandstone, and rare limestone. This unit is the footwall unit to the Melones Fault Zone. Sedimentary structures are well preserved in fine-grained sandstone and siltstone west of, and distal to the Melones Fault Zone. Sedimentary structures comprise load structures, normally graded bedding, ripple foresets and climbing ripples, which are indicative of submarine overbank deposits. Way-up indicators uniformly indicate that beds are the right way-up. The southwest corner of the Property contains meta-andesite and metabasalt flows of the Mariposa Formation.

Within approximately 200 m of the contact between the metasedimentary rocks and the Melones Fault Zone, the rocks become highly strained. Approaching the contact from the west: slate becomes increasingly common with rare, <10 cm thick layers of strongly boudinaged and sheared limestone; alteration intensity increases with proximity to the contact; and rock oxidation and chlorite alteration increase markedly within 50 m of the contact, with local stockwork areas of increased deformation, alteration, and quartz veining (SRK, 2014). This stockwork area hosts gold mineralization.

The Melones Fault Zone is a sequence of ultramafic rocks and an associated tectonic *mélange* that trends north-northwest and dips 45° to 60° east. Distally from the gold deposits the ultramafic rocks include fine-grained, very strongly sheared serpentinite with volumetrically insignificant asbestiform minerals observed in unaltered serpentinite outcrops as minor thin fracture fillings at the far northern end of the Property adjacent to the Merced River. These occurrences are situated far outside the hydrothermally altered mineralized zones that comprise the lode gold deposits and host rocks. Pervasive hydrothermal carbonate and sericite alteration that facilitated lode gold mineralization also replaced and obliterated all primary pyroxene and amphibole mafic minerals in all of the host rocks. The mineralizing fluids have thoroughly metasomatized enormous volumes of rock surrounding these deposits. There is a high level of confidence that no asbestiform minerals will be found in the Pine Tree/Josephine or Queen Specimen mineralized zones (Payne, 2014). Within the sheared serpentinite are sporadic tectonic emplaced blocks of more competent rock. These blocks consist of coarse-grained ultramafic rocks (likely peridotite), fragmental andesite, tuff and rare sedimentary rocks that are highly silicified. The sheared ultramafic rocks and the tectonic blocks are considered to represent a tectonic *mélange* developed during the evolution of the Melones Fault Zone and obduction of ophiolitic rocks (SRK, 2014). The sheared serpentinite and tectonic horses host quartz veins 2 m to >10 m thick. These veins are typically massive, sugary quartz veins that dip moderately east, with local breccia fragments, and host gold mineralization. The Melones Fault Zone hosts four gold mineralized areas, which from south to north are: the Chicken Gulch, Pine Tree–Josephine, Crown Point and Queen Specimen Deposits.

The Briceburg and Bullion Mountain Formations of the Jura-Triassic arc belt occur east of the Melones Fault Zone (Figure 7.3). These Formations are the hanging wall to the Melones Fault

Zone. The Briceburg Formation consists of thin to thick bedded sandstone, slate, interbedded tuff and rare chert. The rocks of this Formation generally strike southeast and dip steeply to moderately. Proximal to the Melones Fault Zone, this unit dips subvertical to steeply northeast and is transposed and very highly strained. Towards the northeast of the Fremont Property, the sedimentary and volcanoclastic rocks are intercalated with numerous, approximately five cm-wide chert layers. The Bullion Mountain Formation metavolcanics contain intermediate to mafic metavolcanic rocks with local pillow basalt, gabbro dykes and tuffaceous rocks.

FIGURE 7.3 FREMONT PROPERTY GEOLOGY

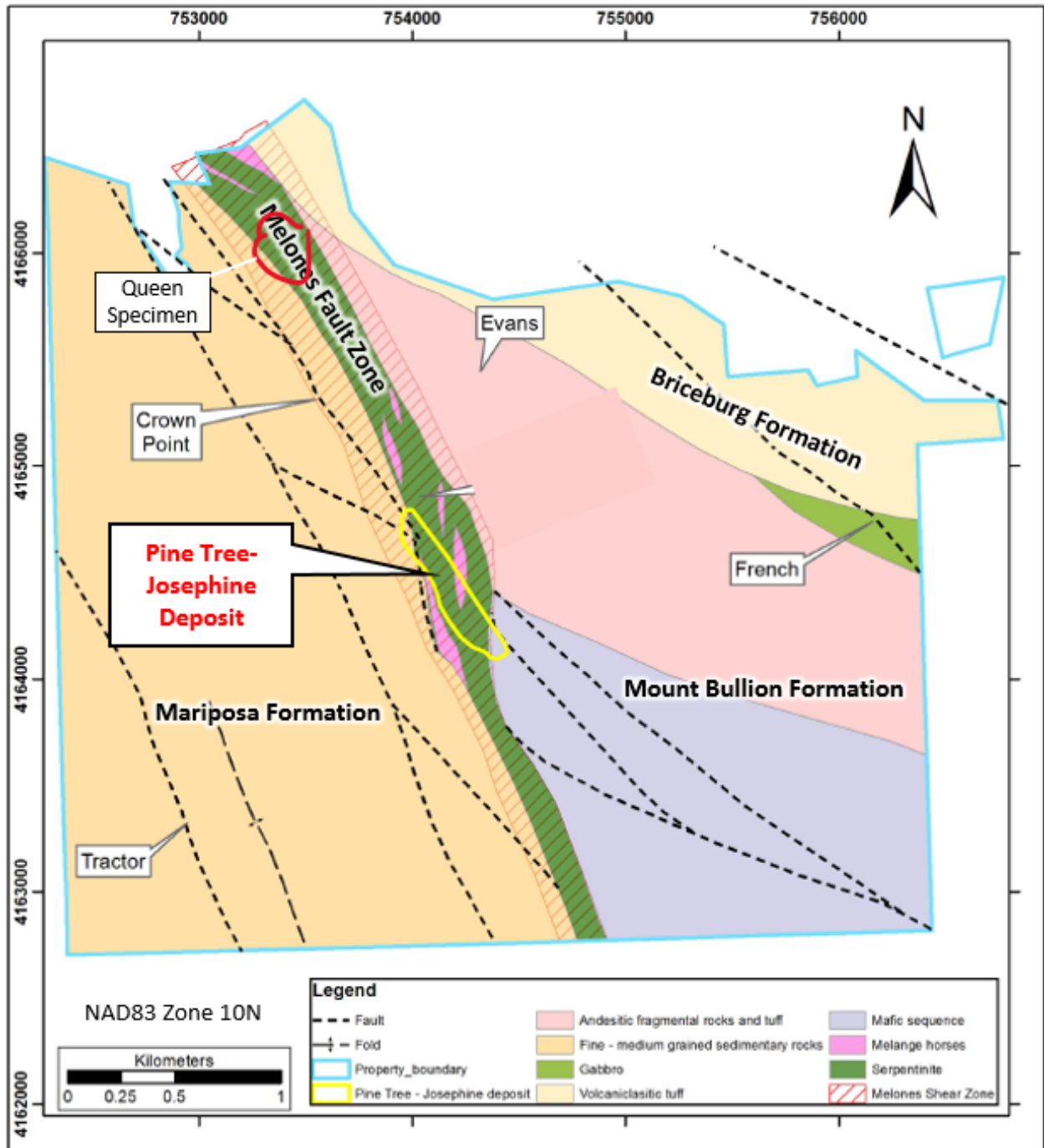

Sources: Modified by P&E (2022) after SRK (2014).

7.4 STRUCTURAL GEOLOGY

The following summary of the structural geology of the Fremont Property is an excerpt from SLR (2021), which relied heavily on the analysis of airborne geophysical data by SRK (2014) (Figures 7.4 to 7.7). Note that the comments below in square brackets are added for clarity and illustration by the Authors of this current Report.

“The brittle-ductile Melones Fault Zone is the principal structural element within the Fremont Property and trends north-northwest and dips 45° to 60° to the east [Figures 7.5 to 7.7]. In addition to the Melones Fault Zone, numerous faults and minor brittle-ductile shear zones exist. The Melones Fault Zone is an envelope of strongly deformed rocks with numerous, discrete, subsidiary shear zones, that is cored by sheared ultramafic, serpentinized rocks and extends well into the footwall sedimentary sequence and, to a lesser extent, into the hanging wall rocks. The Fault Zone varies in width along on its length and appears to pinch out towards the south of the study area and dilate to the north. The dilation to the north is principally due to the presence of a right-stepping jog in the Fault Zone; however, wider areas of Fault Zone may be in part related to the location of fold hinges within the Fault Zone (SRK, 2014).

Within the core of the Melones shear zone, rotated quartz porphyroclasts within the Mariposa Formation, combined with the shallow plunge of quartz veins boudins and F1 fold axes indicate D1 deformation was dominated by reverse dip-slip (hanging wall up and to the west) movement. However, within the sheared, serpentinized, ultramafic rocks, C-S fabrics are commonly well developed, and indicate dextral strike-slip, sporadically sinistral strike-slip, and reverse dip-slip kinematics (SRK, 2014).

Evidence for D1 reverse dip-slip movement is preferentially preserved in sedimentary and volcanoclastic sequences within the footwall and hanging wall margins of the shear zone, [whereas] evidence for D2 dextral strike-slip movement is preserved within ultramafic rocks in the core of the shear zone. It is possible that anisotropy between the relatively stronger sedimentary units, and the weaker, serpentinized ultramafic rocks allowed for the preferential preservation of D1 reverse movement within the sedimentary package, while D2 strike-slip deformation was partitioned into the serpentinized ultramafic rocks and evidence of the D1 reverse phase of deformation was destroyed during D2 strike-slip movement (SRK, 2014).

Late brittle faults [D3] were identified through the analysis of the geophysical data. They are regularly spaced (300 m to 500 m), typically west-northwest to west-trending faults [Figures 7.5 to 7.7]. These late faults typically offset and rarely truncate early brittle-ductile structures. West-northwest-trending brittle faults typically show dextral strike separation, whereas rare west-southwest to southwest-trending brittle faults show a sinistral strike separation. It is suggested that these late brittle faults may have formed as a conjugate pair in an overall strike slip regime with the σ_1 principal stress oriented approximately northwest to southeast (SRK, 2014).”

FIGURE 7.4 **MAGNETIC CALCULATED VERTICAL DERIVATIVE MAP FROM THE 2015 AIRBORNE GEOPHYSICAL SURVEY**

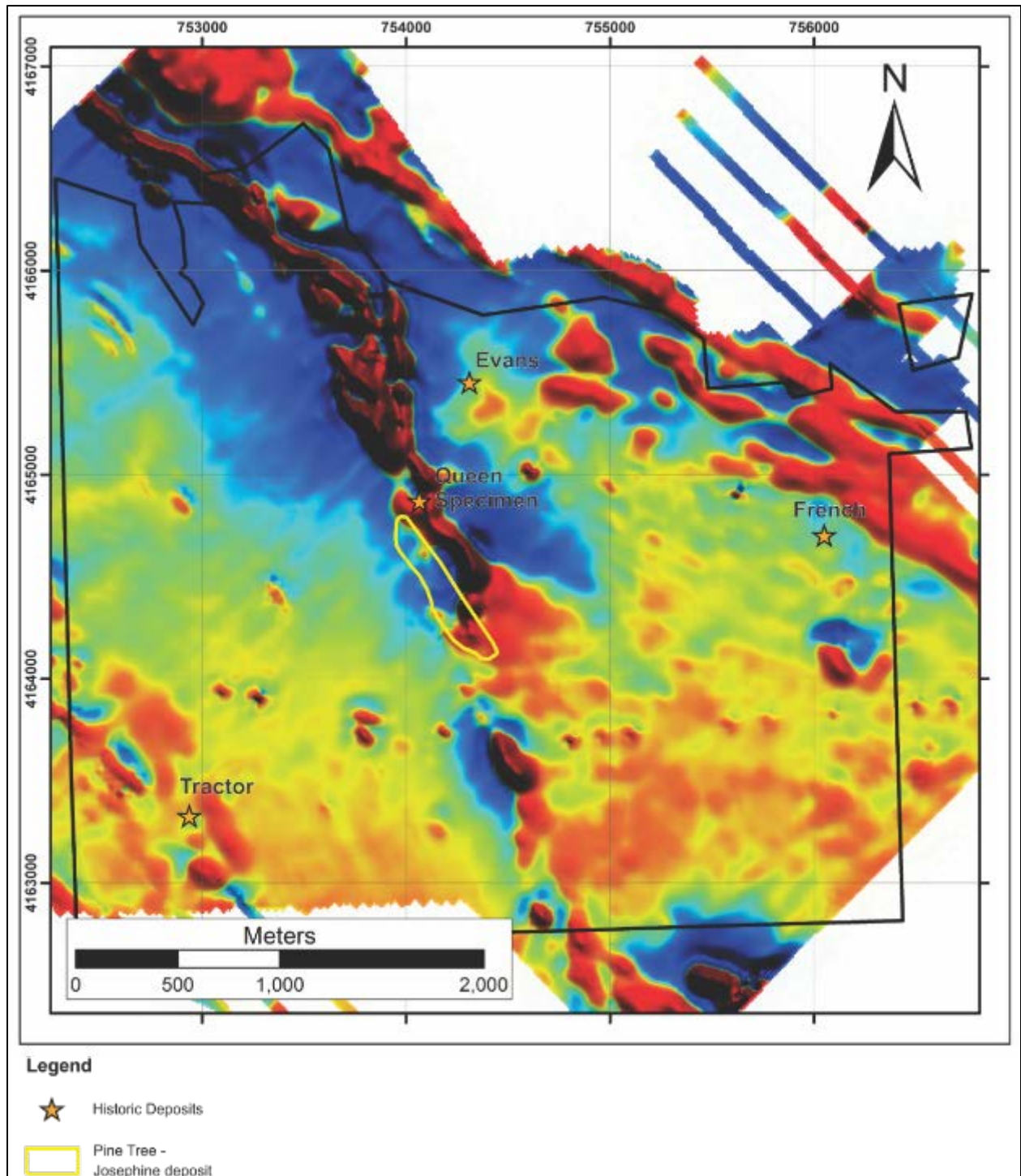

Source: SRK (2015)

FIGURE 7.5 SRK STRUCTURAL INTERPRETATION OF MAGNETIC FIRST VERTICAL DERIVATIVE

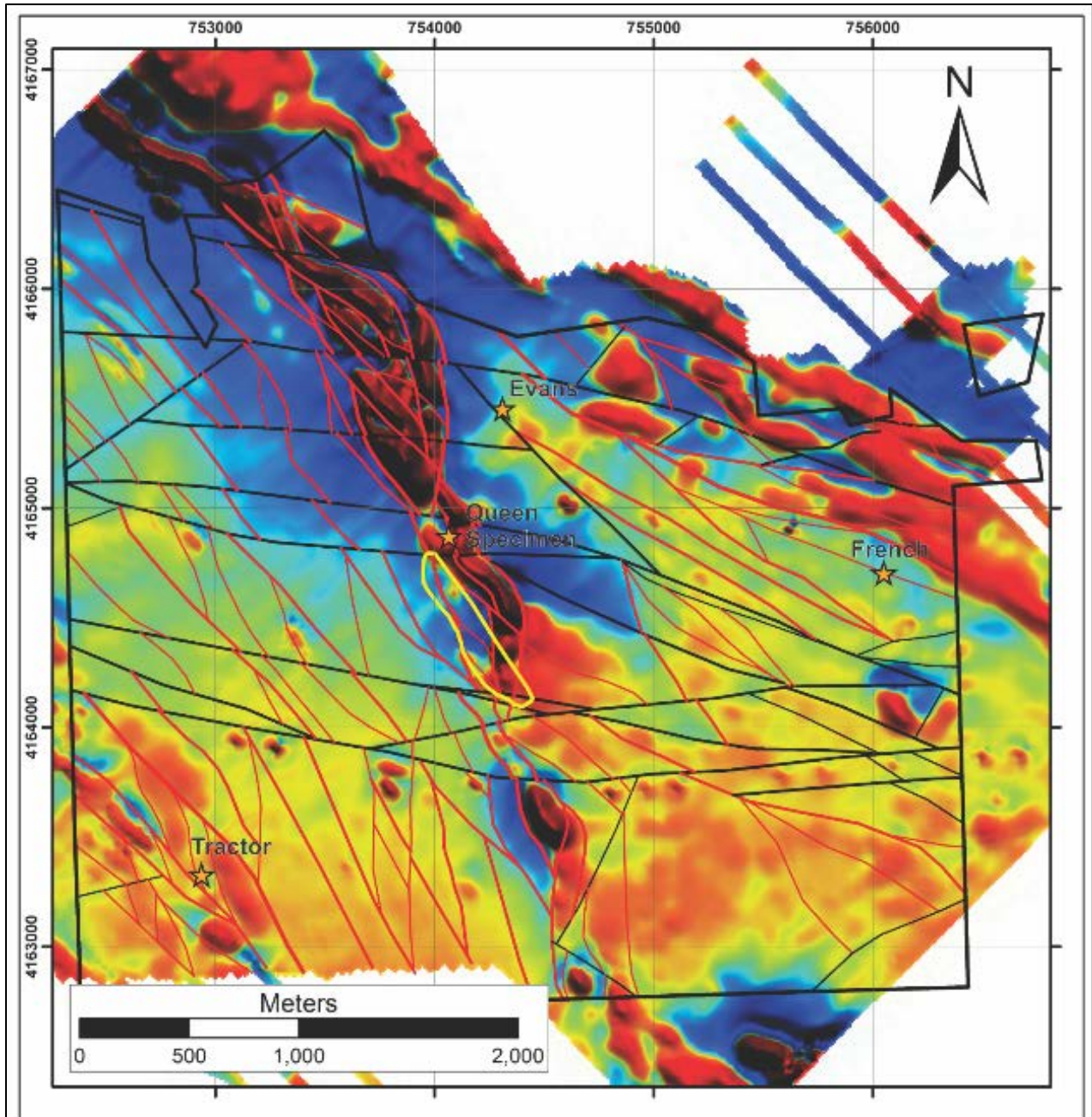

Legend

Faults

- | | | |
|----------------------------------|-----------|-------------------------------|
| D ₁ to D ₃ | 1st Order | Historic Deposits |
| | 2nd Order | |
| | 3rd Order | |
| D ₂ | 1st Order | Pine Tree - Josephine deposit |
| | 2nd Order | |

Source: SRK (2015)

FIGURE 7.6 SRK MAP ILLUSTRATING DILATIONAL JOG AND FOLDING INTERPRETATION AT QUEEN SPECIMEN DEPOSIT AREA

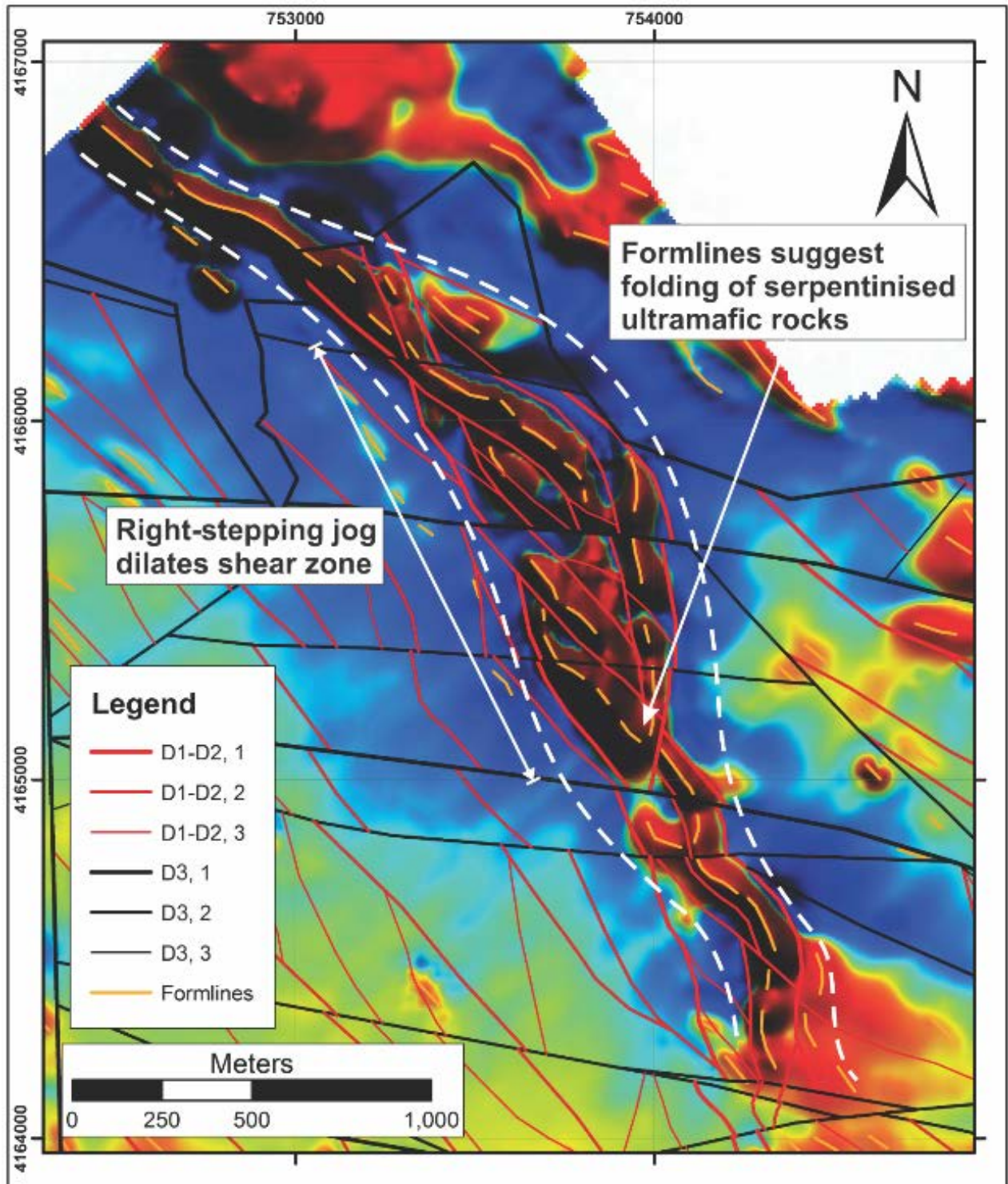

Source: SRK (2015)

FIGURE 7.7 SRK STRUCTURAL AND LITHOLOGY INTERPRETATION

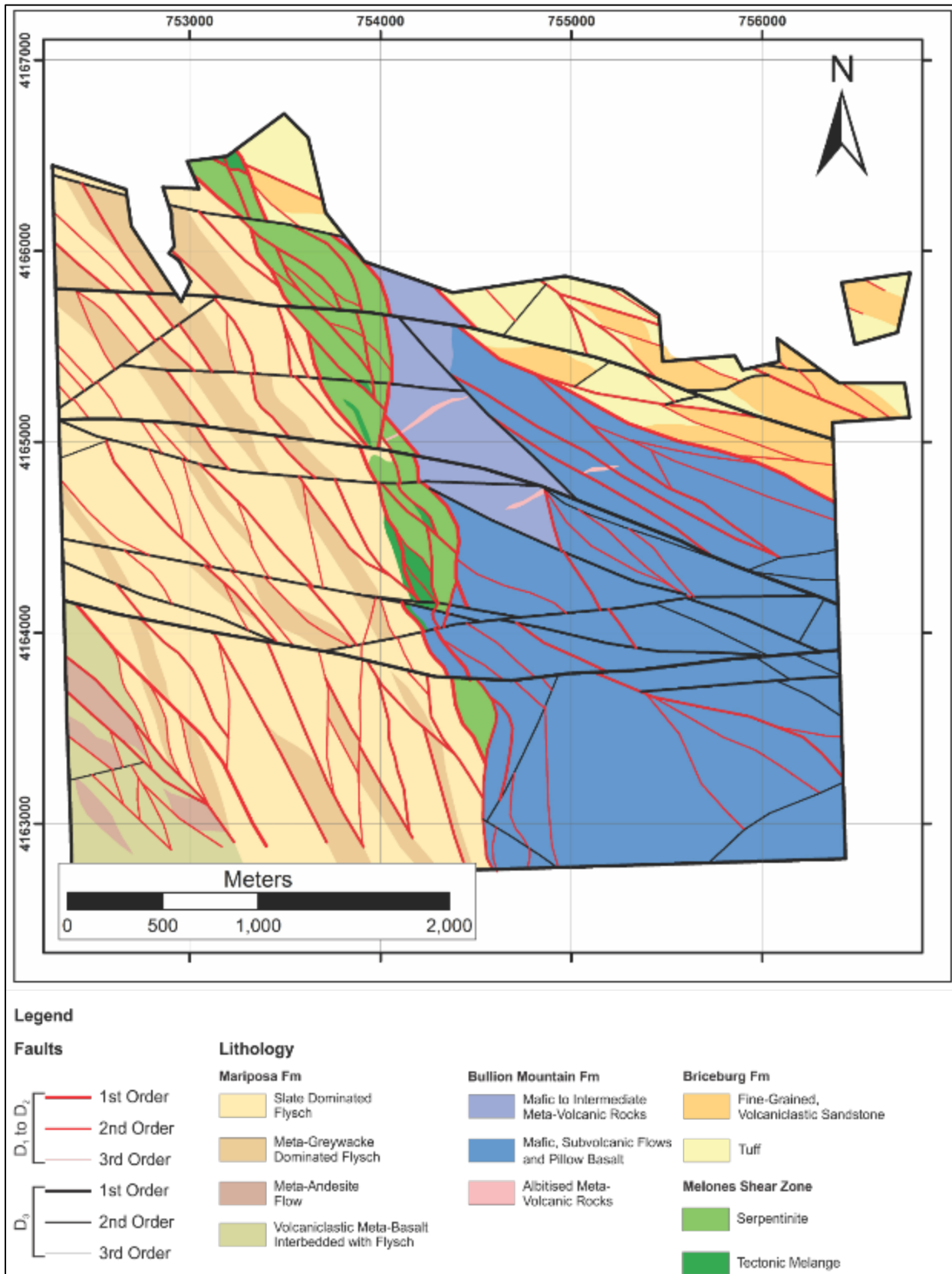

Source: SRK (2015)

7.5 DEPOSIT GEOLOGY

Four gold deposits on the Fremont Property are described. Two of the four deposits, namely the Pine Tree-Josephine and Queen Specimen (Figure 7.8), are included in the current Mineral Resource Estimate described in Section 14 of this Report and are therefore described below. The additional two deposits, Crown Pillar and Chicken Gulch, are not included in the current Mineral Resource Estimate. However, with additional drilling, they could potentially be included in a future updated Mineral Resource Estimate, and therefore are described farther below.

FIGURE 7.8 MINERALIZED ZONE AREAS

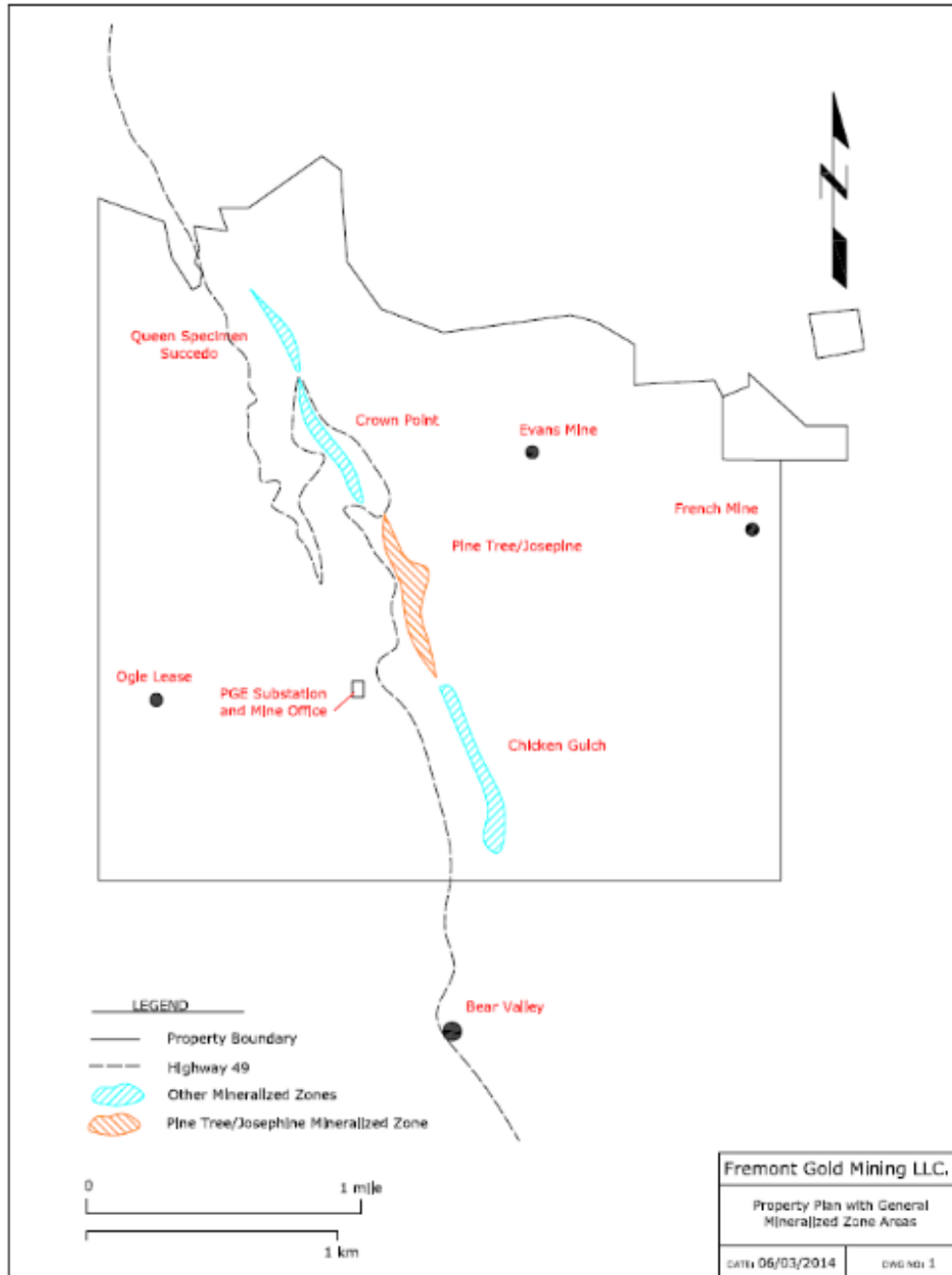

Source: Inspectorate (2014)

7.5.1 Pine Tree-Josephine Deposit

Pine Tree-Josephine is the most significant of the four gold mineralized deposits on the Fremont Property. The Pine Tree-Josephine Deposit has a strike length of 823 m (2,700 ft), dips moderately to steeply east-northeast, and has a maximum width of 152 m (500 ft) on surface. Historically, this Deposit has been extensively developed by numerous shafts and drifts and produced >125,000 oz gold, primarily from shrinkage and open stope mining, until mine closure in 1944. Most of the mine development took place in a zone approximately 61 m (200 ft) wide, bounded on the hanging wall side by the Josephine Vein.

The Pine Tree-Josephine Deposit is hosted mainly in a fault *mélange* that consists of highly altered meta-sedimentary rocks, metavolcanics and ultramafic rocks, in which much of the pre-existing lithologies have been replaced by quartz, ankerite and sulphides. Gold mineralization does extend locally into the footwall Mariposa Formation and into the hanging wall carbonate-altered serpentinites and altered gabbros/diorites. However, the more significant values are found within the footwall Pine Tree Vein, the hanging wall Josephine Vein and the inter-vein material, which is 46 m to 61 m (150 ft to 200 ft) thick.

Gold mineralization in the Pine Tree-Josephine Deposit occurs mainly as free grains interstitial to vein quartz or intergrown with pyrite. The upper portion of the Deposit is oxidized.

7.5.2 Queen Specimen Deposit

The Queen Specimen Deposit is the most northerly major alteration and mineralized zone known on the Fremont Property. The Deposit was originally developed by two separate sets of underground workings. The upper Queen Specimen workings were accessed by cross-cut adits from the hanging wall, whereas the lower Succedo workings consist of a 152 m (500 ft) internal shaft with levels developed from the River Tunnel.

On surface, the Queen Specimen Deposit consists of a number of sub-parallel quartz veins in quartz-ankerite altered serpentinite. The hanging wall rocks are the Calaveras Formation of meta-sedimentary rocks and volcanics and the footwall rocks are the Mariposa Formation of metamorphosed slates and greywacke.

Drilling during the 1985-1986 campaign was limited to eight inclined RC holes over a strike length of 213 m (700 ft) and to a maximum depth of 107 m (350 ft). The drilling defined a similar style of mineralization to that of the Pine Tree-Josephine Deposit, with generally similar grades, and overall narrower widths. The Queen Specimen Deposit dips 55° to 60° east.

Similar to the Pine Tree-Josephine Deposit, most of the mineralization in the Queen Specimen Deposit is free gold in the quartz veins, gold associated with pyrite the sulphide zone, and gold in the oxide cap.

7.6 MINERALIZATION

Three main styles of gold mineralization are present at the Pine Tree-Josephine Deposit and generally throughout the 4 km mineralized trend: 1) quartz hosted; 2) sulphide replacement; and

3) oxide cap mineralization (Figure 7.9). Each of these three styles of mineralization are briefly described below.

FIGURE 7.9 REPRESENTATIVE INTERPRETIVE VERTICAL CROSS SECTION OF THE PINE TREE-JOSEPHINE GOLD DEPOSIT

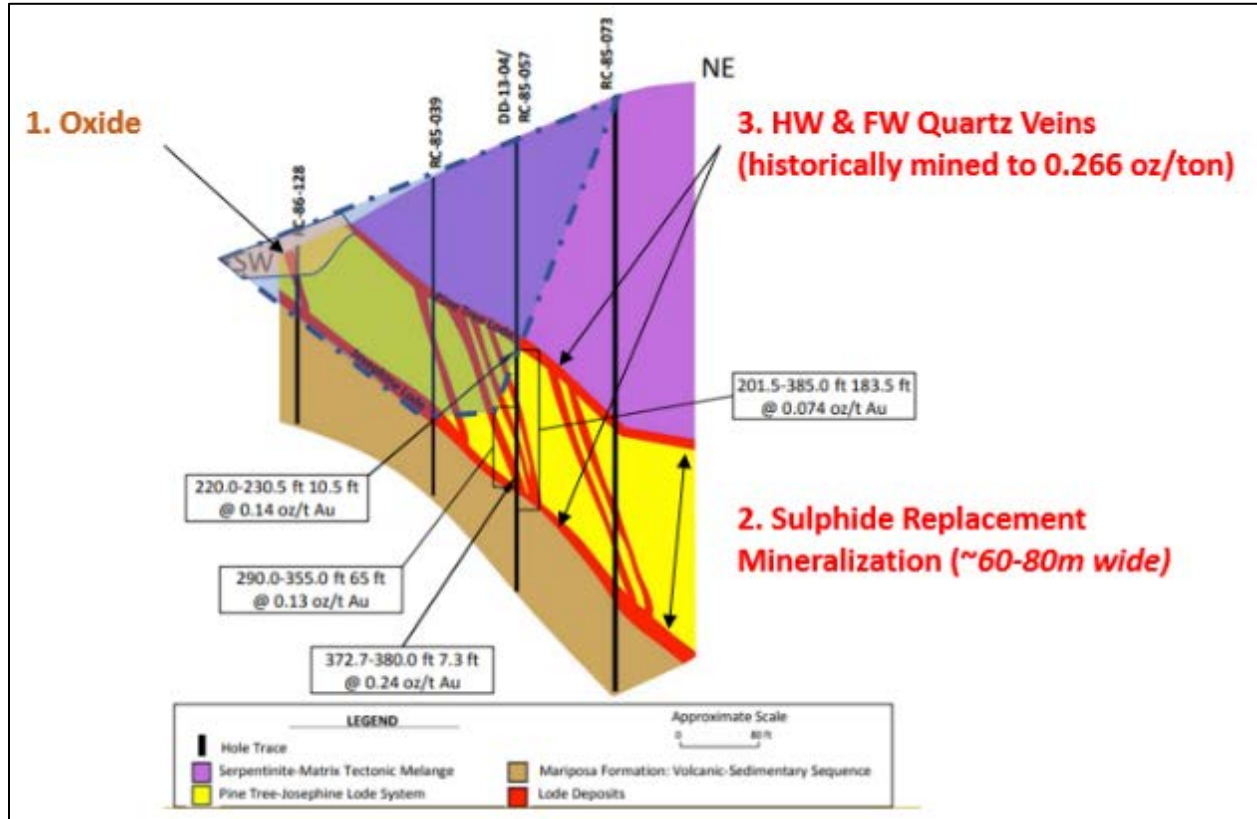

Source: Stratabound (April 2022)

The quartz-hosted mineralization, represented primarily by the footwall and hanging wall veins and stockwork vein arrays locally in the footwall and hanging wall, consists primarily of free gold in quartz (Figure 7.10). In historical mining (SLR, 2021), higher-grades were present in large quartz veins where cut by late-stage quartz veins, defining mineralized shoots. The mineralized shoots were generally short in strike length, and persistent at depth.

The sulphide replacement mineralization occurs mainly in the tectonic melange between the footwall and hanging wall veins. According to SLR (2021), the host meta-sedimentary, volcanic and ultramafic rocks are intensely altered to ankerite, sericite, albite, quartz, mariposite, and 3% to 4% pyrite ± arsenopyrite ± chalcopyrite. Gold occurs intergrown with the pyrite and interstitial to the quartz. Mineralized schists and tectonite pods contain pyrite and ankerite and host quartz-ankerite veinlets.

According to Burgoyne (2013), historical petrographic thin-section studies report the presence of gold mineralogically as native gold and electrum. Gold grains within pyrite grains vary from 0.03 mm to 0.05 mm in size.

FIGURE 7.10 **VISIBLE GOLD IN QUEEN SPECIMEN 2018 DRILL HOLE QS-DD-18-014**



Source: California Gold (press release May 2, 2018).

Description: Visible gold circled red.

The oxide gold mineralization occurs as a thin cap on the upper portions of the gold deposits. In the order of one-sixth to one-seventh of the upper parts of the deposits are variably oxidized and potentially amenable to cyanide heap leaching. Generally, the oxide zone varies from approximately 0.5 m to a maximum of 56 m (185 ft) below surface.

Structurally, the bulk of the gold mineralization along the 4 km Pine Tree-Josephine mineralized trend is interpreted to be associated with fault-fill veins, breccia veins, and extensional veins formed during various increments of D1 brittle-ductile reverse dip-slip movement (shearing) along the Melones Fault Zone (SRK, 2014).

7.7 OTHER GOLD DEPOSITS OF INTEREST

The Fremont Property gold deposits not included in the current Mineral Resource Estimates are the Chicken Gulch and Crown Point Deposits. These two deposits are both located along the 4 km Pine Tree-Josephine trend (Figure 7.11), however, there are insufficient drilling data to support Mineral Resource estimation. With further drilling, however, these two deposits could perhaps be included in future updated Mineral Resource Estimates, and therefore are briefly described below. (Note that in addition to the Chicken Gulch and Crown Point Deposits, two more, smaller, vein-type gold deposits known as the Evans and French Deposits are located to the east of the Pine Tree-Josephine Deposit - see Figure 7.8).

7.7.1 Chicken Gulch Deposit

The Chicken Gulch Deposit is a wedge-shaped, altered and mineralized zone that extends approximately 914 m (3,000 ft) in length and 107 m to 122 m (350 ft to 400 ft) in width at the south limit of the Fremont Property (see Figure 7.8). The Deposit narrows irregularly along trend towards the north and ultimately coalesces with Pine Tree-Josephine Deposit. Quartz veins occur along the hanging wall and footwall of the altered zone for much of its length. Historical development consisted only of surface cuts, some shallow shafts, and an adit driven from the north bank of Chicken Gulch. Near-surface gold mineralization occurs in the oxide zone and deeper mineralization in the underlying sulphide zone.

FIGURE 7.11 PINE TREE-JOSEPHINE GOLD MINERALIZED TREND

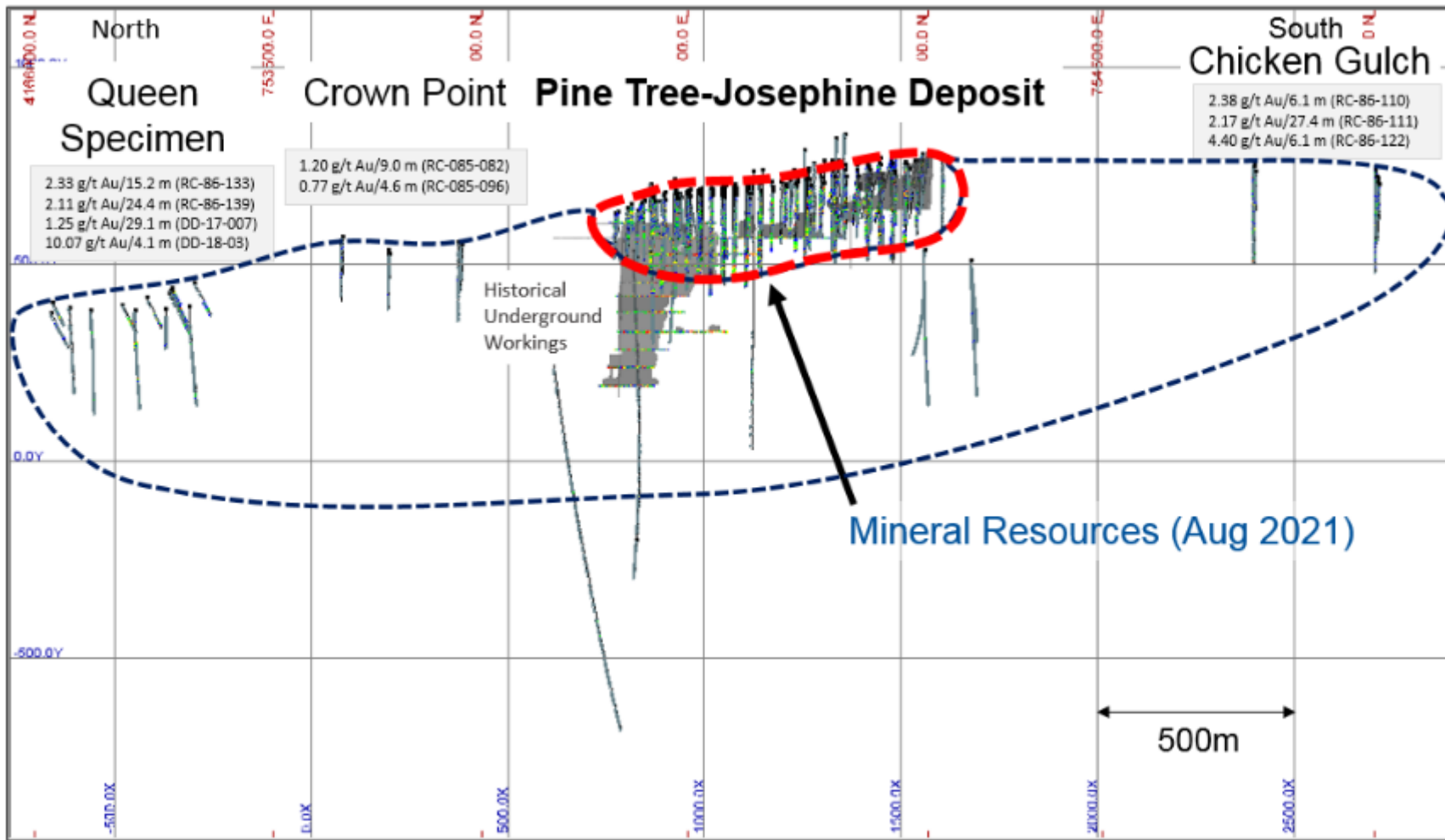

Source: Stratabound (April 2022)

7.7.2 Crown Point Deposit

The Crown Point Deposit is located north along strike from the Pine Tree-Josephine Deposit (see Figure 7.8). The Crown Point Deposit was explored by a number of short adits, most of which are now collapsed. Crown Point is geologically similar to the Pine Tree-Josephine and Chicken Gulch Deposits, with serpentinite and Mariposa Formation rocks in the hanging wall.

According to SRK (2014), an approximately 10 m-wide shear zone within the sedimentary sequence at Crown Point defines the footwall margin of the Melones Fault Zone in this area (Figure 7.12A). This shear zone is oriented at $020^{\circ}/52^{\circ}$, and contains a stretching lineation oriented at $35^{\circ}/071^{\circ}$. Shear sense indicators here indicate dextral-reverse oblique-slip movement. The Crown Point Shear Zone is characterized by four features: 1) a hanging wall quartz vein stockwork in thick bedded, medium-grained sandstone; 2) a 1 m-wide zone of strong chlorite alteration at the hanging wall margin; 3) shear zone parallel quartz veins within fine-grained sedimentary rocks in the core of the shear zone; and 4) a 50 cm-wide quartz vein breccia at the footwall margin (Figure 7.12B). Significant quartz vein development was not observed in the footwall rocks to the Crown Point Shear Zone.

FIGURE 7.12 CROWN POINT PROSPECT SHEAR ZONE

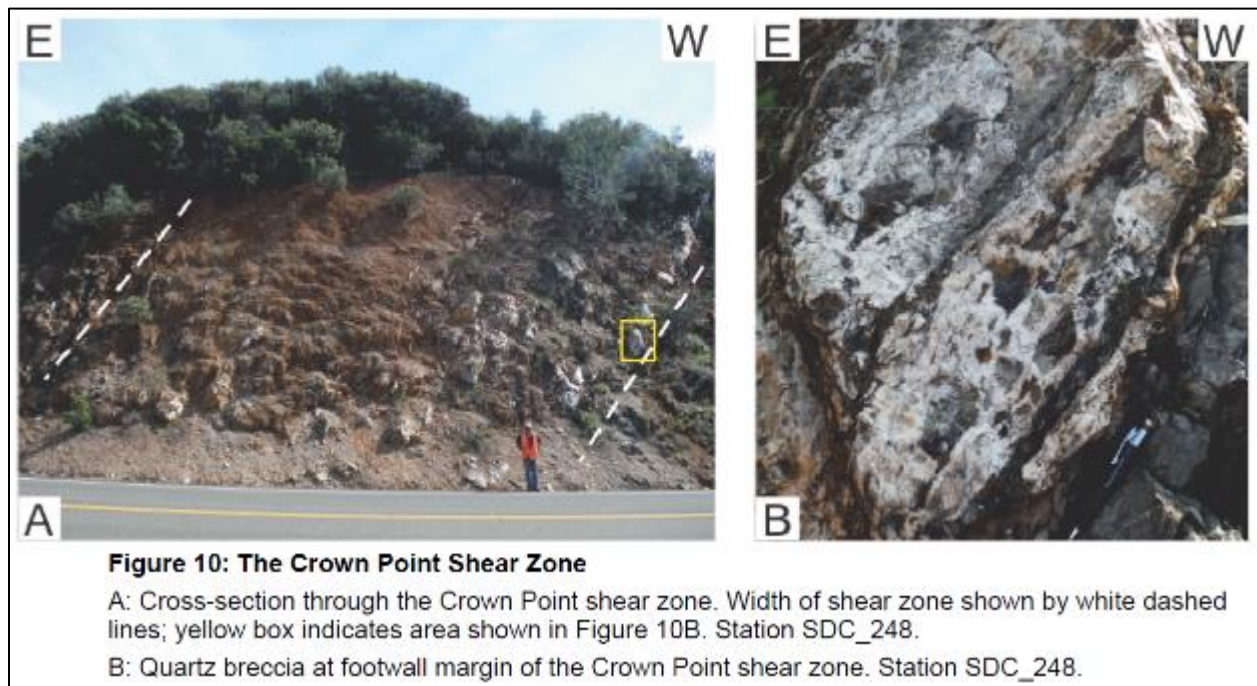

Source: SRK (2014)

8.0 DEPOSIT TYPES

The gold deposits of the Fremont Property are classified as orogenic mesothermal gold deposits (Sillitoe, 2008; Goldfarb and Groves, 2015; Groves and Santosh, 2016). This gold deposit type is hosted in metamorphosed volcanic and sedimentary rocks and associated with major terrane-bounding fault zones in subduction-related geodynamic and geotectonic settings (Figures 8.1 and 8.2).

Gold mineralization in orogenic gold deposits is structurally controlled and hosted in altered quartz veins, vein networks, and wall rock adjacent to and along major regional-scale faults (Figure 8.3). The veins consist mainly of quartz and carbonate, with smaller amounts of chlorite, scheelite, tourmaline, and native gold. Pyrite, chalcopyrite and pyrrhotite comprise <10% of the veins. Mineralization is generally gold-rich with a gold to silver ratio of 5:1 to 10:1 and high contents of sulphur, arsenic, tellurium, tungsten, boron and molybdenum are present, along with low contents of lead and zinc.

Vein strike and dip extents range from hundreds to thousands of metres, either singly or, more typically, in complex vein networks. Veins are hosted in a wide variety of volcanic, sedimentary, intrusive and metamorphic rock types. The veins generally occur as systems of parallel or acutely intersecting veins, ranging in dip from 25° to 60°. Gold mineralization occurs as shoots that are generally found in ribboned vein structures, commonly in the hanging wall and (or) footwall of barren or low grade “bull” quartz veins.

Despite their significant vertical depth extent (commonly >1 km), the gold deposits lack clear vertical mineral zonation. Wall rock alteration haloes are zoned and consist of carbonatization, sericitization, and pyritization-associated alteration mineral assemblages. Halo dimensions vary with the composition of the host lithologies and may envelope entire deposits in mafic and ultramafic rocks.

Spatial relationships of the Mother Lode Gold Belt along the Melones Fault Zone appear to indicate that the mineralizing fluids utilized the crustal scale fault system as a means of fluid transit during the Early Cretaceous (Goldfarb *et al.*, 2008). In this model, strike-slip reactivation of the Melones Fault Zone channelled ascent of deeply-sourced fluids that led to the gold mineralization.

FIGURE 8.1 GEODYNAMIC SETTING OF OROGENIC GOLD MINERALIZATION

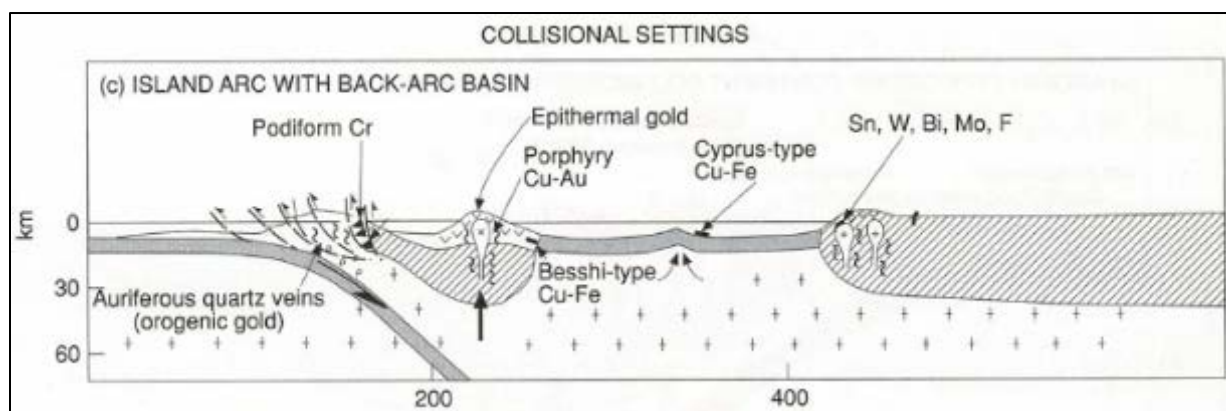

Source: Robb (2005)

FIGURE 8.2 TECTONIC ENVIRONMENT OF OROGENIC GOLD MINERALIZATION IN CALIFORNIA

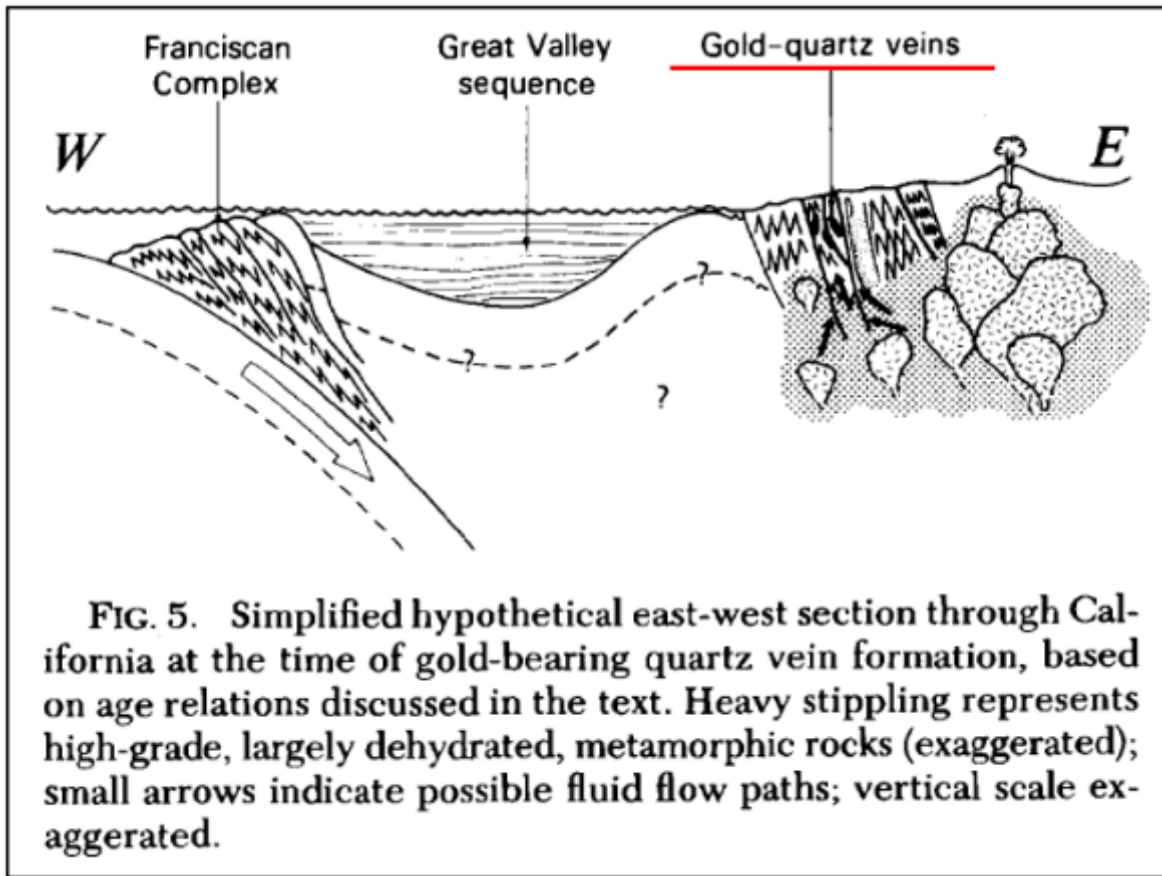
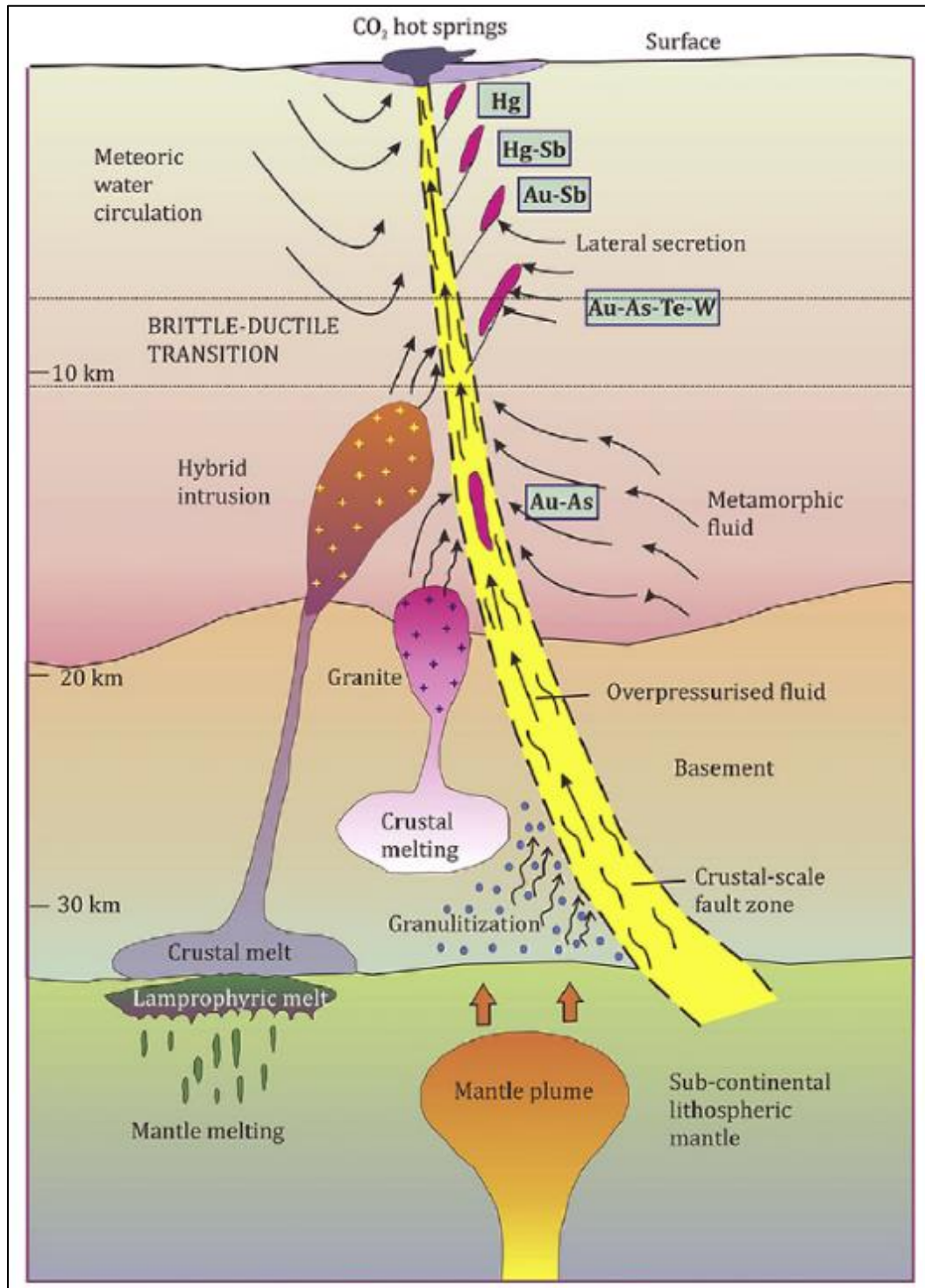

FIG. 5. Simplified hypothetical east-west section through California at the time of gold-bearing quartz vein formation, based on age relations discussed in the text. Heavy stippling represents high-grade, largely dehydrated, metamorphic rocks (exaggerated); small arrows indicate possible fluid flow paths; vertical scale exaggerated.

Source: Bohlke and Kistler (1986)

FIGURE 8.3 FAULT-CONTROL MODEL FOR OROGENIC GOLD MINERALIZATION



Source: Groves and Santosh (2016)

Description: Schematic model for orogenic fluid sources and gold mineralization in the crust. From meteoric water circulation and lateral secretion, magmatic-hydrothermal fluid exsolution from various granite intrusion types, to granulitization and prograde metamorphic devolatilization processes during orogeny. The gold-bearing fluids ascend along crustal-scale faults (e.g., San Andreas Fault) and become trapped in splays (Melones Fault Zone), where they cool, mix with surface-derived fluids (i.e., meteoric waters) and react with wall rocks to form gold deposits.

9.0 EXPLORATION

Further to the historical exploration programs outlined previously in Section 6, Stratabound completed surface exploration activities on the Fremont Property in 2022. The exploration activities included compilation and reporting of a 2016-2017 property-wide soil geochemistry survey, in addition to trenching, mine development activities and flying a LiDAR™ survey in 2022. These activities are outlined below from Stratabound press releases dated February 22, 2022 and March 23, 2022, which are available on its website (www.stratabound.com) and filed under the Company profile on SEDAR (www.sedar.com).

9.1 SOIL GEOCHEMISTRY SURVEY

The soil geochemistry survey covered the entire Fremont Property with 1,364 samples, including 51 field duplicate samples collected on a 100 m x100 m grid (Stratabound press release dated February 23, 2022). The soil samples were collected in canvas sacks by qualified independent contract exploration personnel at UTM grid coordinates provided. Hand-held Garmin GPS units were utilized to locate and record the actual sample sites. The survey was completed by California Gold in two tranches: the first in October 2016 and the second in February 2017 (Pohlman, 2016, 2017). However, the results of these two surveys were not previously compiled and reported. The results are summarized in Appendix J.

Based on their compilation, Stratabound reported a large gold-in-soil anomaly extending across the entire 4 km Property length and averaging 285 m wide. Offset by an interpreted fault, the property-wide soil geochemical survey defines nearly continuous gold-in-soil mineralization of >30 ppb (parts per billion) up to 112,491 ppb gold, (112.5 g/t or 3.281 ounces per ton Au) covering an area of 1.14 km² (282 acres). Excluding the highest value, the remaining 102 samples within the anomaly range up to 5,210 ppb and average 412 ppb gold, a multiple of 61.5 times above the average background value of 6.7 ppb gold outside the anomaly. The excluded high value is located within 15 m of the historically mined, high-grade Josephine Lode Gold Vein where it outcrops at surface and may be reflective of mineralization related to it. Results of the survey are presented in Figure 9.1.

The surface gold-in-soil anomaly encompasses and links the three historical producing gold deposits, the Pine Tree, Josephine and Queen Specimen Mines, plus the undeveloped Crown Point and Chicken Gulch Zones. Although hosted in the same geological setting featuring similar gold mineralization, the four deposits and zones previously remained materially unconnected, due to the lack of intervening drill assay information prior to this soil geochemical survey.

In addition, a high-grade, >200 ppb gold-in-soil core area within the larger geochemical anomaly defined by 31 soil samples averaging 1,097 ppb gold (1.097 g/t Au), excluding the high value sample, lies also in an oxidized surface cap zone.

FIGURE 9.1 FREMONT PROPERTY GOLD IN SOIL ANOMALIES

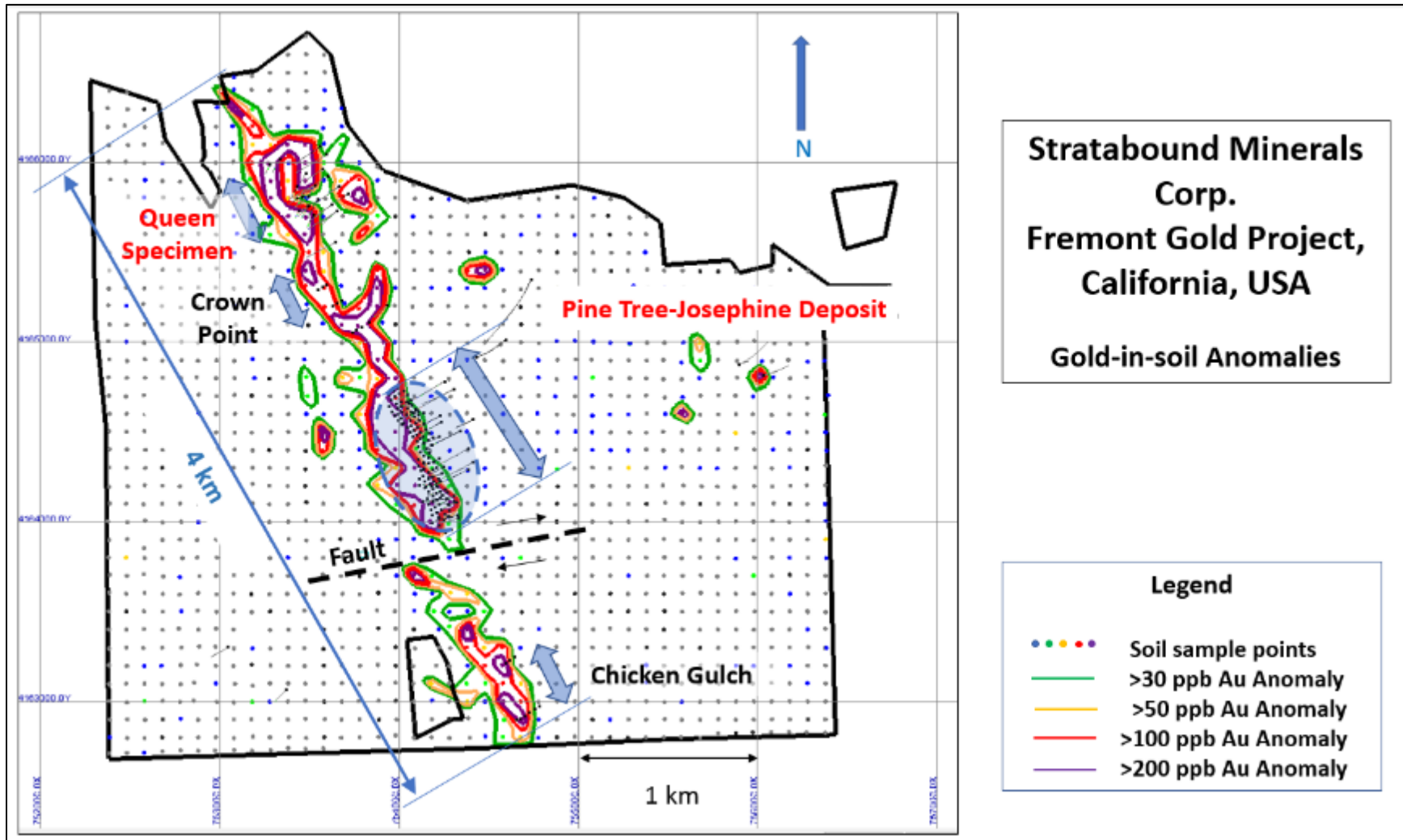

Source: Stratabound (June 2022)

Note: 1 ppb Au = 0.001 g/t Au.

9.2 SURFACE TRENCHING

The exploration work included excavation of eight surface trenches at 50 m intervals across 500 m of strike length overlying the Queen Specimen Deposit. The Queen Specimen Deposit is the northernmost of four separately drilled gold-mineralized zones that connected along four km of strike on surface by a >30 ppb gold in-soil anomaly (see Figure 9.1).

Systematic mapping and sampling of the new Queen Specimen trenches were designed to define the at-surface gold mineralization projected from historical and recent diamond and RC drill holes extending from 300 m below surface. The trenches range in length from 35.1 m to 93.0 m, most trend north-northeast to northeast, and one (the southernmost – Trench 6) trends southeast (Table 9.1 and Figure 9.2). The geological mapping results correlate well with the underlying geology. In total, 334 trench samples were taken for assay. The gold assay results range from 0.005 g/t up to 4.140 g/t Au (Trench 1). The assay results are compiled in Appendix K.

Trench ID	Easting¹	Northing¹	Elevation (m)	Length (m)
QS-TR-22-001	753,262.90	4,166,000.00	406.16	93.00
QS-TR-22-002	753,271.16	4,165,890.46	422.87	35.10
QS-TR-22-003	753,293.51	4,165,786.20	459.37	89.90
QS-TR-22-004	753,334.59	4,165,737.67	468.39	29.30
QS-TR-22-005	753,276.78	4,165,808.80	452.95	64.00
QS-TR-22-006	753,364.40	4,165,720.00	467.05	71.60
QS-TR-22-008	753,267.84	4,165,834.32	445.17	59.00
QS-TR-22-009	753,232.40	4,165,898.20	433.80	76.20
Total				518.00

Source: Stratabound (June 2022)

Note: ¹ coordinates are in NAD83 Zone 10 UTM.

FIGURE 9.2 SURFACE TRENCHES AT QUEEN SPECIMEN

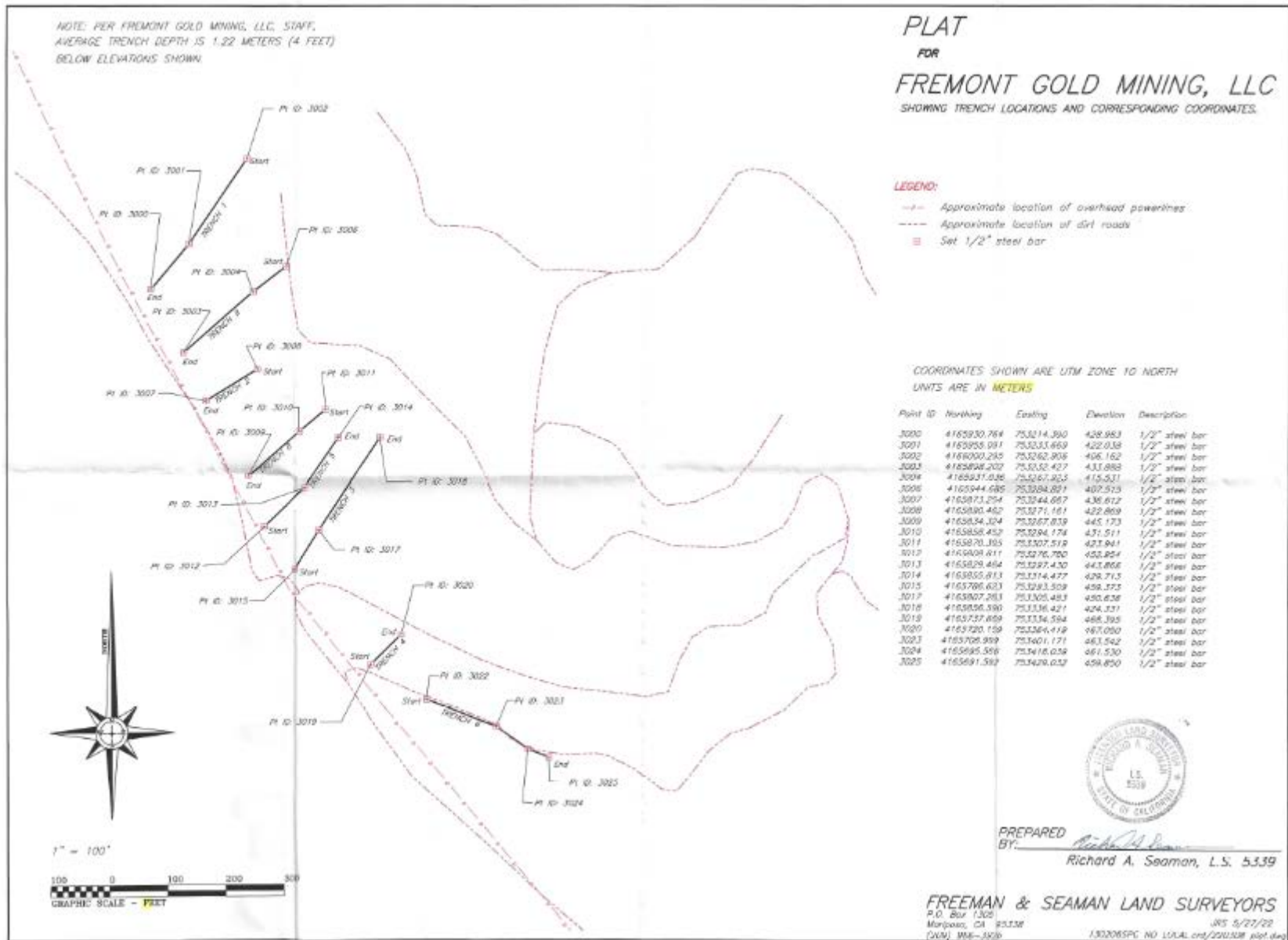

Source: Stratabound (June 2022)

9.3 DRILL ROAD CHANNEL SAMPLING

The information in this section is summarized from Campo (2022).

In May 2022, outcrop exposures along the Pine Tree-Josephine drill road system were systematically mapped and sampled, in order to further evaluate the oxide mineralization exposed in this Mineral Resource area. 14 sections (PTJ-SS-22-01 to PTJ-SS-22-14) of the road network that had mainly continuous outcrop exposure of strongly oxidized bedrock and regolith were channel sampled in 3 m (10 ft) increments. CRMs, blanks, and field duplicate samples were included at a 5% frequency each.

The samples were collected with a geopick and pan in the soft, deeply weathered exposures. Hammer and chisels were utilized in some of the hard outcrops. The start and end points of each sample were surveyed with a hand-held Garmin 64 GPS unit. All samples at the site of their collection were photographed.

Geologically, most of the samples are of altered, deeply weathered diorite and with mafic or serpentinite clasts. 16 samples were of greywacke and sandstone of the Mariposa Formation. Some of the outcrops included small zones of silicified and pyrite altered diorite.

In total, 127 samples were taken from the 14 channels. The channels and samples returning >0.5 g/t Au are shown in Figure 9.3 and listed in Table 9.2, respectively.

FIGURE 9.3 LOCATION OF PINE TREE-JOSEPHINE DRILL ROAD SAMPLES WITH >0.5 G/T AU



Source: Campo (2022)

Note: The long dimension of the photograph is approximately 500 m (1,600 ft).

TABLE 9.2
DRILL ROAD CHANNEL SAMPLING ASSAYS >0.5 G/T AU

Channel	Sample No.	From (ft)	To (ft)	Lithology	Au (g/t)
PTJ-SS-22-01	421758	10	20	diorite w/mafic or serp clasts	0.52
PTJ-SS-22-01	421759	20	30	diorite w/mafic or serp clasts	0.95
PTJ-SS-22-01	421760	30	40	diorite w/mafic or serp clasts	1.00
PTJ-SS-22-01	421762	74	87	diorite w/mafic or serp clasts	0.54
PTJ-SS-22-01	421765	125	135	diorite w/mafic or serp clasts	0.59
PTJ-SS-22-02	421772	0	10	diorite w/mafic or serp clasts	0.55
PTJ-SS-22-02	421773	10	20	diorite w/mafic or serp clasts	0.79
PTJ-SS-22-02	421774	20	30	diorite w/mafic or serp clasts	0.68
PTJ-SS-22-02	421775	30	40	diorite w/mafic or serp clasts	0.75
PTJ-SS-22-02	421779	60	70	diorite w/mafic or serp clasts	1.79
PTJ-SS-22-02	421780	70	80	diorite w/mafic or serp clasts	2.73
PTJ-SS-22-02	421782	80	90	diorite w/mafic or serp clasts	2.76
PTJ-SS-22-02	421783	90	100	diorite w/mafic or serp clasts	2.83
PTJ-SS-22-02	421784	100	110	diorite w/mafic or serp clasts	1.22
PTJ-SS-22-02	421785	110	120	diorite w/mafic or serp clasts	1.84
PTJ-SS-22-02	421787	120	130	diorite w/mafic or serp clasts	1.15
PTJ-SS-22-02	421788	130	140	diorite w/mafic or serp clasts	1.76
PTJ-SS-22-02	421789	140	150	diorite w/mafic or serp clasts	3.42
PTJ-SS-22-02	421790	150	160	diorite w/mafic or serp clasts	2.68
PTJ-SS-22-02	421791	160	170	diorite w/mafic or serp clasts	2.09
PTJ-SS-22-04	421819	40	50	diorite w/mafic or serp clasts	0.57
PTJ-SS-22-05	421821	10	20	diorite w/mafic or serp clasts	0.51
PTJ-SS-22-05	421823	30	40	diorite w/mafic or serp clasts	0.73
PTJ-SS-22-07	421848	40	50	limonitic greywacke and shale	1.03
PTJ-SS-22-07	421849	50	60	limonitic greywacke and shale	0.53
PTJ-SS-22-09	421857	40	50	limonitic greywacke and shale	1.34
PTJ-SS-22-10	421863	50	60	diorite w/mafic or serp clasts	0.82

Source: Campo (2022)

Note: serp = serpentine.

9.4 2022 LIDAR™ SURVEY

GeoFocus Mapping Inc. was contracted by Stratabound to fly a LiDAR™ survey over the Fremont Property in the spring of 2022. The LiDAR™ survey was completed with a fixed-wing aircraft on April 18, 2022; approximately 51.5 line-km were flown. The surveyed area is shown in Figure 9.4.

FIGURE 9.4 **FREMONT PROPERTY LIDAR™ SURVEY COVERAGE**

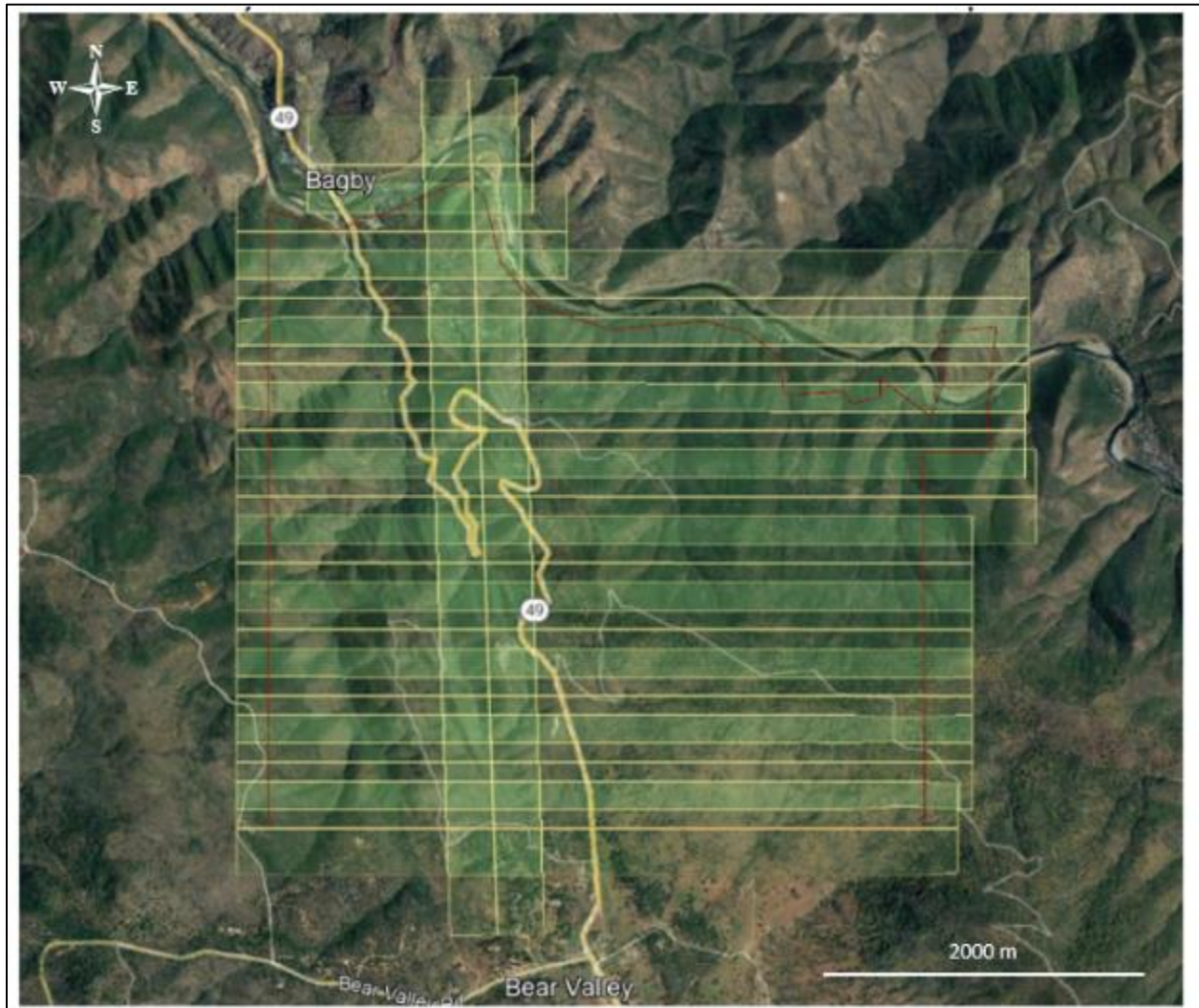

Source: GeoFocus (2022), modified by P&E.

9.5 EXPLORATION POTENTIAL

In addition to the exploration work completed, the Authors established that the four Fremont mineral deposits contain additional Exploration Targets. The Exploration Targets and potential range in tonnages and gold grades are listed in Table 9.3 and represented in Figures 9.5 to 9.9.

The potential quantities and grades of the Exploration Targets are conceptual in nature. There has been insufficient work done by a Qualified Person to define these estimates as Mineral Resources. The Company is not treating these estimates as Mineral Resources, and readers should not place undue reliance on these estimates. Even with additional work, there is no certainty that the estimates will be classified as Mineral Resources. In addition, there is no certainty that these estimates will ever prove to be economically recoverable.

TABLE 9.3
FREMONT EXPLORATION TARGETS

Exploration Target	Tonnage Range (Mt)	Au Grade Range (g/t)
Pine Tree - Josephine Extension	21 to 29	1.8 to 2.0
Queen Specimen Extension	1 to 2	1.1 to 1.3
Chicken Gulch	29 to 40	0.4 to 0.7
Crown Point	1 to 2	0.3 to 0.6

Source: P&E (August 2022)

FIGURE 9.5 FREMONT EXPLORATION TARGETS

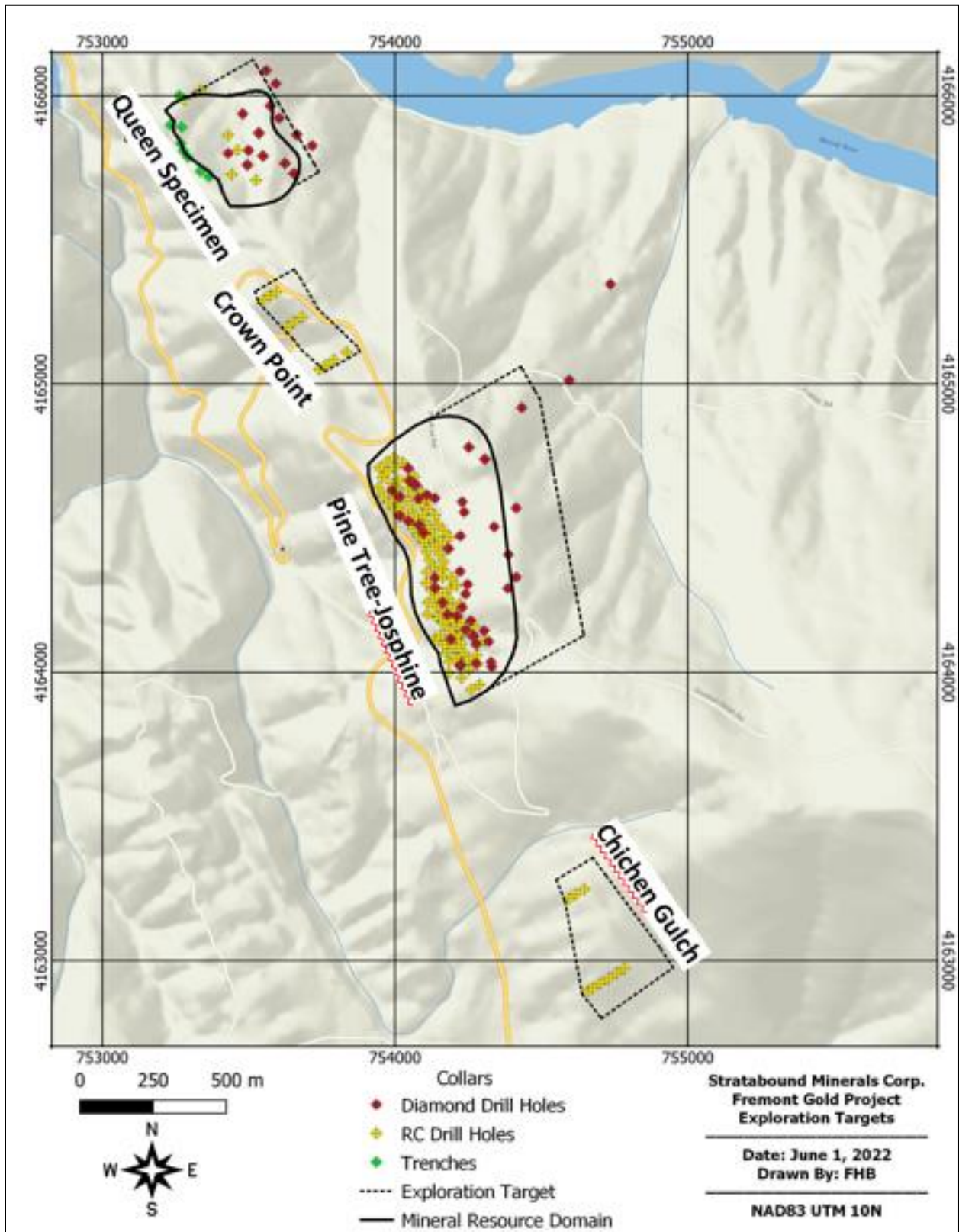

Source: P&E (August 2022)

FIGURE 9.6 PINE TREE-JOSEPHINE EXTENSION EXPLORATION TARGET

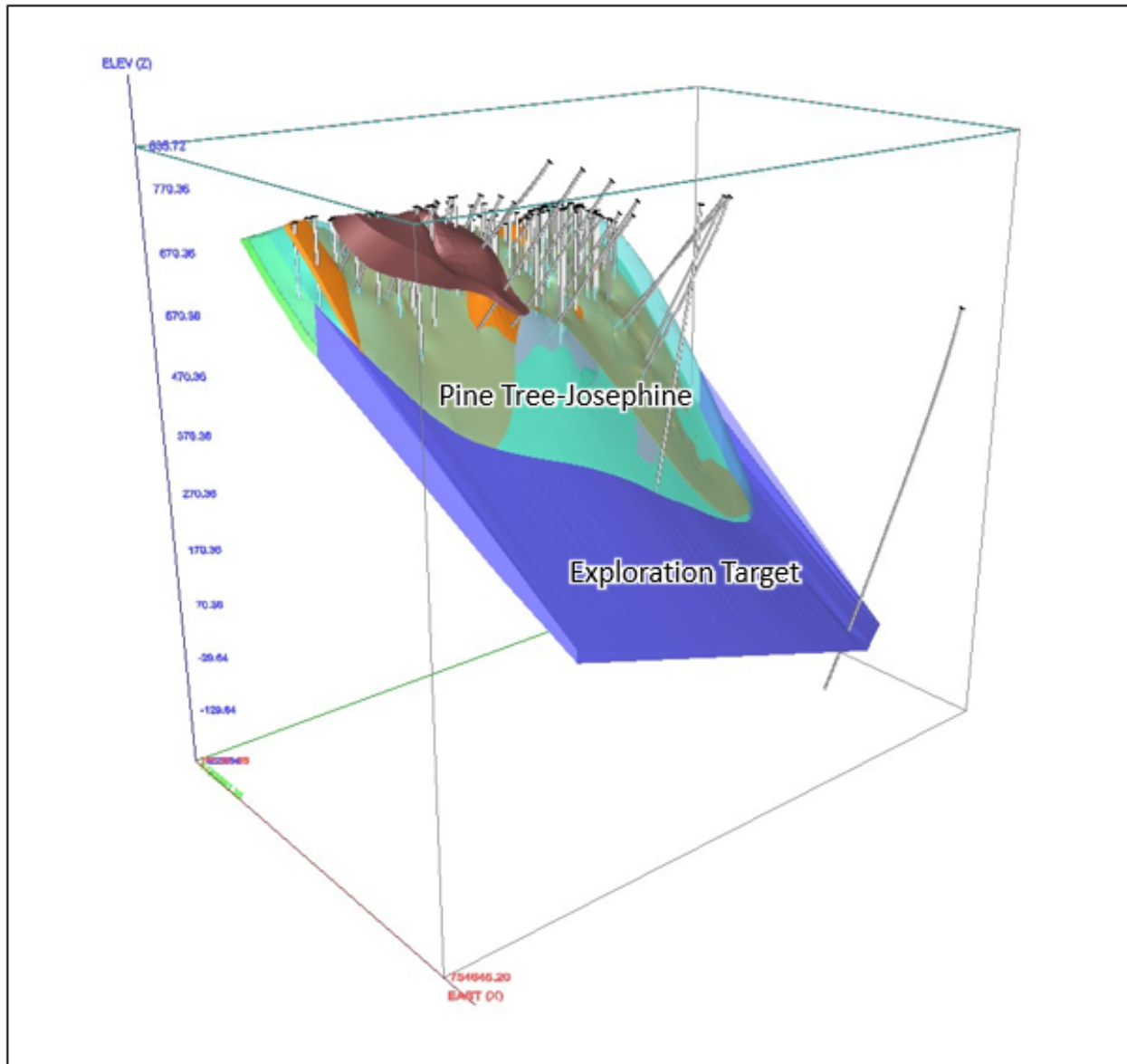

Source: P&E (August 2022)

FIGURE 9.7 **QUEEN SPECIMEN EXTENSION EXPLORATION TARGET**

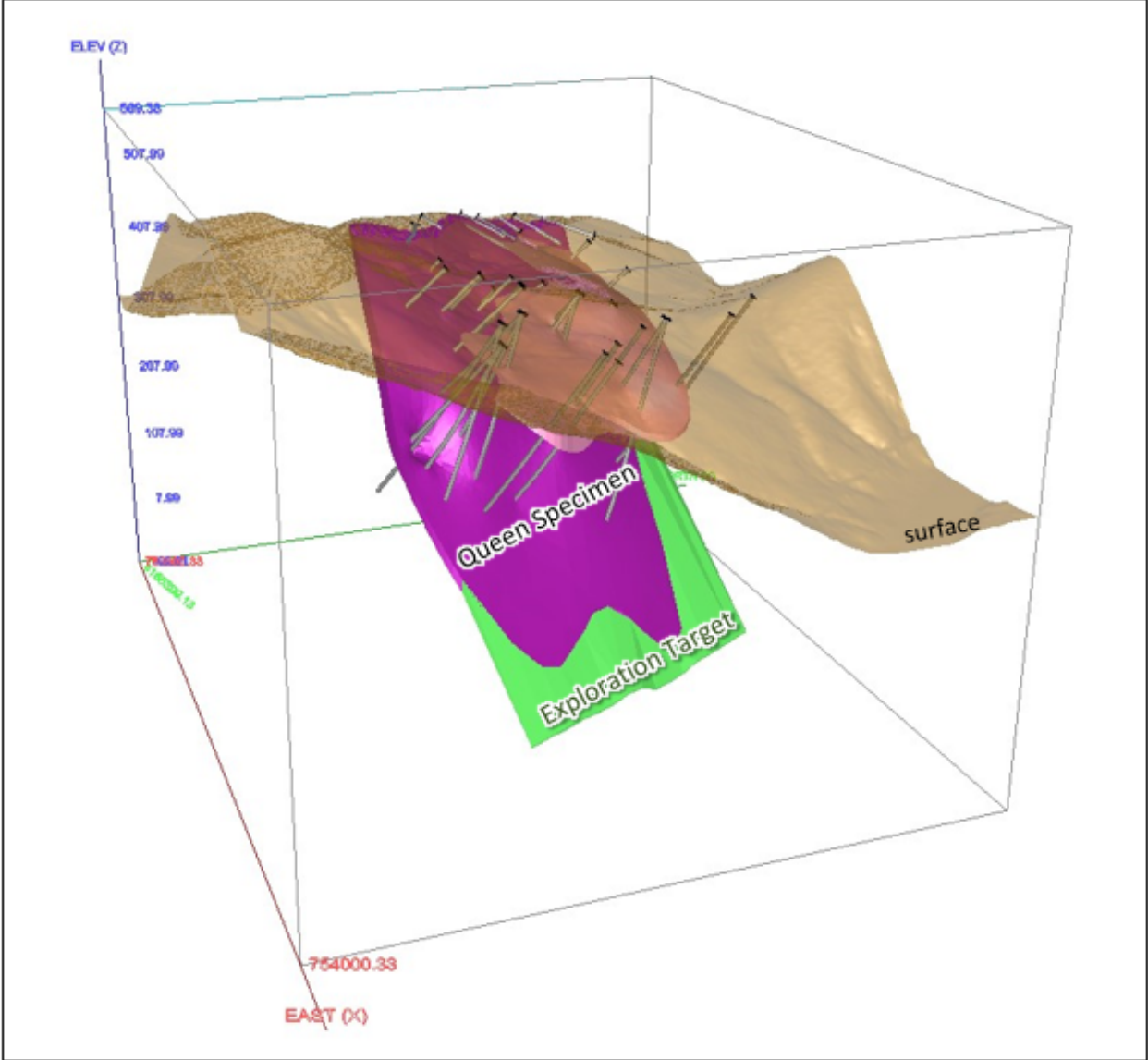

Source: P&E (August 2022)

FIGURE 9.8 CHICKEN GULCH EXPLORATION TARGET

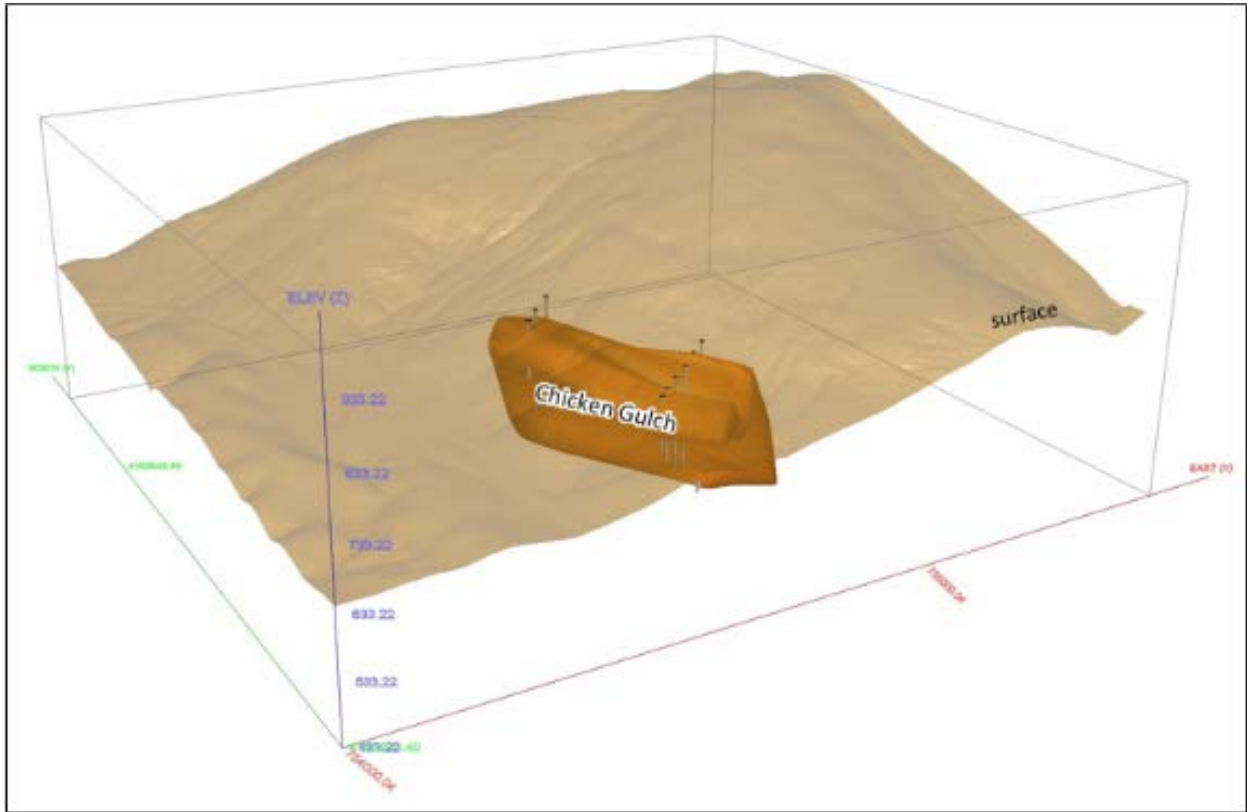

Source: P&E (August 2022)

FIGURE 9.9 CROWN POINT EXPLORATION TARGET

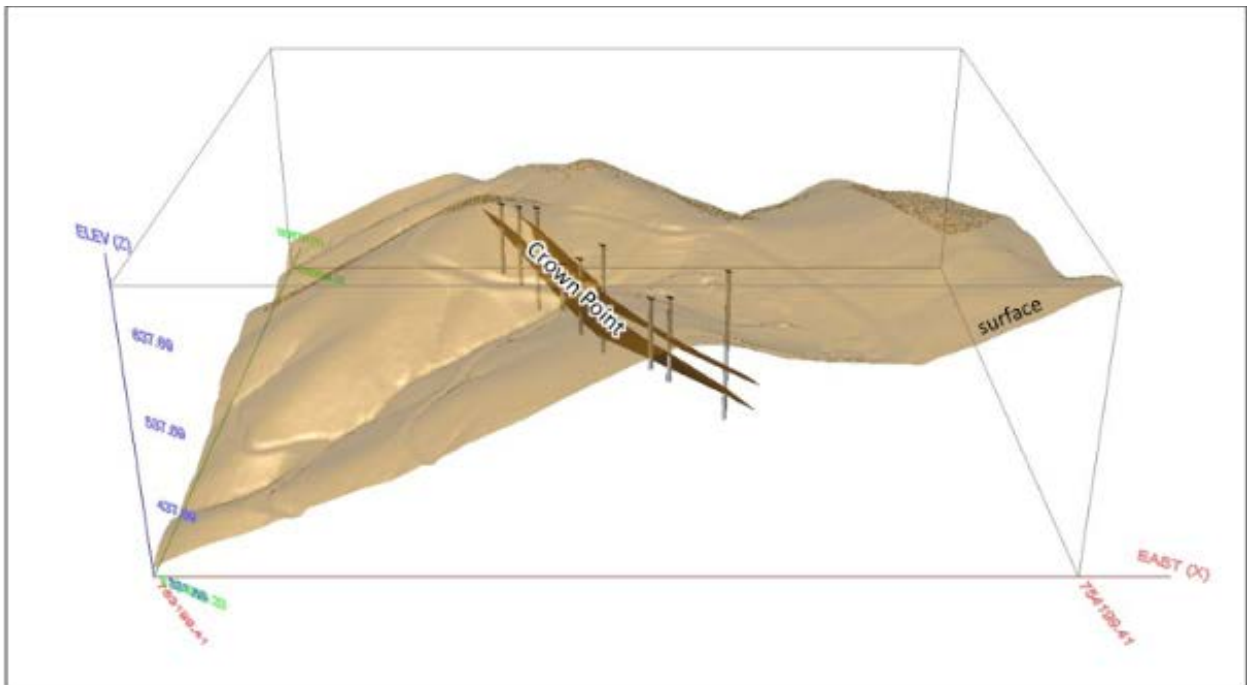

Source: P&E (August 2022)

10.0 DRILLING

Stratabound has not completed any drilling on the Fremont Gold Property as of the effective date of this Report. Since 1985, 283 drill holes totalling 42,010 m (137,830 ft) have been completed by previous owners on the Fremont Property. A summary of this drilling is presented in Table 10.1.

Year	Company	Number of Drill Holes	Length		Drill Type
			(ft)	(m)	
1930s	Pacific Mining Co.	>5	unknown	unknown	core
1985 to 1986	Goldenbell	174	72,393.00	22,065.39	RC, rotary, core
2008	Global Mining	27	538.25	164.06	core
2013 to 2018	California Gold	82	64,898.25	19,781	core
Total		283	137,829.50	42,010.43	

Source: SLR (2021)

10.1 HISTORICAL DRILLING PROGRAMS

Drilling activities at the Property were first undertaken in the 1930s by Pacific Mining Co. that completed limited drilling underground. The only surviving information on those drill holes are outlines on historical level plans. No further drilling was carried out on the Property until 1985.

In 1985 to 1986, Goldenbell initiated a 140 RC drill hole program totalling 19,860 m (65,158 ft) and also drilled 1,196 m (3,925 ft) of rotary (18 drill holes) and 1,009 m (3,310 ft) of core drill holes (16 drill holes). Four targets, namely Pine Tree-Josephine, Queen Specimen-Succedo, Chicken Gulch, and Crown Point, were drilled during 1985 and 1986. The RC drill footage by target area is presented in Table 10.2.

The Pine Tree-Josephine target area was explored by 113 RC drill holes for 16,494 m (54,113 ft) drilled at 30 m (100 ft) north-south intervals and 21 m to 30 m (70 ft to 100 ft) east-to-west intervals with a baseline orientation of 330°. In total 27 north-south cross-section lines (19,600 to 22,300 north) were completed at 30 m intervals. The maximum depth reached was 276 m (905 ft) vertical. All but two holes were drilled vertically. The Pine Tree-Josephine Deposit mineralization was delineated over a length of >823 m (2,700 ft), a width of 122 m to 152 m (400 ft to 500 ft), and a depth of 274 m (900 ft). All drill hole locations were surveyed by Ager, Beretta & Ellis Inc. of Vancouver, BC in 1986.

In the Queen Specimen target area, eight RC drill holes, totalling 861 m (2,825 ft), were completed at an inclination of -45°. These holes were drilled on five cross-sections approximately 61 m (200 ft) apart, with the most northerly section being 180 m (590 ft) apart. A mineralized deposit approximately 366 m (1,200 ft) long and 61 m (200 ft) deep was defined. In the Chicken Gulch target area nine RC drill holes totalling 1,500 m (4,920 ft) were completed on two sections

305 m (1,000 ft) apart. In the Crown Point target area, 10 RC drill holes totalling 1,173 m (3,850 ft) were completed on three cross-sections 180 m (590 ft) and 130 m (425 ft) apart.

No further drilling was carried out on the Property until 2008.

TABLE 10.2			
SUMMARY OF GOLDENBELL 1985-1986 DRILLING			
Target	Number of Drill Holes	Length	
		(ft)	(m)
Pine Tree-Josephine	113	54,113	16,494
Queen Specimen	8	2,825	861
Crown Point	10	3,300	1,006
Chicken Gulch	9	4,920	1,500
Total	140	65,158	19,860

Source: SLR (2021)

In 2008, Global Mining completed a 27 vertical hole drilling program totalling 164.06 m (538.25 ft) in the historical tailings dump near the Pine Tree Mine.

10.2 RECENT DRILLING PROGRAMS

California Gold completed 82 surface diamond drill holes from 2013 to 2018, totalling 19,781.00 m (64,898.25 ft). Of the 82 drill holes, 52 were drilled into the Pine Tree-Josephine Deposit, 26 into the Queen Specimen Deposit, and four in the historical French Mine area (Figure 10.1 and Table 10.3).

Drill hole collar surveys were completed in the field using a hand-held GPS. At the end of the 2016 program, the collar locations were independently surveyed by Freeman and Seaman Land Surveyors. Downhole surveys in the 2013-2014 holes were completed with a Reflex EZ-shot. The 2015-2016 holes were surveyed using a Devico peewee or DeviShot instrument. Downhole surveys were taken every 30 m to 61 m (100 ft to 200 ft) and at the end of hole by the drillers. Drill hole surveys in the 2017-2018 program were taken every 15 m (50 ft). For the 2016 Mineral Resource Estimate, the drill hole database was converted from local coordinate system (mine grid) to NAD83 Zone 10 UTM coordinates and expressed in metric units.

FIGURE 10.1 FREMONT PROPERTY DRILL TARGETS 2013 TO 2018, PLAN VIEW

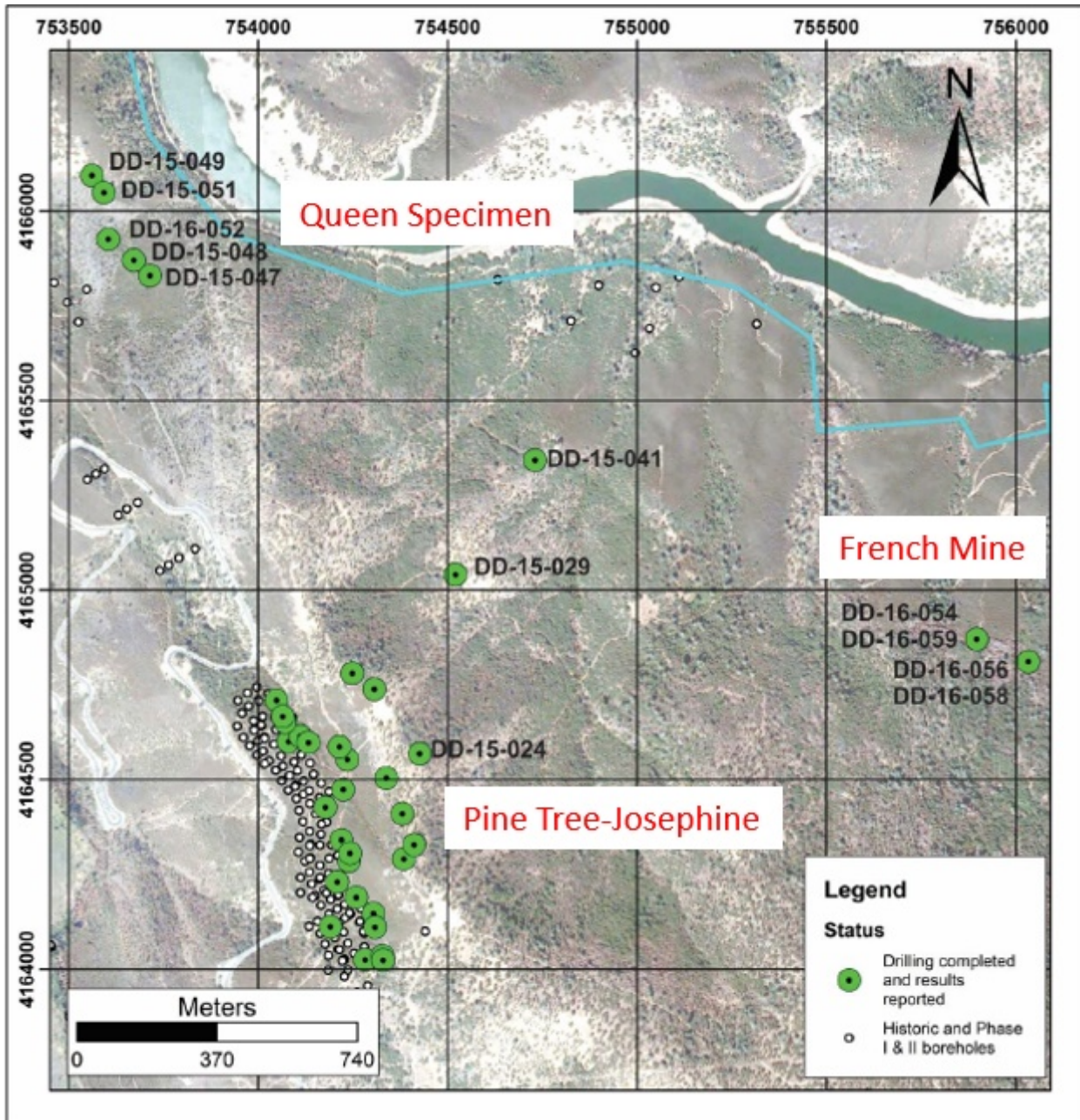

Source: California Gold press release (October 3, 2016)

TABLE 10.3 CALIFORNIA GOLD DRILLING 2013-2018				
Target	Number of Drill Holes	Length		Year
		(ft)	(m)	
Pine Tree-Josephine	52	40,809.55	12,438.75	2013 to 2016
Queen Specimen	26	19,636.50	5,985.21	2015 to 2018
French Mine Area	4	4,452.20	1,357.03	2016
Total	82	64,898.25	19,781.00	

Source: SLR (2021)

10.2.1 Pine Tree-Josephine Drilling: 2013-2016

The 52 drill holes completed at Pine Tree-Josephine included 14 twin holes drilled to confirm historical RC hole results and three holes drilled to recover materials for metallurgical test work. All the holes in the Pine Tree-Josephine area were drilled toward the southwest to intercept the northeast-dipping Melones Fault Zone and associated gold mineralized quartz veins. The drilling was carried out by National Drilling in 2013-2014 and by KB Drilling in 2015-2016. Drill core size was primarily HQ, however, NQ size was drilled where required by ground conditions.

10.2.1.1 Phase I Drilling 2013

The Phase I drilling program ran from May 22, 2013 to June 21, 2013, and included 14 diamond drill holes totalling 1,982 m (6,502 ft). The main objective of the drill program was to twin 14 of the 1985-1986 RC drill holes drilled by Goldenbell on the Fremont Property with new HQ 64 mm (2.5 inch) diameter diamond drill holes. Drill collar locations and interpreted cross-sectional projections are shown in Figures 10.2 to 10.3. Highlight composited assay results for the Phase 1 drill holes are presented in Table 10.4.

FIGURE 10.2 PHASE I (2013) DIAMOND DRILL HOLES, PLAN VIEW

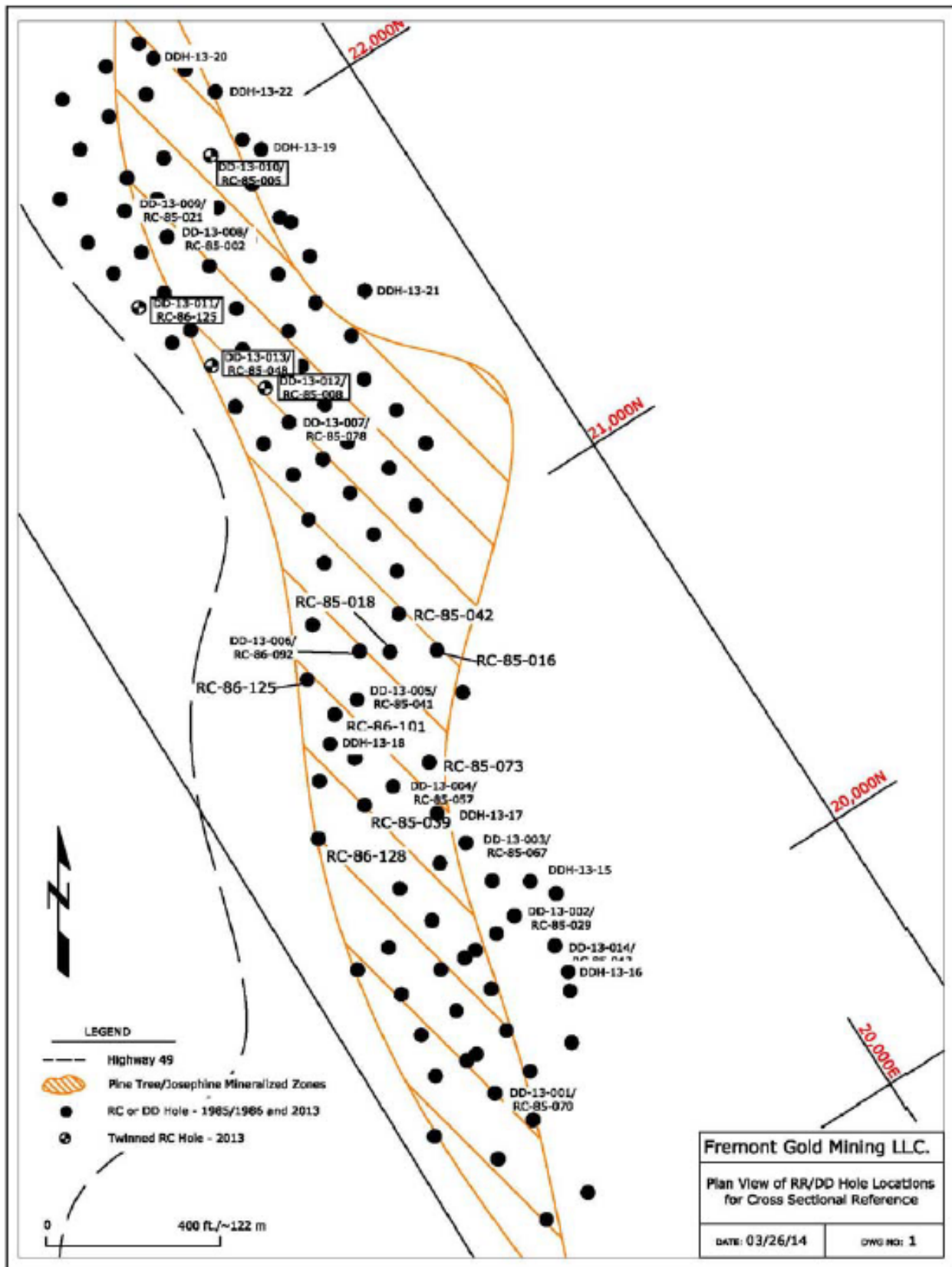

Source: California Gold (press release dated April 14, 2014)

FIGURE 10.3 VERTICAL CROSS-SECTIONAL PROJECTION 20,000 M N

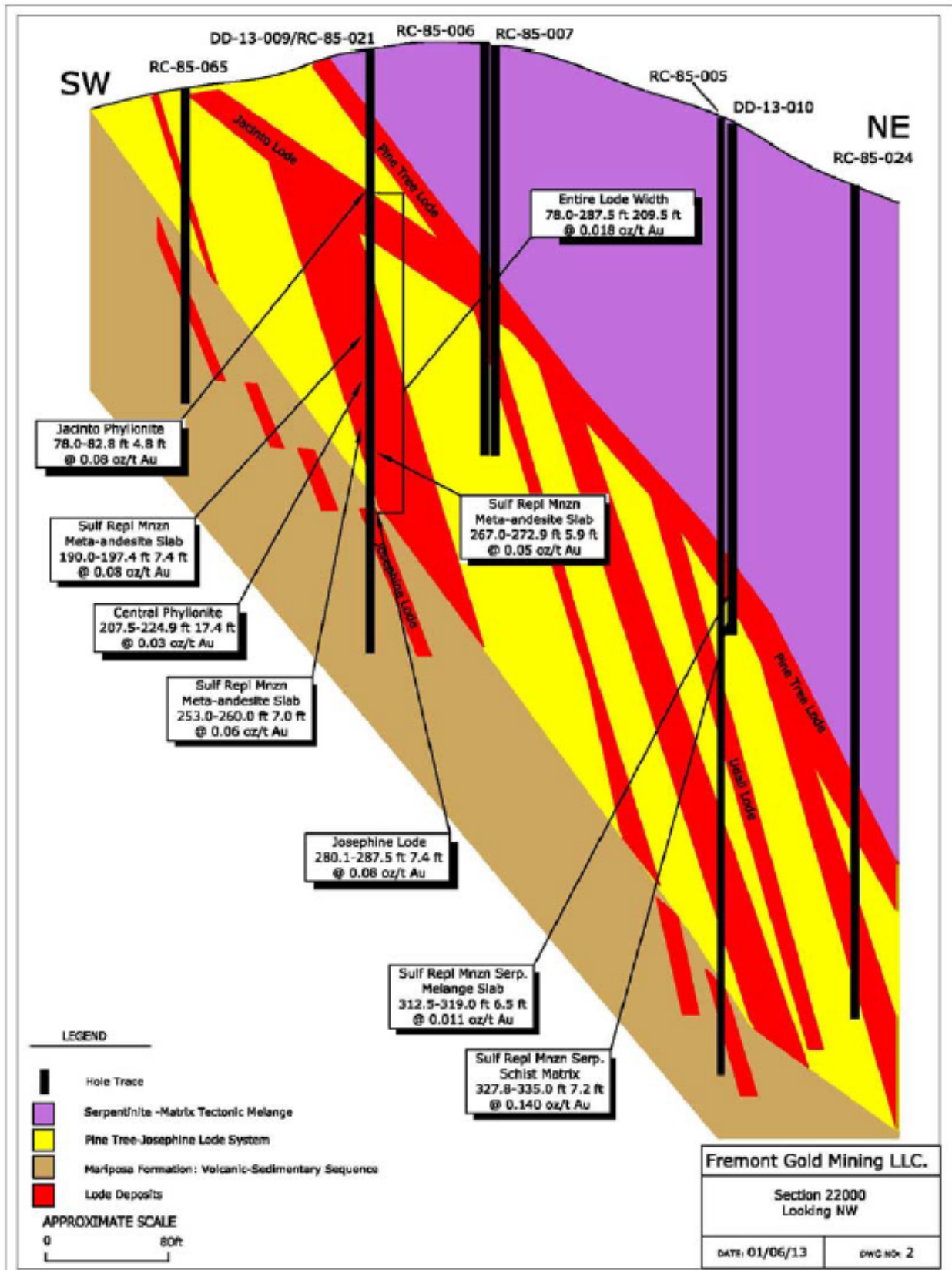

Source: California Gold press release (April 14, 2014)

**TABLE 10.4
PINE TREE-JOSEPHINE PHASE I (2013) DRILLING HIGHLIGHTS**

Drill Hole ID	From (ft)	To (ft)	Interval (ft)	Au (oz/ton)	Au (g/t)
DD-13-04	201.5	385.0	183.5	0.07	2.54
RC-85-057 (Historical)	205.0	370.0	165.0	0.07	2.50
DD-13-05	115.0	282.5	167.5	0.06	2.06
RC-85-041 (Historical)	130.0	280.0	150.0	0.05	1.71
DD-13-06	99.5	282.4	182.9	0.06	2.19
RC-86-092 (Historical)	110.0	310.0	200.0	0.10	3.50
DD-13-07	190.0	330.2	140.2	0.04	1.20
RC-85-078 (Historical)	195.0	345.0	150.0	0.03	1.17
DD-13-08	142.5	329.8	250.3	0.06	2.16
RC-85-002 (Historical)	135.0	395.0	260.0	0.05	1.65
DD-13-09	78.0	387.5	209.5	0.02	0.62
RC-85-021 (Historical)	79.0	290.0	215.0	0.03	1.17
DD-13-10	hole lost prior to mineralized zone				
DD-13-11	8.1	74.4	66.3	0.01	0.38
RC-86-127 (Historical)	7.6	73.2	65.6	0.03	0.96
DD-13-12	64.0	143.3	79.3	0.04	1.44
RC-85-008 (Historical)	57.9	137.2	79.3	0.05	1.61
DD-13-13	29.7	88.3	58.6	0.03	1.06
RC-85-048 (Historical)	22.9	86.9	64.0	0.03	0.99

Source: California Gold press releases dated October 28, November 25, 2013 and April 14, 2014.

Notes: Assay results from Phase I holes DD-13-01, DD-13-02, DD-13-03 and DD-13-14 were not released due to QA/QC issues with those holes.

The results from the Phase I drill program confirmed presence of a large gold-mineralized zone at Pine Tree-Josephine and in the development of a preliminary geological model for the Deposit. The large widths of the mineralized intersections and high overall gold grades encountered in the mineralized zones were considered to present a compelling case for Fremont to be evaluated as a bulk mining operation.

Based on the Phase I results, it was determined that more drilling was required for an initial Mineral Resource Estimate for the Fremont Property.

10.2.1.2 Phase II Drilling 2014

The Phase II drilling program at Fremont commenced on December 17, 2013 and concluded on January 29, 2014. Four PQ-sized diamond drill holes were drilled totaling 568 m (1,862 ft). The main objective of the Phase II drill program was to generate sufficient representative rock material from each of the three identified metallurgical domains that have recently been identified at the Fremont Property, to initiate PEA-level metallurgical testing. The three metallurgical

domains identified were: 1) quartz-hosted gold mineralization; 2) sulphide replacement gold mineralization; and 3) oxide cap mineralization.

Collar locations for the Phase II drill holes are shown in plan and section views in Figures 10.4 and 10.5. Assay highlights from the four drill holes are presented in Table 10.5.

FIGURE 10.4 PINE TREE-JOSEPHINE DEPOSIT PHASE II DIAMOND DRILLING 2015, PLAN VIEW

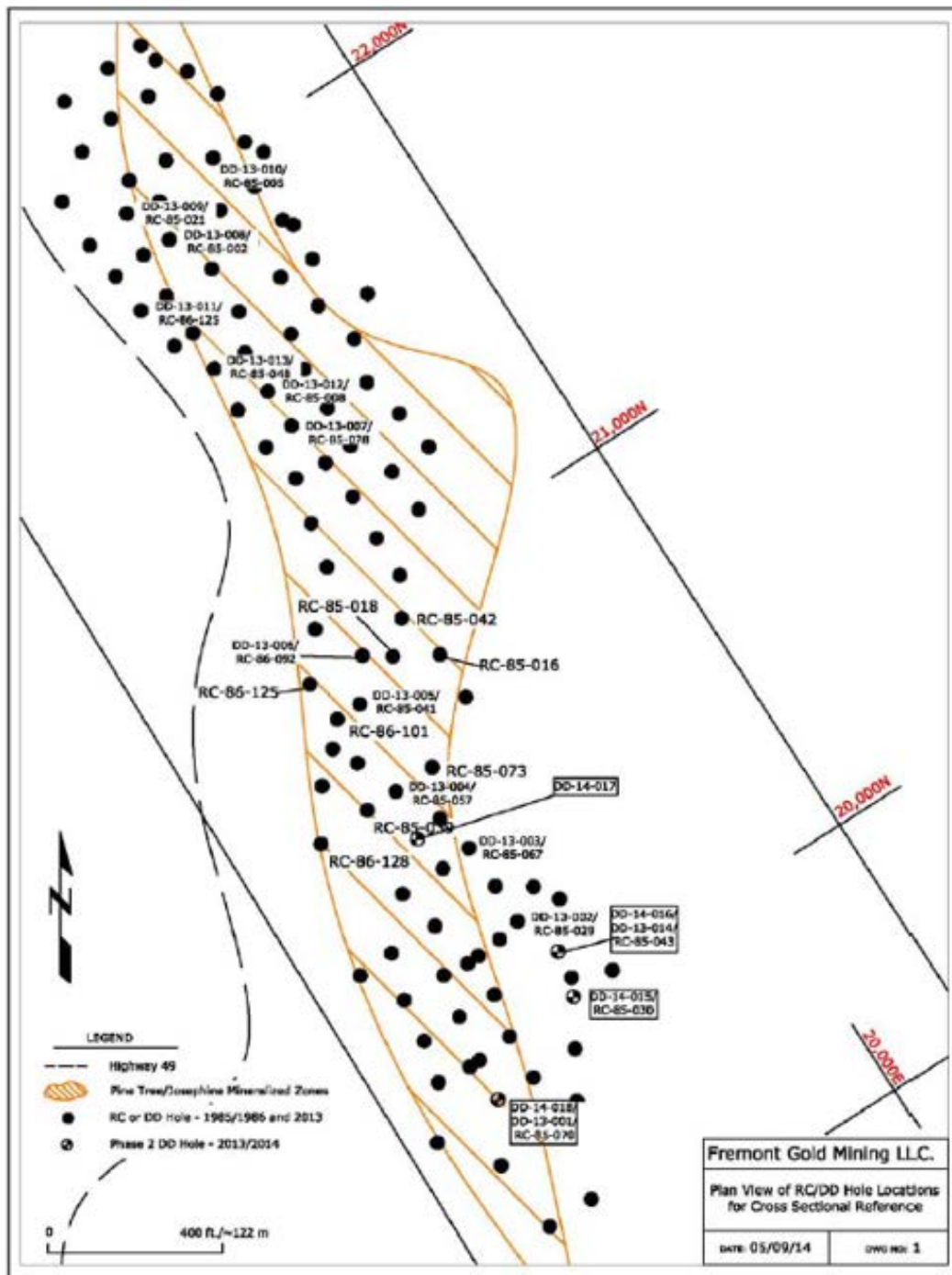

Source: California Gold press release (May 9, 2014).

FIGURE 10.5 VERTICAL CROSS-SECTIONAL PROJECTION 22,000 M N

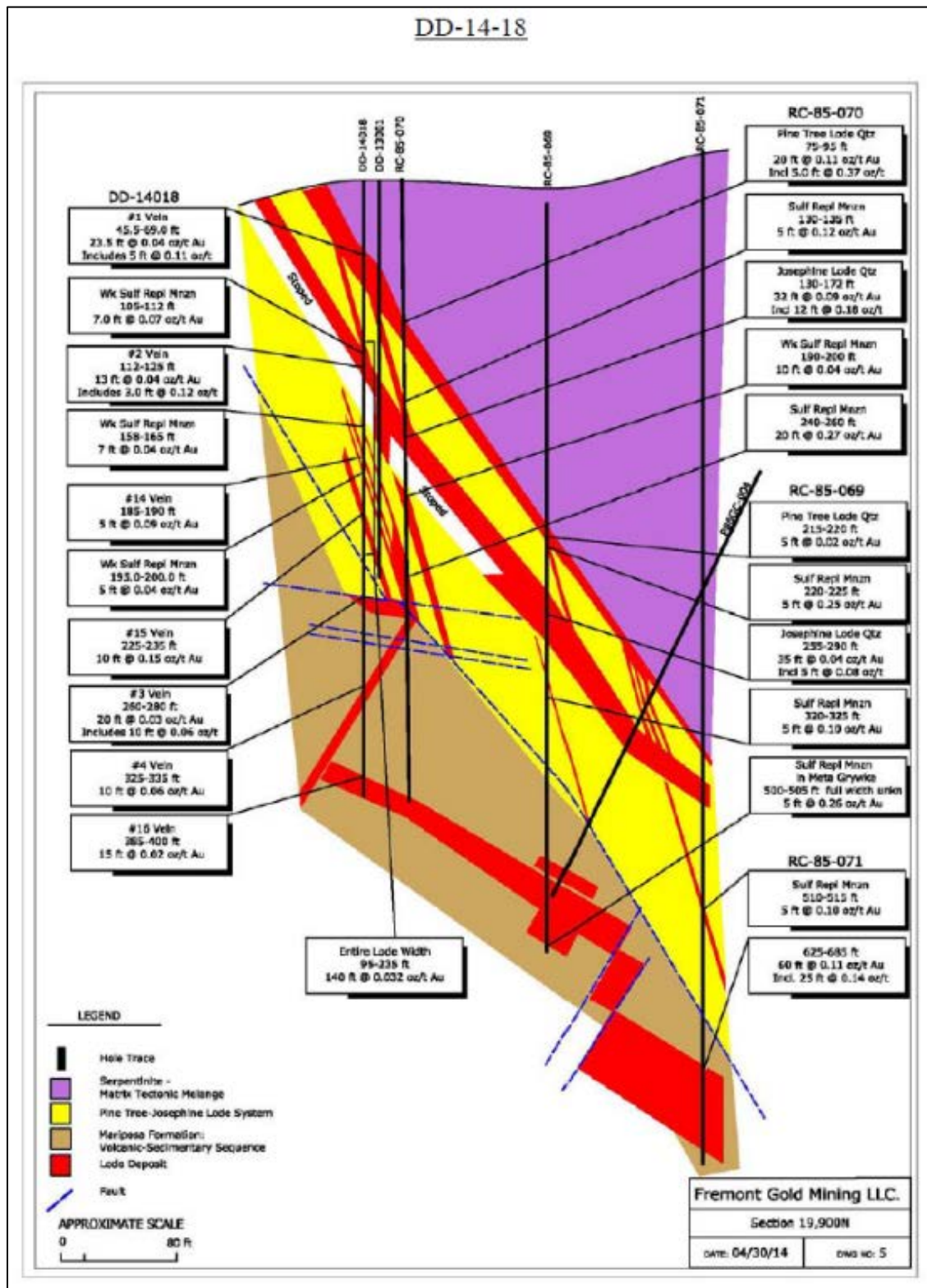

Source: California Gold press release (May 9, 2014).

Note: Drill hole DD-14-18 was a vertical hole drill to a depth of 123.8 m. The weighted average composited gold fire assays in the hole extend from the Pine Tree Quartz No. 1 Vein lode (29.0 m depth) to the footwall of the No. 15 Vein lode (71.6 m depth) averaging 1.10 g/t Au along 42.7 m.

**TABLE 10.5
PINE TREE-JOSEPHINE PHASE II (2014) DRILLING RESULTS**

Drill Hole ID	Azimuth (deg)	Dip (deg)	Total Depth (m)	From (m)	To (m)	Interval (m)	Au (oz/t)	Au (g/t)
DD-14-15	273	-63	174.3	93.0	115.4	62.5	0.05	1.82
including				93.0	94.5	1.5	0.12	4.11
including				116.4	120.2	3.8	0.08	2.74
including				127.3	137.9	10.7	0.06	2.06
including				137.9	142.5	4.6	0.21	7.20
including				150.8	152.4	1.6	0.22	7.54
DD-14-16	276	-63	161.6	92.5	148.6	56.1	0.07	2.47
including				92.5	99.1	6.6	0.08	2.74
including				125.7	126.8	1.1	0.09	3.09
including				136.4	143.6	7.3	0.16	5.49
including				143.6	148.6	5.0	0.14	4.80
DD-14-17	273	-60	108.2	49.8	76.2	26.4	0.05	1.68
including				55.2	57.9	2.7	0.11	3.77
including				69.5	76.2	6.7	0.11	3.77
DD-14-18	0	-90	123.8	29.0	71.6	42.7	0.03	1.10
including				13.9	21.0	7.2	0.04	1.37
including				32.0	34.1	2.1	0.07	2.40
including				56.4	57.9	1.5	0.09	3.09
including				68.6	71.6	3.0	0.15	5.14

Source: California Gold press release dated May 9, 2014.

Note: Assay composites include up to 8 m of waste.

The results from all four Phase II drill holes correlated well with the geology documented during historical RC drilling, underground mapping and mine development sampling programs. The Phase II drill program successfully generated sufficient representative rock material from each of the three metallurgical domains on the Fremont Property to conduct PEA-level metallurgical studies.

10.2.1.3 Phase III Drilling 2015-2016

The objectives of the Phase III drilling program were three-fold: 1) generate sufficient data to support preparation of an initial Mineral Resource Estimate for the Pine Tree-Josephine mineralized zone; 2) test the down-dip extension of the Pine Tree-Josephine mineralized zone to depths of up to 914 m (3,000 ft) below surface; and 3) drill test additional targets on the Fremont Property for mineralization potential. The Phase III drilling program commenced on September 11, 2015 and concluded on March 5, 2016. The program consisted of 43 HQ-size diamond drill holes totalling 12,549 m (41,171 ft).

32 of the drill holes (DD-15-19 to DD-15-050) were infill holes completed at the main Pine Tree-Josephine mineralized zone for the Mineral Resource estimation. In addition to the in-fill drill holes, four deep holes (DD-16-053, DD-16-055, DD-16-057, DD-16-060) were completed to intersect the mineralized shear zone in the Pine Tree-Josephine system at depths of up to 914 m (3,000 ft) below surface. Up to 15 shallow drill holes were completed on the additional targets. During the program, up to five diamond drill rigs were operating on-site.

A plan view of the Phase III drill hole locations and an interpreted geological cross-section are shown in Figures 10.6 to 10.7, respectively. Highlight assay results are presented in Table 10.6.

FIGURE 10.6 PINE TREE-JOSEPHINE AREA PHASE III DRILLING (2015-2016) PLAN VIEW

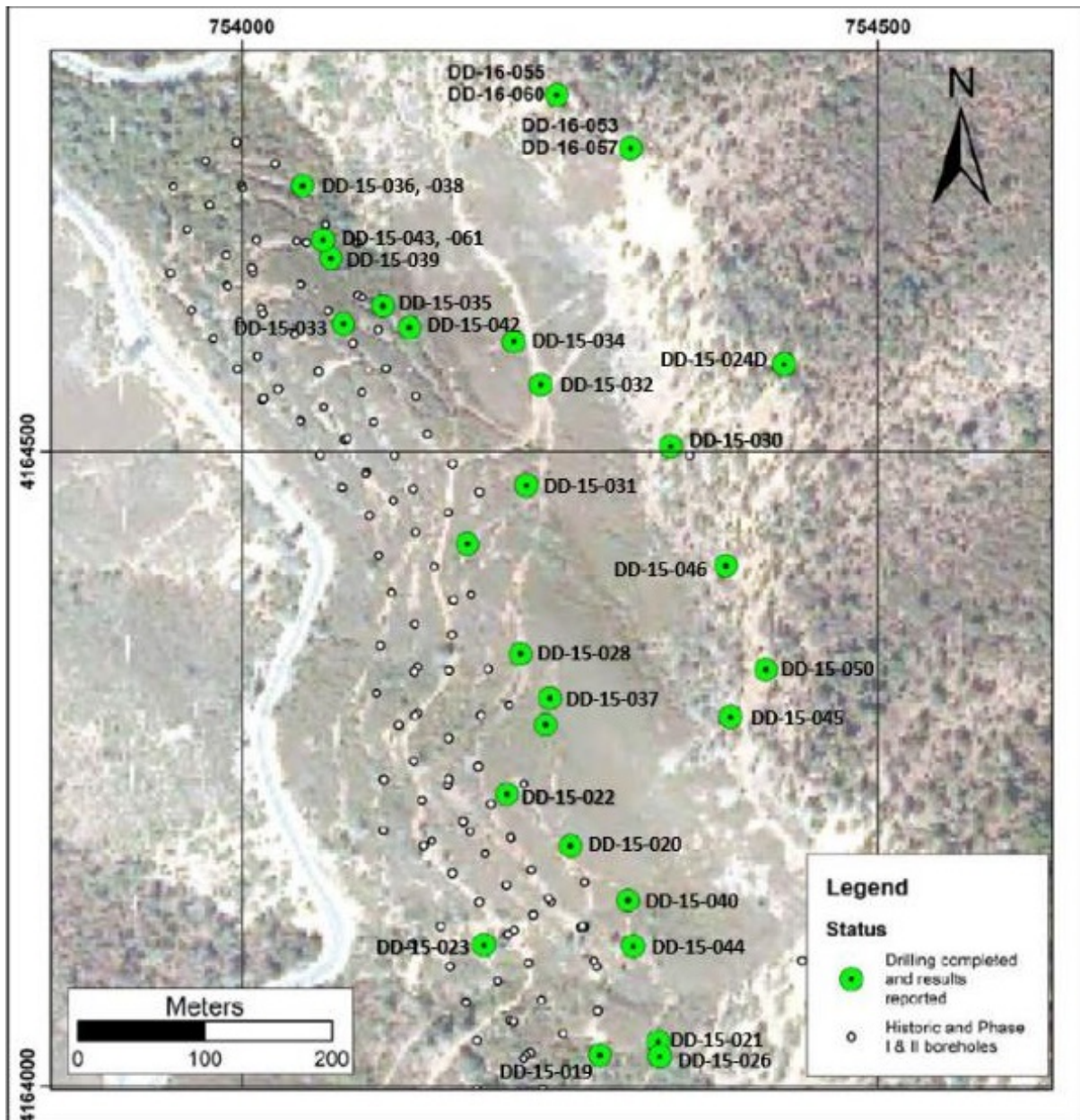

Source: California Gold press release (June 1, 2016)

FIGURE 10.7 PINE TREE-JOSEPHINE PHASE III INTERPRETED VERTICAL CROSS-SECTIONAL PROJECTION 21,975 N

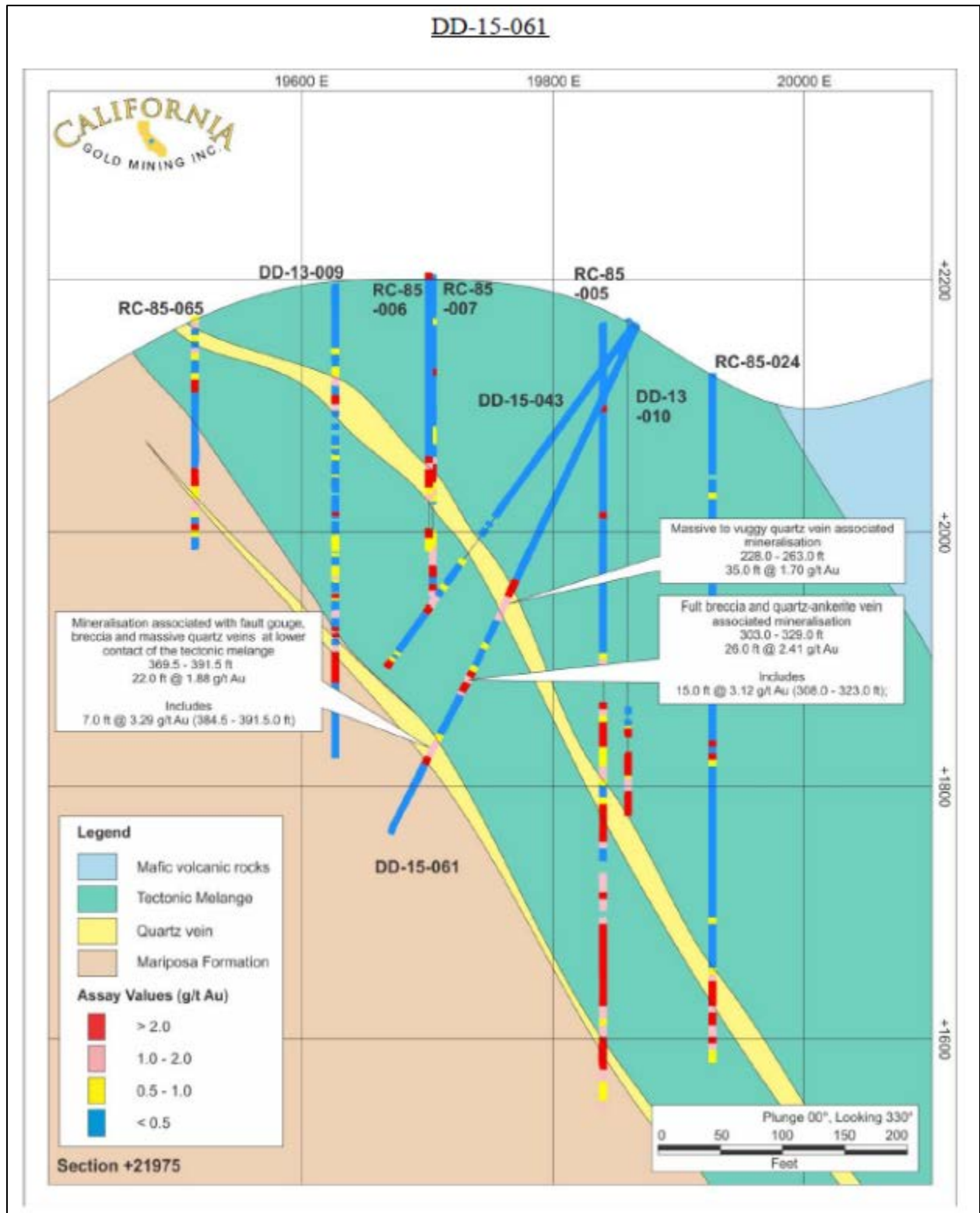

Source: California Gold press release (May 9, 2016)

TABLE 10.6
PINE TREE-JOSEPHINE PHASE III (2015-16) DRILLING RESULTS (6 PAGES)

Drill Hole ID	Azimuth (deg)	Dip (deg)	Total Depth (ft)	Total Depth (m)	From (ft)	To (ft)	Interval (ft)	From (m)	To (m)	Interval (m)	Au (oz/t)	Au (g/t)
DD-15-019	240	-57	573		202.3	226	23.7			7.2	0.07	2.46
including					205	211	6			1.8	0.09	3.24
including					213.5	216	2.5			0.8	0.25	8.64
including					219.4	222.7	3.3			1.0	0.09	3.15
DD-15-020	255	-54	668		351	439.5	88.5			27.0	0.06	1.90
including					351	355	4			1.2	0.55	18.89
including					368	370.5	2.5			0.8	0.12	4.18
including					431	434.5	3.5			1.1	0.17	5.79
also					469	519	50			15.2	0.08	2.76
including					501.3	504	2.7			0.8	0.13	4.32
including					517	519	2			0.6	1.06	36.24
DD-15-021	252	-68	667		97.5	104.1	6.6			2.0	0.06	1.91
including					97.5	100.3	2.8			0.9	0.09	3.05
also					423	435.7	12.7			3.9	0.05	1.58
including					423	426	3			0.9	0.08	2.71
including					432	435.7	3.7			1.1	0.07	2.5
also					607	644	37			11.3	0.03	1.05
including					607	611.6	4.6			1.4	0.07	2.23
including					634.3	639.15	4.85			1.5	0.12	4.05
DD-15-022	240	-74	638		164.7	174.7	10.0			3.0	0.12	4.11
and					368	407.1	39.1			11.9	0.10	3.52
including					390.5	407.1	16.6			5.1	0.19	6.57
and					522.7	557.5	34.8			10.6	0.11	3.68
including					522.7	538	15.3			4.7	0.13	4.45
including					554.8	557.5	2.7			0.8	0.44	14.91

TABLE 10.6
PINE TREE-JOSEPHINE PHASE III (2015-16) DRILLING RESULTS (6 PAGES)

Drill Hole ID	Azimuth (deg)	Dip (deg)	Total Depth (ft)	Total Depth (m)	From (ft)	To (ft)	Interval (ft)	From (m)	To (m)	Interval (m)	Au (oz/t)	Au (g/t)
DD-15-023	267	-66	369		97	122	25.0			7.6	0.10	3.57
including					97	102	5.0			1.5	0.27	9.33
including					118.5	122.0	3.5			1.1	0.12	4.18
and					204.3	237.5	33.2			10.1	0.06	2.05
including					209	216	7.0			2.1	0.10	3.48
including					229.0	233.0	4.0			1.2	0.12	4.22
DD-15-025	240	-62	631.5		419.2	496.0	76.8			23.4	0.06	2.23
including					419.2	424.2	5.0			1.5	0.13	4.53
including					463.3	468.3	5.0			1.5	0.09	3.09
including					478.4	490.4	12.0			3.7	0.18	6.32
and					508.4	514.5	6.1			1.9	0.11	3.67
and					538.0	546.5	8.5			2.6	0.16	5.62
including					542.0	546.5	4.5			1.4	0.26	8.74
DD-15-026	240	-55		190.0				35.7	43.8	8.1		1.49
including								35.7	37.8	2.1		2.51
and								105.6	110.2	4.6		7.25
including								105.6	106.7	1.1		9.33
including								109.1	110.2	1.1		18.41
DD-15-027	240	-55	498.0		398.7	432.0	33.3			10.1	0.11	3.91
including					409.6	421.8	12.2			3.7	0.19	6.52
including					424.0	430.0	6.0			1.8	0.11	3.75
DD-15-028	240	-55		167.6				133.33	154.8	21.5		1.96
including								133.3	136.5	3.2		3.30
including								146.3	149.3	3.0		3.55
DD-15-030	240	-55	1,098.6		932.5	982.3	49.8			15.2	0.08	2.70

TABLE 10.6
PINE TREE-JOSEPHINE PHASE III (2015-16) DRILLING RESULTS (6 PAGES)

Drill Hole ID	Azimuth (deg)	Dip (deg)	Total Depth (ft)	Total Depth (m)	From (ft)	To (ft)	Interval (ft)	From (m)	To (m)	Interval (m)	Au (oz/t)	Au (g/t)
including					939	945	6.0			1.8	0.15	5.09
including					957	966	9.0			2.7	0.14	4.70
and					1,068	1,072	4.0			1.2	0.10	3.50
DD-15-031	240	-55		199.0				172.8	175.8	3.0		4.40
including								172.8	174.0	1.2		8.19
DD-15-032	240	-55		229.5				112.2	117.9	5.7		1.12
and								195.1	196.6	1.5		3.43
and								209.0	215.9	6.9		1.16
DD-15-033	240	-60		140.5				77.1	78.0	0.9		7.14
and								128.0	135.6	7.6		2.67
including								128.0	129.7	1.7		3.40
including								132.6	134.1	1.5		4.77
DD-15-034	240	-55		235.6				198.2	201.2	3.0		1.34
and								211.5	213.3	1.8		3.79
including								211.5	212.4	0.9		4.73
and								218.8	226.2	7.4		1.27
including								225.5	226.2	0.7		3.74
DD-15-035	244	-62		168.25				99.7	100.8	1.1		18.58
also								134.7	137.8	3.1		8.45
including								134.7	136.2	1.5		15.29
DD-15-036	240	-55		127.4	233.0	253.0		71.0	77.1	6.1		1.46
and					313.8	331.0		95.6	100.9	5.2		3.72
including					318.8	322.2		97.2	98.2	1.0		11.04
DD-15-037	240	-65		200.3	496.4	504.0		151.3	153.6	2.3		1.52
and					517.5	523.5		157.7	159.6	1.8		2.35

TABLE 10.6
PINE TREE-JOSEPHINE PHASE III (2015-16) DRILLING RESULTS (6 PAGES)

Drill Hole ID	Azimuth (deg)	Dip (deg)	Total Depth (ft)	Total Depth (m)	From (ft)	To (ft)	Interval (ft)	From (m)	To (m)	Interval (m)	Au (oz/t)	Au (g/t)
and					561.0	571.0		171.0	174.0	3.0		3.15
and					598.5	618.0		182.4	188.4	5.9		2.47
including					598.5	603.0		182.4	183.8	1.4		5.45
DD-15-038	240	-75		137.8	287.0	329.2		87.5	100.3	12.9		6.63
including					290.2	296.0		88.5	90.2	1.8		18.02
including					322.2	325.7		98.2	99.3	1.1		36.58
DD-15-039	260	-55		137.8				74.8	79.3	4.6		5.84
including								74.8	76.4	1.6		7.57
including								78.7	79.3	0.6		20.71
and								83.0	89.1	6.1		1.43
including								85.4	86.6	1.2		3.26
and								114.1	122.4	8.3		2.47
including								115.9	120.4	4.5		3.38
DD-15-040	240	-65		258.84				87.2	92.7	5.5		1.01
also								155.3	166.8	11.5		1.41
including								156.2	168.5	12.3		2.01
including								160.5	162.6	2.1		2.35
including								164.8	166.8	2.0		1.87
also								171.8	182.3	10.5		2.31
including								173.0	175.4	2.4		3.89
also								195.1	197.7	2.6		4.03
including								195.1	196.0	0.9		7.95
also								207.9	209.6	1.7		1.74
DD-15-042	240	-55		143.1				131.4	132.9	1.5		1.70
also								142.0	143.1	1.1		1.74

TABLE 10.6
PINE TREE-JOSEPHINE PHASE III (2015-16) DRILLING RESULTS (6 PAGES)

Drill Hole ID	Azimuth (deg)	Dip (deg)	Total Depth (ft)	Total Depth (m)	From (ft)	To (ft)	Interval (ft)	From (m)	To (m)	Interval (m)	Au (oz/t)	Au (g/t)
DD15-043	240	-55		106.7				82.0	86.7	4.7		2.00
including								84.7	86.6	1.9		2.79
and								100.0	103.0	3.0		3.47
including								100.9	101.8	0.9		7.54
DD-15-044	260	-65		195.4				9.1	15.6	6.5		1.52
and								50.6	59.7	9.1		1.32
and								91.7	97.8	6.1		2.87
including								94.8	96.3	1.5		6.58
and								145.1	163.4	18.3		2.01
including								151.2	154.2	3.0		5.90
and								167.4	184.7	17.3		1.91
including								172.5	175.5	3.0		3.64
and								178.8	180.1	1.3		5.70
DD-15-045	240	-55		335.9				285.6	290.2	4.6		1.23
and								294.9	299.6	4.7		2.01
including								297.8	298.6	0.8		5.35
and								310.0	314.9	4.9		6.91
including								314.2	314.9	0.7		43.03
DD-15-046	240	-55		335.3				311.1	316.9	5.8		3.68
including								311.8	313.4	1.6		5.29
DD-15-050	240	-55		383.7				317.1	322.5	5.4		1.14
and								329.8	333.5	3.7		1.85
including								330.7	331.6	0.9		4.44
and								342.7	351.1	8.4		3.58
including								342.7	345.2	2.5		5.73

TABLE 10.6
PINE TREE-JOSEPHINE PHASE III (2015-16) DRILLING RESULTS (6 PAGES)

Drill Hole ID	Azimuth (deg)	Dip (deg)	Total Depth (ft)	Total Depth (m)	From (ft)	To (ft)	Interval (ft)	From (m)	To (m)	Interval (m)	Au (oz/t)	Au (g/t)
DD-16-053	240	-70		460.6				362.4	370.6	8.2		4.43
including								362.4	363.9	1.5		7.89
including								365.5	366.7	1.2		4.66
including								368.2	369.7	1.5		6.45
DD-16-055	240	-70		447.4				335.9	340.2	4.3		0.94
and								368.7	370.5	1.8		1.53
DD-16-057	240	-55		396.2				326.7	330.7	4.0		2.68
including								326.7	328.2	1.5		4.05
and								358.1	364.2	6.1		1.59
including								361.2	362.7	1.5		3.15
DD-16-060	240	-57		380.4				309.1	313.0	3.9		1.23
and								330.9	342.3	11.4		2.70
including								330.9	333.8	2.9		4.03
including								334.7	336.7	2.0		4.40
including								341.4	342.3	0.9		4.80
DD-15-061	250	-65		138.1				69.5	80.2	10.7		1.70
and								92.4	100.3	7.9		2.41
including								93.9	98.5	4.6		3.12
and								112.6	119.3	6.7		1.88
including								117.2	119.3	2.1		3.29

Sources: California Gold press releases (dated November 9, 2015; November 23, 2015; December 15, 2015; January 18, 2016; February 17, 2016; March 30, 2016; April 27, 2016; May 9, 2016; June 1, 2016).

Notes: Composite grades are length weighted to interval width. Composite true widths range from 78% to 97% of the reported interval.

The results from all infill Phase III drill holes at Pine Tree-Josephine showed strong correlation with the geology documented during the preceding Phase I and II diamond drilling programs and the historical RC drilling campaigns, and geological analysis of the Pine Tree-Josephine Deposit. In addition, all four of the deep drill holes successfully intersected the same mineralized structure as the shallow holes, demonstrating significant depth extension to the main Pine Tree-Josephine gold-bearing zone (Figure 10.7).

10.2.2 Queen Specimen Drilling

Drilling programs at the Queen Specimen Deposit were completed in 2015-2016 and in 2017-2018. The results from each of these two drilling programs are summarized below.

10.2.2.1 Queen Specimen Drilling 2015-2016

Following completion of the Phase III drilling program at Pine Tree-Josephine in 2015-2016, five diamond drill holes were completed 1 km to the north on the Queen Specimen Deposit. The collar locations are shown on Figure 10.8 and interpreted cross-sections are presented in Figures 10.9 and 10.10. Assay highlights are shown in Table 10.7.

FIGURE 10.8 2016 DRILL PROGRAM HOLES COMPLETED IN QUEEN SPECIMEN AREA, PLAN VIEW

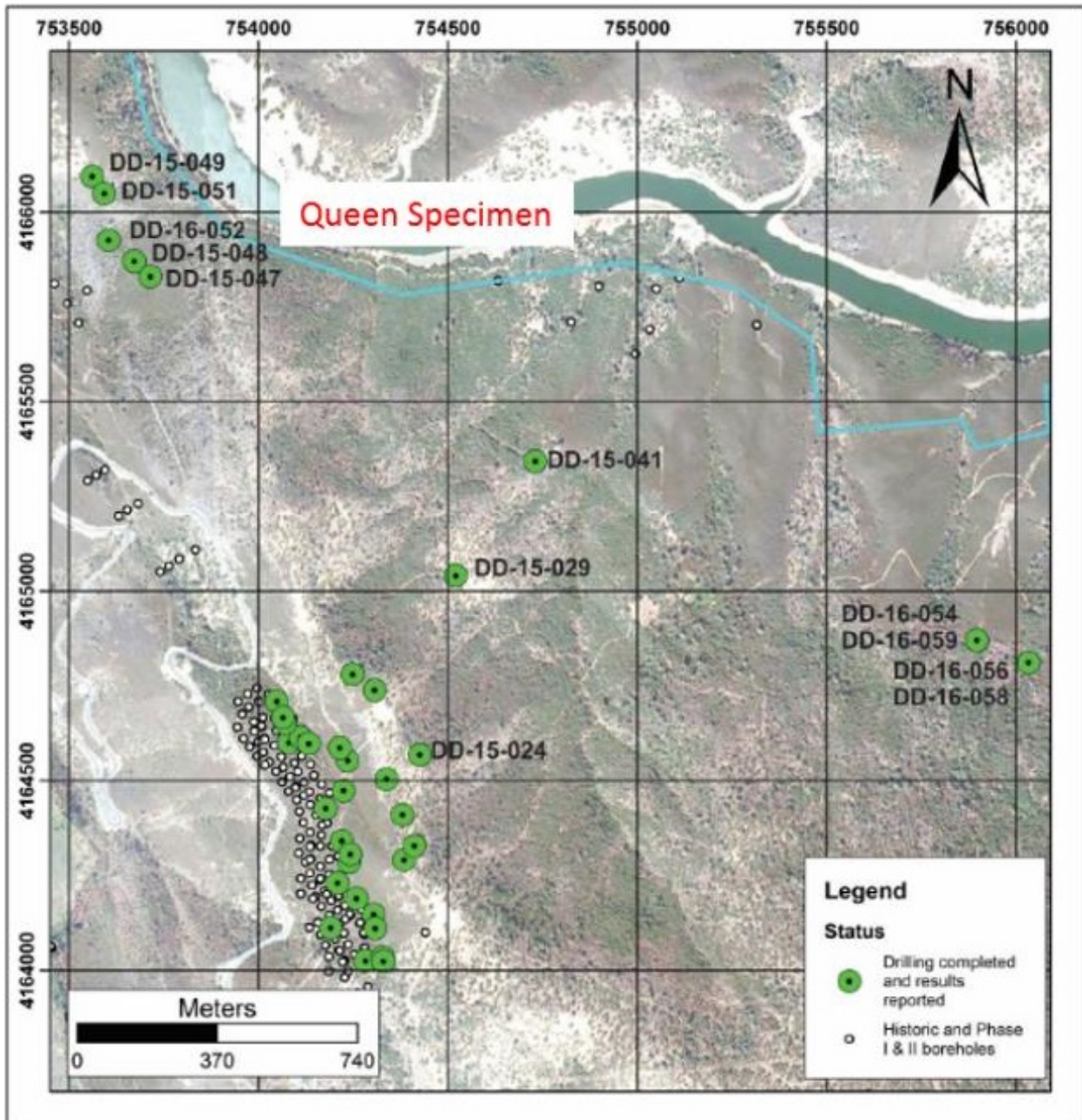

Source: California Gold press release (October 3, 2016)

FIGURE 10.9 QUEEN SPECIMEN 2016 GEOLOGICAL VERTICAL CROSS-SECTIONAL PROJECTION 26,700 N

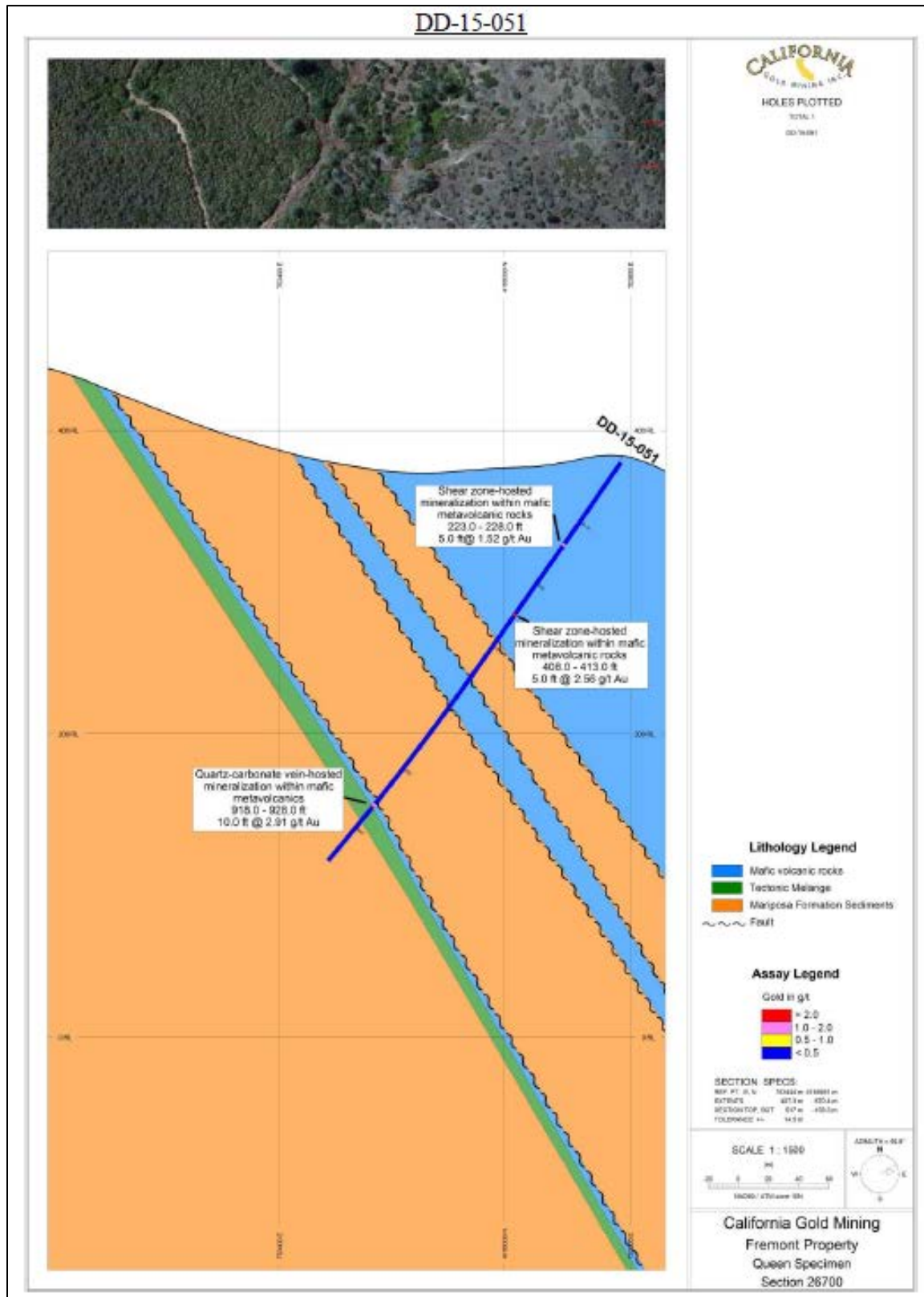

Source: California Gold press release (October 3, 2016)

FIGURE 10.10 QUEEN SPECIMEN 2016 GEOLOGICAL VERTICAL CROSS-SECTIONAL PROJECTION 26,400 N

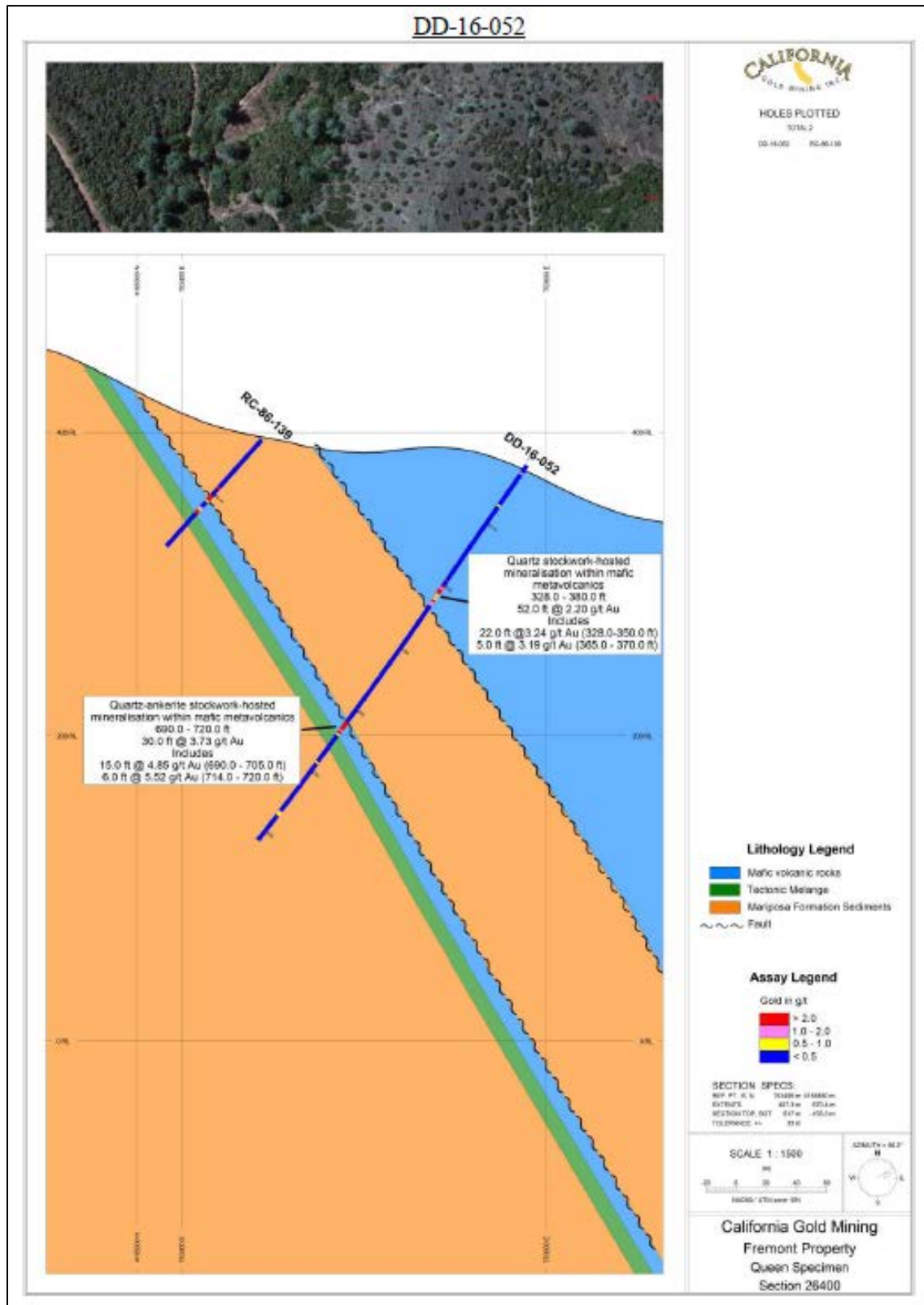

Source: California Gold press release (October 3, 2016).

TABLE 10.7
QUEEN SPECIMEN 2016 DRILLING HIGHLIGHTS

Drill Hole ID	Azimuth (deg)	Dip (deg)	Total Depth (m)	From (m)	To (m)	Interval (m)	Au (g/t)
DD-15-051	240	-55	328.6	68.0	69.5	1.5	1.52
and				124.4	125.9	1.5	2.56
and				279.8	282.9	3.1	2.91
DD-16-052	240	-55	307.5	100.0	115.8	15.8	2.20
including				100.0	106.7	6.7	3.24
including				111.3	112.8	1.5	3.19
and				210.3	219.5	9.2	3.73
including				210.3	214.9	4.6	4.85
including				217.6	219.5	1.9	5.52

Source: California Gold press release (October 3, 2016).

Notes: Composite grades are length weighted to interval width. Composite true widths are estimated to be 70% of the reported interval.

10.2.2.2 Queen Specimen Drilling 2017-2018

21 drill holes were completed at the Queen Specimen Deposit in 2017-2018. Drill hole collar locations and cross-sectional projections are shown in Figures 10.11 to 10.13. Drill hole orientations, depths and selected assay highlights are listed in Table 10.8.

FIGURE 10.11 2018 DRILL PROGRAM HOLES IN QUEEN SPECIMEN AREA, PLAN VIEW

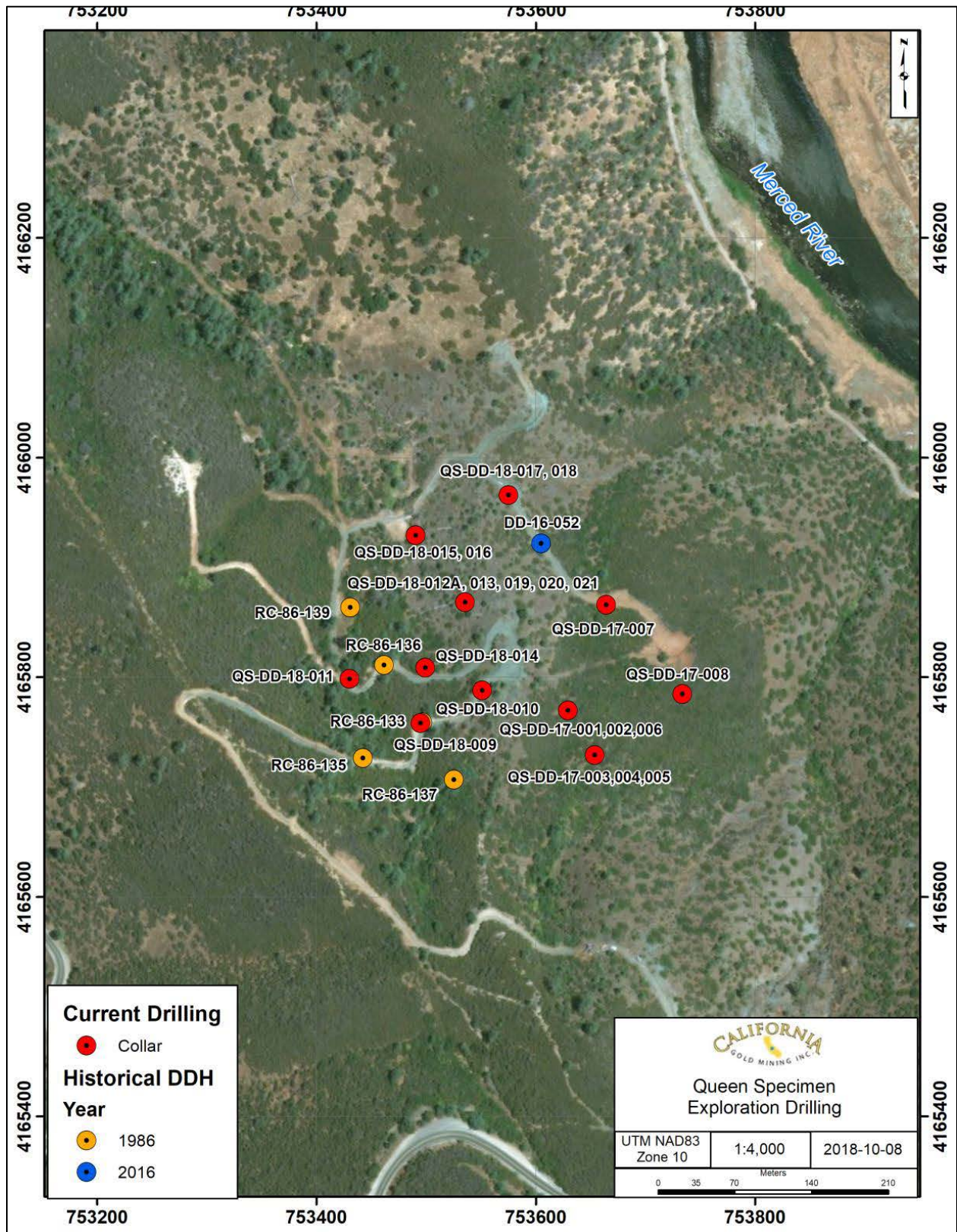

Source: California Gold (press release dated November 5, 2018)

**FIGURE 10.12 QUEEN SPECIMEN 2018 VERTICAL CROSS SECTION PROJECTIONS
26,000 N AND 26,100 N**

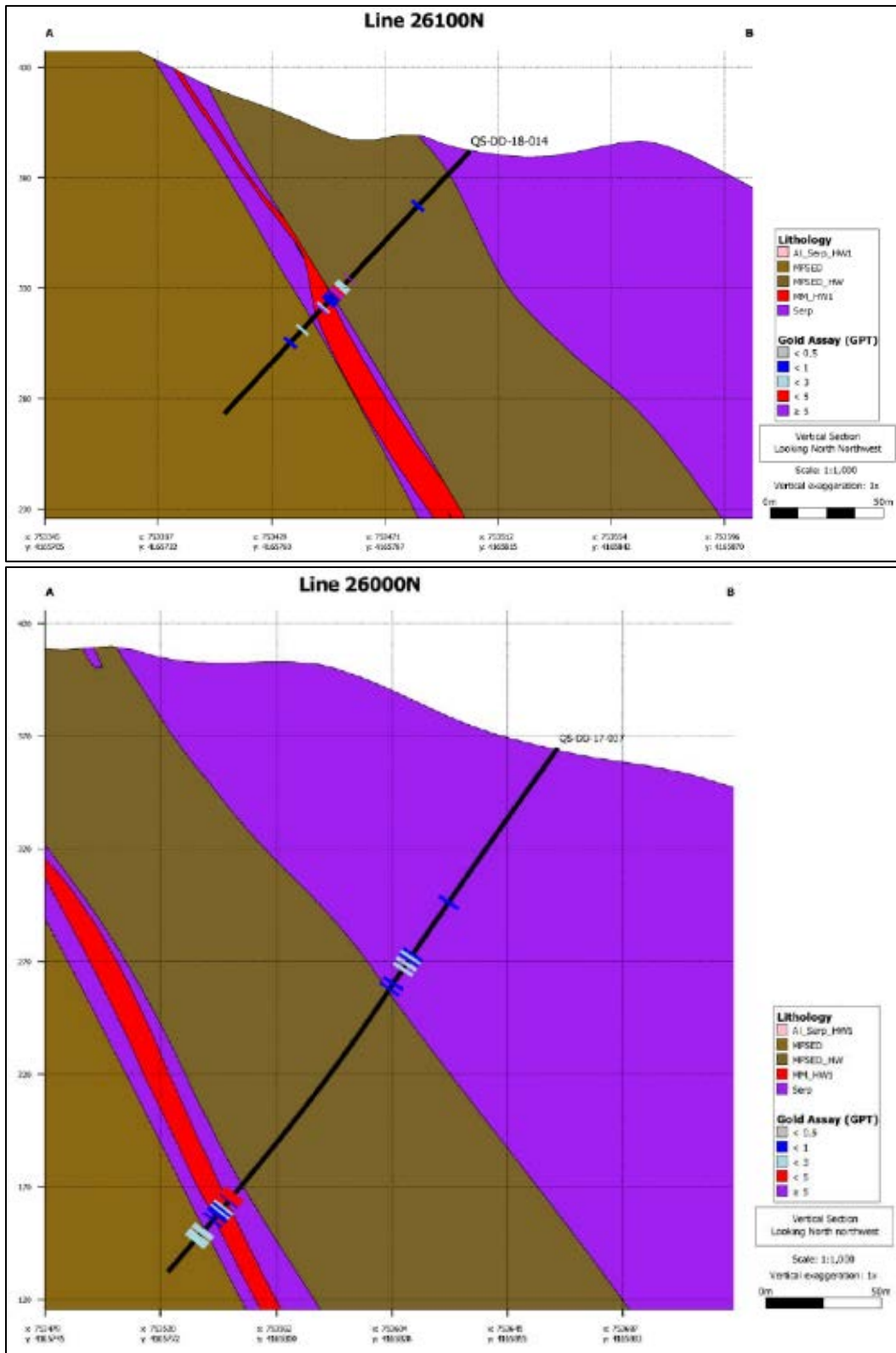

Source: California Gold (press releases dated 2018).
View looking north-northwest.

**FIGURE 10.13 QUEEN SPECIMEN 2018 VERTICAL CROSS-SECTIONAL PROJECTIONS
26,200 N AND 26,400 N**

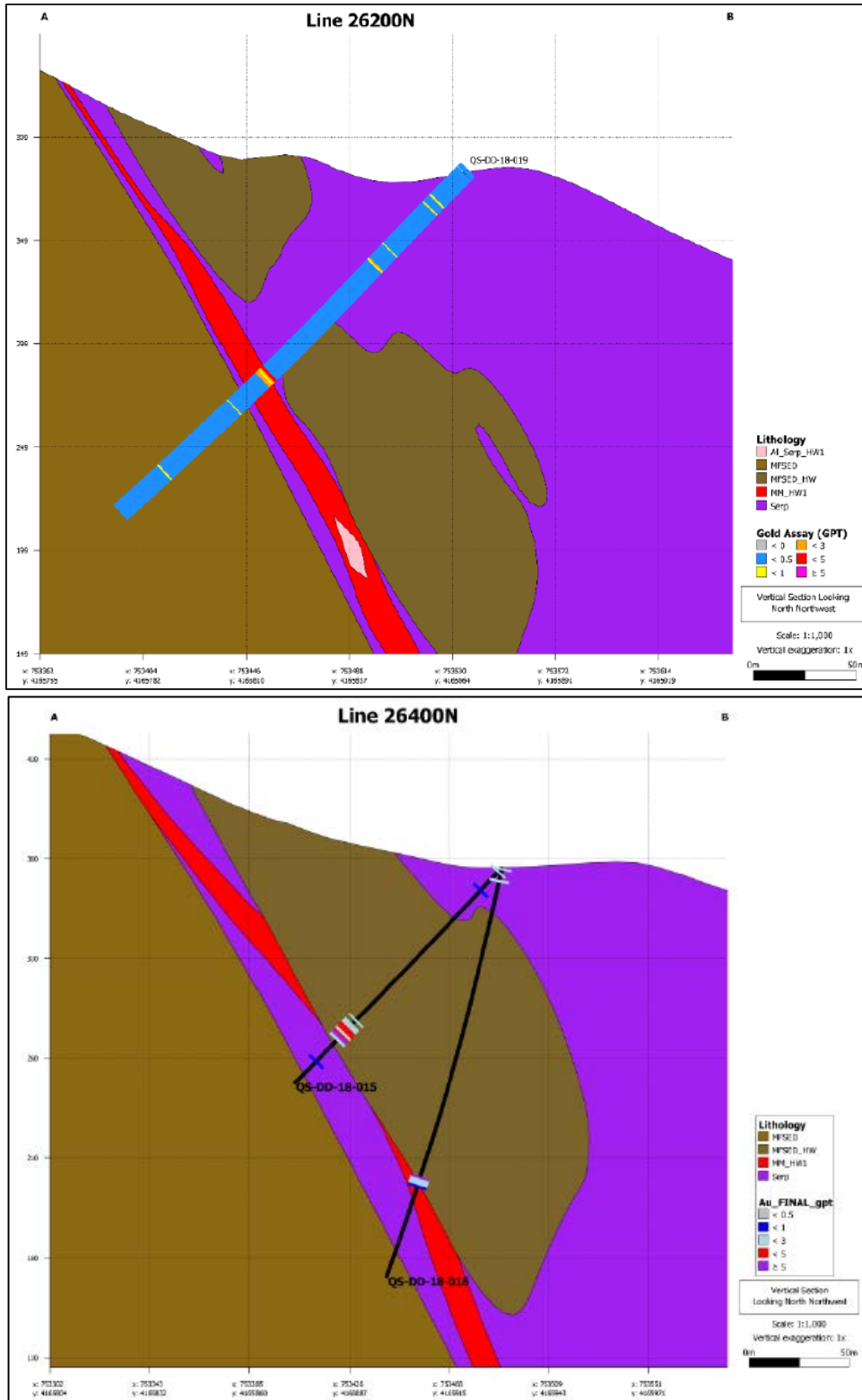

Source: California Gold (press releases dated 2018)

Note: View looking north-northwest.

TABLE 10.8
QUEEN SPECIMEN 2017-2018 DRILLING ASSAY HIGHLIGHTS (3 PAGES)

Drill Hole ID	Section (m N)	Azimuth (deg)	Dip (deg)	Total Depth (m)	From (m)	To (m)	Length (m)	Au (g/t)
QS-DD-17-001	25,800	235	-63	228.0	183.0	188.4	5.4	1.77
including					184.1	186.2	2.1	3.42
QS-DD-17-002	25,800	235	-74	259.0	218.5	227.7	9.2	1.14
including					220.1	224.6	4.5	1.92
QS-DD-17-004	25,600	235	-60	232.0	194.2	198.4	4.2	1.56
including					194.2	196.0	1.8	2.97
QS-DD-17-005	25,600	235	-72	292.3	237.4	245.1	7.7	1.23
including					239.0	240.5	1.5	3.01
QS-DD-17-006	25,800	235	-48	202.0	66.8	71.0	4.2	0.88
and					157.6	167.9	10.4	0.94
including					157.6	162.5	4.9	1.11
QS-DD-17-007	26,000	235	-55	287.0	110.3	119.5	9.2	1.51
and					241.3	270.4	29.1	1.25
including					242.3	246.3	4.00	4.12
and including					249.6	257.8	8.2	0.92
and including					262.7	269.6	6.9	1.51
QS-DD-17-008	25,600	235	-55	314.9	270.2	275.2	5	0.94
including					270.2	270.9	0.7	1.92
including					273.7	275.2	1.5	1.65
and					285.9	298.1	12.2	1.42
including					285.9	287.4	1.5	2.52
and					287.4	289.0	1.6	3.05
QS-DD-18-009	26,000	235	-48	122.8	68.0	98.2	30.2	1.21
including					68.0	77.3	9.3	2.37
including					69.5	72.5	3.0	3.67
and including					94.5	98.2	3.7	2.71
including					95.1	96.6	1.5	3.87
including					96.6	98.2	1.6	2.36
QS-DD-18-010	26,000	235	-45	161.0	115.2	143.6	28.4	1.22
including					115.2	121.5	6.3	2.66
and including					132.0	143.6	11.6	1.37
including					137.5	142.0	4.5	2.39
QS-DD-18-012A	26,200	235	-52	192.6	62.8	67.4	4.6	1.47
and					142.3	146.9	4.6	3.26
including					142.3	143.9	1.6	3.65
and including					143.9	145.7	1.8	4.62

TABLE 10.8
QUEEN SPECIMEN 2017-2018 DRILLING ASSAY HIGHLIGHTS (3 PAGES)

Drill Hole ID	Section (m N)	Azimuth (deg)	Dip (deg)	Total Depth (m)	From (m)	To (m)	Length (m)	Au (g/t)
and					163.4	166.4	3.00	0.59
QS-DD-18-013	26,200	235	-75	238.7	8.5	11.6	3.1	1.01
and					66.5	80.2	13.7	1.64
including					66.5	69.5	3.0	1.11
and including					71.0	74.1	3.1	4.37
and including					77.1	80.2	3.1	1.73
and					185.3	196.0	10.7	4.08
including					191.1	192.6	1.5	20.75
and					202.1	214	11.9	0.52
and					221.6	229.2	7.6	0.57
QS-DD-18-014	26,100	235	-48	160.3	77.4	96.7	19.3	2.06
including					77.4	77.9	0.5	9.14
including					81.2	82.3	1.1	2.09
including					84.4	87.8	3.4	5.11
including					95.7	96.7	1.0	6.31
and					108.4	109.6	1.2	1.24
QS-DD-18-015	26,400	220	-45	154.5	108.5	123.4	14.9	4.67
including					114.6	120.1	5.5	3.11
and including					120.1	121.9	1.8	22.9
QS-DD-18-016	26,400	220	-75	214.9	160.9	167.0	6.1	2.70
including					160.9	162.2	1.3	7.97
QS-DD-18-019	26,200	245	-45	237.7	62.8	65.8	3.0	0.62
including					64.3	65.1	0.8	1.25
and					138.5	143.7	5.2	2.29
including					138.5	140.9	2.4	3.26
QS-DD-18-020	26,200	250	-64	210.9	19.5	20.6	1.1	0.70
and					30.9	32.5	1.6	2.12
and					65.2	68.3	3.1	6.14
including					65.2	66.8	1.6	10.3
and					72.9	75.3	2.4	1.50
including					74.3	75.3	1.0	2.24
and					163.7	173.4	9.7	1.25
including					163.7	165.2	1.5	2.84
and including					166.3	167.2	0.9	1.62
and including					171.8	172.8	1.0	1.96
and					190.2	192.6	2.4	1.41
including					190.2	191.7	1.5	1.66

TABLE 10.8
QUEEN SPECIMEN 2017-2018 DRILLING ASSAY HIGHLIGHTS (3 PAGES)

Drill Hole ID	Section (m N)	Azimuth (deg)	Dip (deg)	Total Depth (m)	From (m)	To (m)	Length (m)	Au (g/t)
QS-DD-18-021	26,200	215	-55	242.9	53.6	57.0	3.4	10.6
including					54.3	55.5	1.2	27.6
and					61.9	71.0	9.1	1.23
including					62.6	63.4	0.8	2.68
and including					64.9	66.1	1.2	2.22
and including					70.4	71.0	0.6	2.04
and					152.6	163.4	10.8	1.56
including					153.4	154.5	1.1	1.62
and including					156.5	157.9	1.4	3.49
and including					159.6	160.4	0.8	4.13
and					166.7	176.8	10.1	3.27
including					167.6	171.3	3.7	6.13
and including					174.7	175.6	0.9	4.07
and					180.4	181.6	1.2	2.06

Source: California Gold press releases 2017-2018 (available at www.SEDAR.com).

Notes: Composite grades are length weighted to interval width.

True widths generally range from 60%-95% of the reported intervals.

The Queen Specimen drill holes were designed to test the continuity of lithology, structures, and mineralization to the north along strike of the Pine Tree–Josephine Deposit. The drilling returned significant gold mineralized intercepts. In general, the same lithological sequence was observed in these drill holes as in the previously completed drill holes in the Pine Tree–Josephine Deposit, including a sequence of metavolcanic mafic rocks overlying a melange of serpentized ultramafic rocks. These rock units are separated from the underlying metasedimentary rocks of the Mariposa Formation by a zone of highly sheared and serpentized phyllonite, characteristic of the Melones Shear Zone. In addition to the sequence noted above, a second occurrence of fault-emplaced Mariposa Formation sedimentary rocks is apparent within the hanging-wall mafic metavolcanic rocks. This stratigraphic repetition may reflect thrust faulting or folding associated with dextral movement along the Melones Shear Zone, evidence for which was observed in the historical airborne magnetic data acquired for the Fremont Project.

11.0 SAMPLE PREPARATION, ANALYSIS AND SECURITY

The following section discusses sampling conducted by Golden Bell (1985 to 1986 RC drilling), Precision Gold LLC's (2008 tailings sampling), California Gold (2013 to 2018 diamond drilling), and Stratabound (2022 trenching) at the Fremont Gold Property.

11.1 HISTORICAL SAMPLE PREPARATION, ANALYSES AND SECURITY

11.1.1 Goldenbell Reverse Circulation (1985 to 1986)

Drill cuttings from Goldenbell's RC holes, completed in 1985 and 1986, were blown out of the first 3.05 m (10 ft) of each hole and collected as a pie sample in rubber dishwashing tubs placed alongside the hole collar. Cuttings were driven up the center tube of the drill stem by exhaust air from the hammer or bit and directed to a cyclone for air-solids separation. The solids from the cyclone underflow cascaded through a two-tier Jones riffle splitter, quartering the sample. Samples were collected every 1.52 m (5 ft).

The one-quarter samples from the Jones splitter were placed in a fabric sample bag marked with sample number, hole number and footage and transported to the sample logging station. At the logging station, the samples were dried (if wet), weighed and split using a Jones riffle splitter into "assay" and "geology" samples. The hole number, sample number, footage and weights were recorded on "split sheets" and entered into a computer. The assay samples were sent to the lab for analysis and a small handful of cuttings were taken from the geology samples and washed in a small pie plate. Each sample was then examined under a binocular microscope and rock type, colour and alteration were recorded on "Geoform" software using the Geolog code. California Gold photographed the RC chip trays from 1985-1986. The three-quarter samples were collected in burlap sacks and stored on the drill pads. Select three-quarter samples were subsequently used for metallurgical test work.

There is no record in the available reports of the on-site security methods employed during the drilling program and at the sample logging station.

Following collection and logging, the samples were sent to Bondar Clegg & Company Ltd. ("Bondar Clegg") in North Vancouver, BC. Bondar Clegg, acquired by ALS Minerals ("ALS") in 2001, was established in 1962 and was a major provider of analytical services to the mineral industry, with laboratory facilities in Canada, the USA, Mexico, Ecuador, Peru, Brazil, Bolivia, Chile and Argentina.

When received by Bondar Clegg, the samples were dried (if wet), crushed, and split. The size of the split is not recorded. The crushed split was pulverized to -150 mesh and rolled. Gold and limited silver assay were performed on all samples, with certain samples screened and "metallic" gold analyses completed.

11.1.2 Precision Gold LLC Tailings Sampling (2008)

Tubes from the 2008 tailings sampling program (Smith, 2008), were labelled with the drill hole number and depth, and then placed in the geologist's truck for delivery to the logging and sampling site. When delivered, each boring's acetate core barrel was wiped clean, split and placed on clean plastic sheeting. One-half of the acetate core barrel was then carefully removed before cutting away some of the core material with a putty knife, thereby exposing the internal layering of the remaining core. The removed core material was divided into 3.05 m (10 ft) intervals and placed into appropriately labelled plastic one-gallon Ziploc bags and the remaining exposed core was photographed and described on a geologic boring log. On completion of logging, the remaining core material was also divided into 3.05 m sample intervals and added to the previously removed and bagged core material. Sample intervals that included the tailings/soil interface were carefully split into separate samples at the interface, resulting in a shorter sample interval.

A Company geologist delivered the samples to Inspectorate America Corporation ("Inspectorate" (rebranded as Bureau Veritas on October 1, 2018)) in Sparks, Nevada for laboratory analysis. The drill hole samples were assayed for gold using standard fire assay methods with an atomic absorption finish. Samples with assay results greater than 4 ppm gold were re-assayed using a gravimetric finish.

The Inspectorate lab in Sparks, Nevada was ISO 9001:2008 certified, participated in round robin testing, and hired BC Certified Assayers, experienced technicians, and chemists to complete all analytical work.

11.1.3 California Gold Core Drilling (2013 to 2018)

HQ drill core was boxed by the drill helper on an on-going basis and delivered from the drill sites at the end of shift to the drill core logging and cutting facilities located in California Gold's office-warehouse, adjacent to Highway 49. The drill core was securely stored in the warehouse until logged and sampled by the geologists and geotechnicians, respectively. The office-warehouse was located in a secure fenced area and locked when unoccupied. Drill core was rolled into alignment where possible, washed, and inspected for footage errors or out-of-sequence pieces. The drill core was then logged for lithology, alteration, structure, mineralization, core recovery, and rock quality designation ("RQD"), before being photographed.

Drill core was sampled over the entire length of the drill hole. Samples ranged from 0.61 m (2 ft) (in quartz veins) to 2.43 m (8 ft), with the majority of the samples being 1.52 m (5 ft). Sample intervals honoured geological contacts and were marked on the core and on the boxes. Pre-printed sample tags were utilized, with one part left in the sample binder as a record and the other half placed with the half drill core sample in a numbered sample bag. Aluminum tags with the unique sample number and sample footage were stapled into the drill core box. Drill core was sawn lengthwise, with the left-half becoming the sample and the right-half returned to the drill core box for reference purposes. Intervals that were too soft or broken to saw were separated in half using a putty knife.

After samples were split and bagged, they were put into rice bags and closed with a security seal for transportation to American Assay Laboratories ("AAL"), in Sparks, Nevada. The samples were

collected from California Gold personnel at the locked facility by a contractor and transported directly to AAL. AAL, an ISO/IEC 17025:2005/2017 accredited commercial geochemical laboratory, is independent of California Gold and Stratabound. AAL checked each bag for the security seal and sent the seal numbers back to the site manager for confirmation.

Drill core samples were dried and crushed to 90% minus 10 mesh. A rotary splitter was used to obtain a 500 g sample, which was then pulverized and further reduced to a 30 g sample. From 2013 to the start of the 2015 program, samples with strong mineralization were analyzed by screened metallics fire assay. The screened metallics were collected as the plus fraction from a 150 mesh screen at the laboratory. The plus 150 mesh fraction was fire assayed in its entirety. Two separate fire assays of the minus 150 mesh fraction were performed and arithmetically averaged. The minus and plus 150 mesh results were then combined for a total screened metallics fire assay. For the remainder of the 2015 to 2018 programs, a 30 g sample was analyzed by fire assay with ICP-OES or gravimetric finish. Approximately 10% of all drill core samples were subjected to repeat analysis.

11.2 STRATABOUND PINE TREE-JOSEPHINE TRENCHING (2022)

A channel sampling program was undertaken along the Pine Tree-Josephine drill road system in May of 2022, to further evaluate the oxide mineralization exposed in this Mineral Resource area. 14 sections of the road network, with mostly continuous outcrop exposure of strongly oxidized bedrock and regolith, were channel sampled in 3.05 m (10 ft) increments.

Continuous sections of oxidized outcrop were mapped and channel sampled. Outcrop with soft and deeply weathered exposures were sampled using a geo pick and pan, and hard outcrops were sampled using hammer and chisel. A total of 127 channel samples were collected during the trenching program. The start and end points of each channel sample were surveyed with a hand-held Garmin 64 GPS and all samples were photographed at the site of collection.

11.3 BULK DENSITY DATA

Specific gravity of various rock types and vein mineralization was measured by California Gold using a water immersion method. A total of 1,045 specific gravity measurements were taken. A verification program of California Gold's specific gravity data was carried out in 2016, with approximately 14% of the data (143 out of 1,045 samples) sent for verification testing at ALS in Reno, Nevada using pycnometer method on pulp samples (method OA-GRA08b). Samples from 14 drill holes completed in the Pine Tree-Josephine area were included in verification testing. Aside from the very occasional gross outliers, pycnometer results generally compare well with California Gold's field-measured results (Figure 11.1), although the ALS determinations are generally higher than the original results.

FIGURE 11.1 CALIFORNIA GOLD SPECIFIC GRAVITY VERIFICATION AT ALS

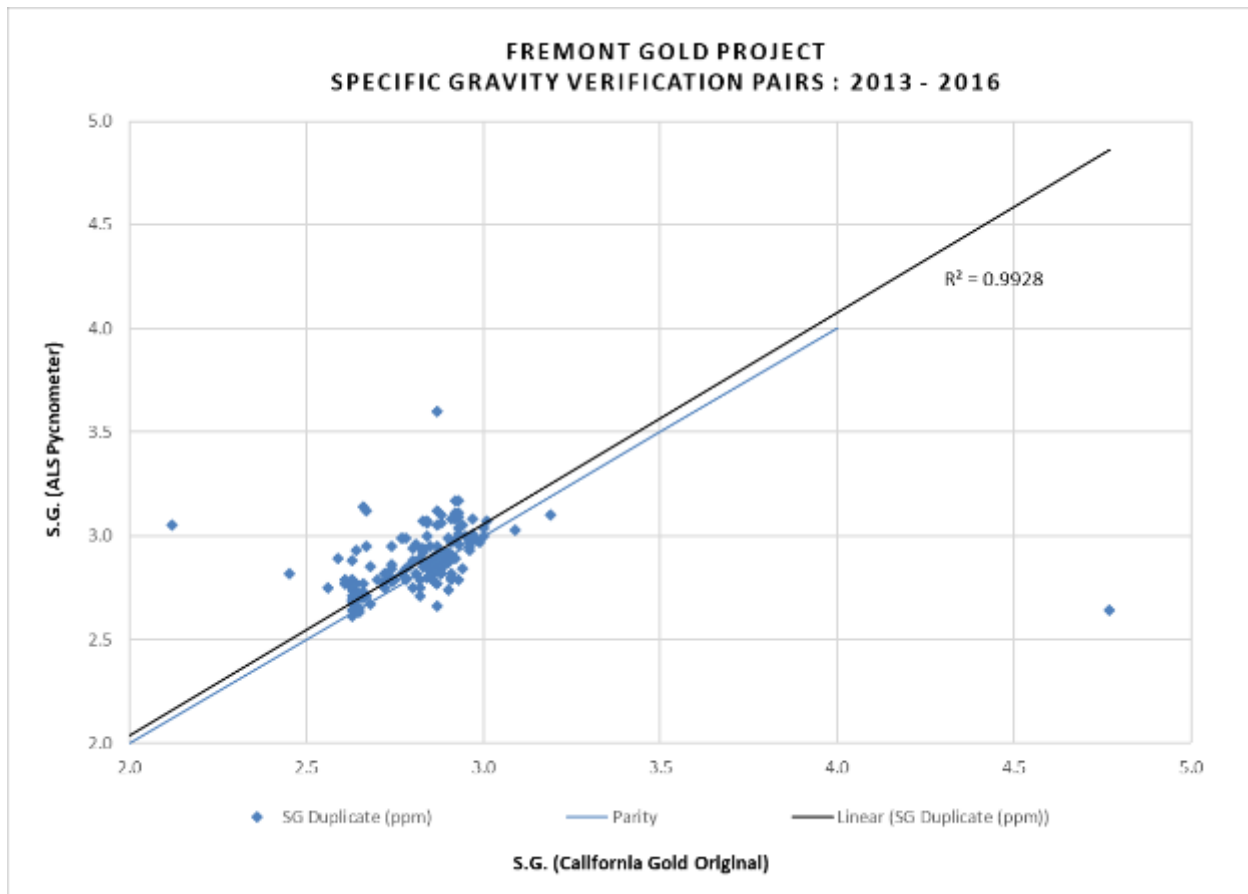

11.4 HISTORICAL QUALITY ASSURANCE/QUALITY CONTROL REVIEW

11.4.1 Goldenbell RC (1985 to 1986)

Mr. Alfred A. Burgoyne, P.Eng., carried out a review of the work undertaken by Goldenbell at the Property from 1984 to 1986 (Burgoyne, 2013). Mr. Burgoyne reports that “it is clear that Goldenbell monitored the quality of the reverse circulation drilling samples and analytical database through ‘reported’ check assays (duplicates) and re-analyses of samples. This was verified by checking assay certificates and the “Geologs” which tie the sample drill hole and interval to the sample number and assay.” Burgoyne, however, was unable to establish the quantity of duplicates taken or if blanks were inserted into the sample stream, and concluded that a formal Quality Assurance/Quality Control (“QA/QC”) program, that would meet generally accepted industry standards, was not undertaken. Consequently, California Gold drilled a number of twin drill holes (14 in total) at the Pine Tree-Josephine Deposit to confirm the mineralization reported in Goldenbell’s historical RC holes. Results of the twin drilling program are discussed in Section 12.4.

11.4.2 Precision Gold LLC Tailings Sampling (2008)

Precision Gold's 2008 tailings sampling program included the insertion of "six certified reference materials ("CRM") of known gold value and four blanks of quartz sand" (Burgoyne, 2013). However, the QA/QC data results from the 2008 drill program have not been reviewed by the Authors.

11.4.3 California Gold Core Drilling (2013 to 2018)

QA/QC protocol at the Property throughout 2013 to 2018 comprised the routine insertion of CRMs and blanks into the sample stream at a frequency of one CRM every 20 samples and one blank every 10 samples.

11.4.3.1 Performance of Certified Reference Materials

A total of six different CRMs, over a range of gold grades, were inserted into the sampling sequence throughout the 2013 to 2018 programs. The CRMs were sourced from Shea Clark Smith/MEG, Inc. of Reno, Nevada and included: the MEG-Au.13.02 (mean value of 0.746 ppm Au), MEG-Au.11.17 (mean value of 2.693 ppm Au), MEG-S107006x (mean value of 2.850 ppm Au), MEG-LWA-25 (mean value of 6.887 ppm Au) and MEG-Au.11.34 (mean value of 2.113 ppm Au) CRMs.

Criteria for assessing CRM performance are as follows: data falling within ± 2 standard deviations from the accepted mean value pass and data falling outside ± 3 standard deviations from the accepted mean value fail. A number of misallocated samples were observed in the data CRM data, and subsequently corrected by the Author.

There were 203 MEG-Au.13.02 and 36 MEG-S107006X samples to analyze in the 2013-2018 dataset and all data fell within ± 3 standard deviations from the mean (Figures 11.2 and 11.4).

The remaining CRMs, MEG-Au.11.17 (n=198), MEG-LWA-25 (n=210) and MEG-Au.11.34 (n=154), returned a majority of results within ± 3 standard deviations from the mean (Figures 11.3, 11.5 and 11.6). A single failure was noted for the 194 MEG-Au.11.17 CRM, which fell below -3 standard deviations from the mean with a value of 0.994 ppm Au. A high bias was also observed in the MEG-Au.11.17 CRM data. A single failure was also noted for the MEG-LWA-25 CRM, with the failed sample falling above +3 standard deviations from the mean with a value of 8.16 ppm Au. Two failures were observed in the 194 MEG-Au.11.34 CRM data, with both samples falling above +3 standard deviations from the mean with values of 5.554 and 3.22 ppm Au.

The Author considers that the CRM data demonstrates acceptable accuracy in the 2013 to 2018 Fremont Gold data.

FIGURE 11.2 PERFORMANCE OF MEG-AU.13.02 CRM FOR AU

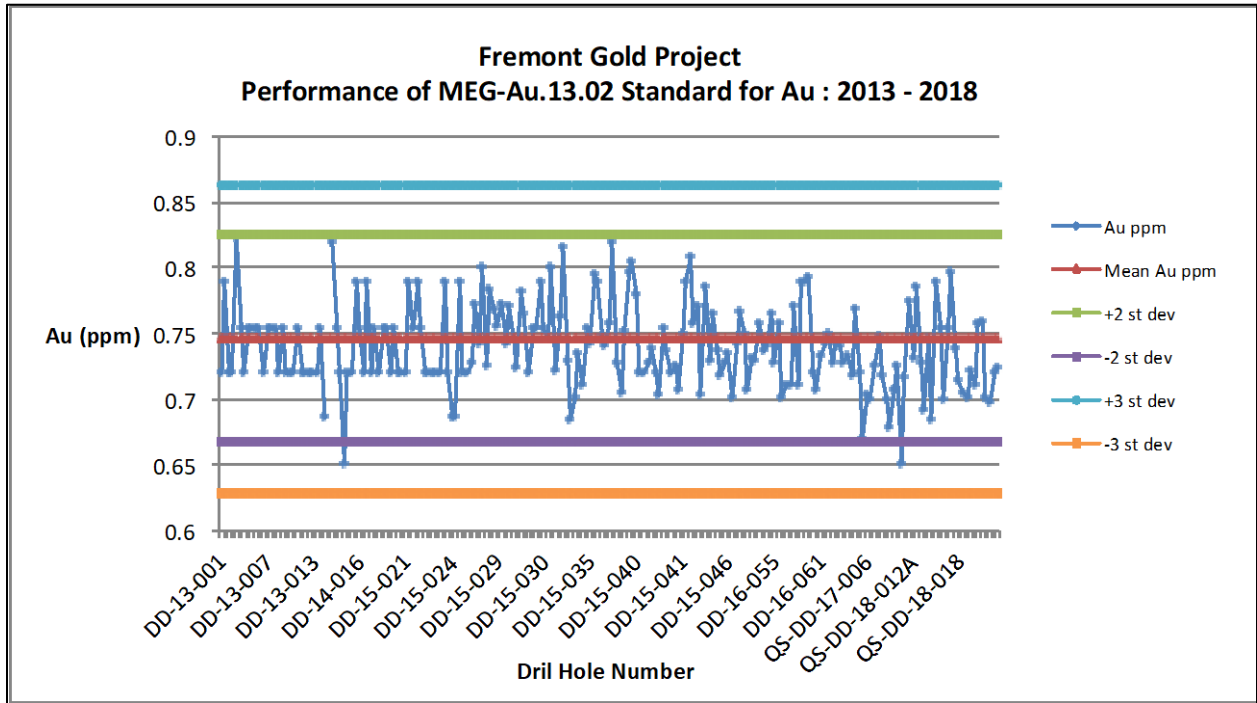

FIGURE 11.3 PERFORMANCE OF MEG-AU.11.17 CRM FOR AU

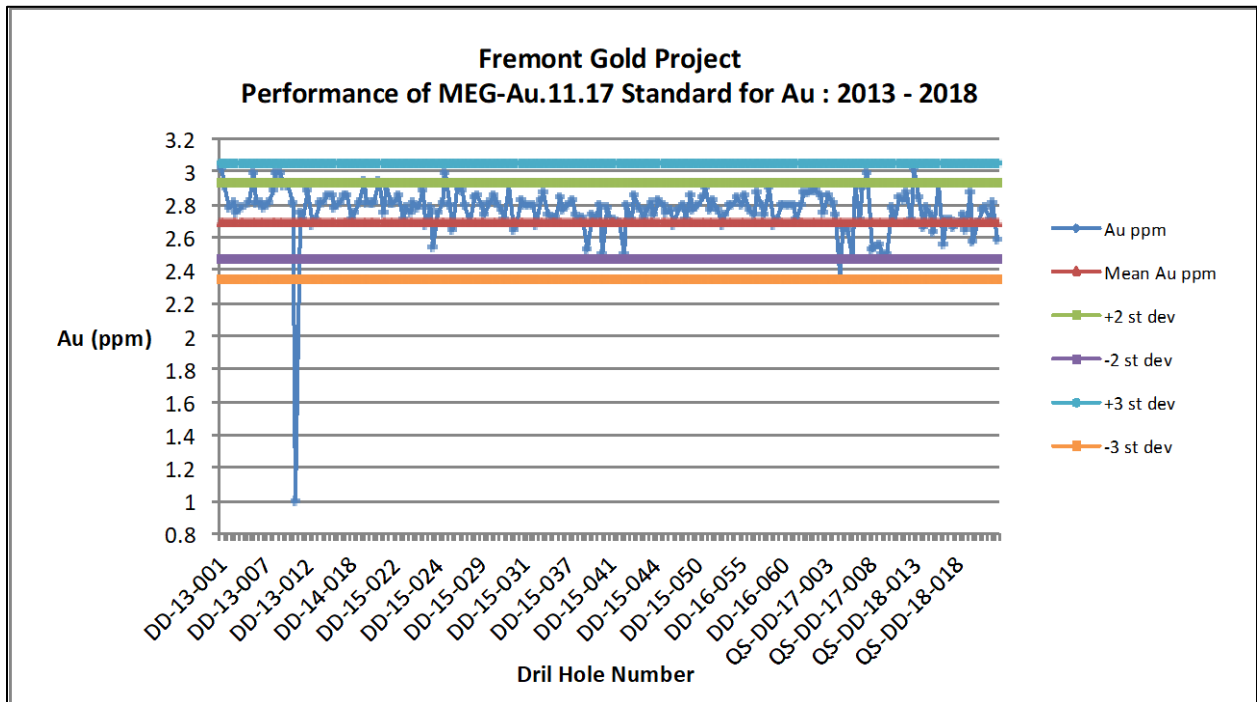

FIGURE 11.4 PERFORMANCE OF MEG-S107006X CRM FOR AU

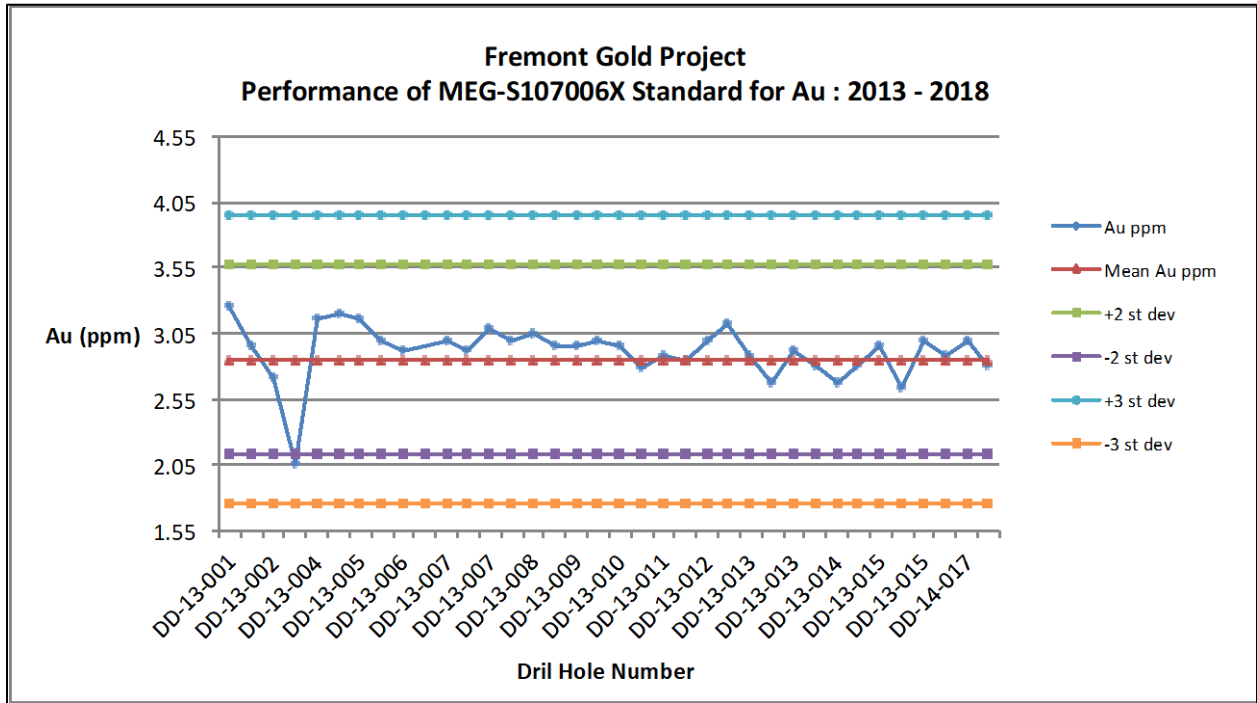

FIGURE 11.5 PERFORMANCE OF MEG-LWA-25 CRM FOR AU

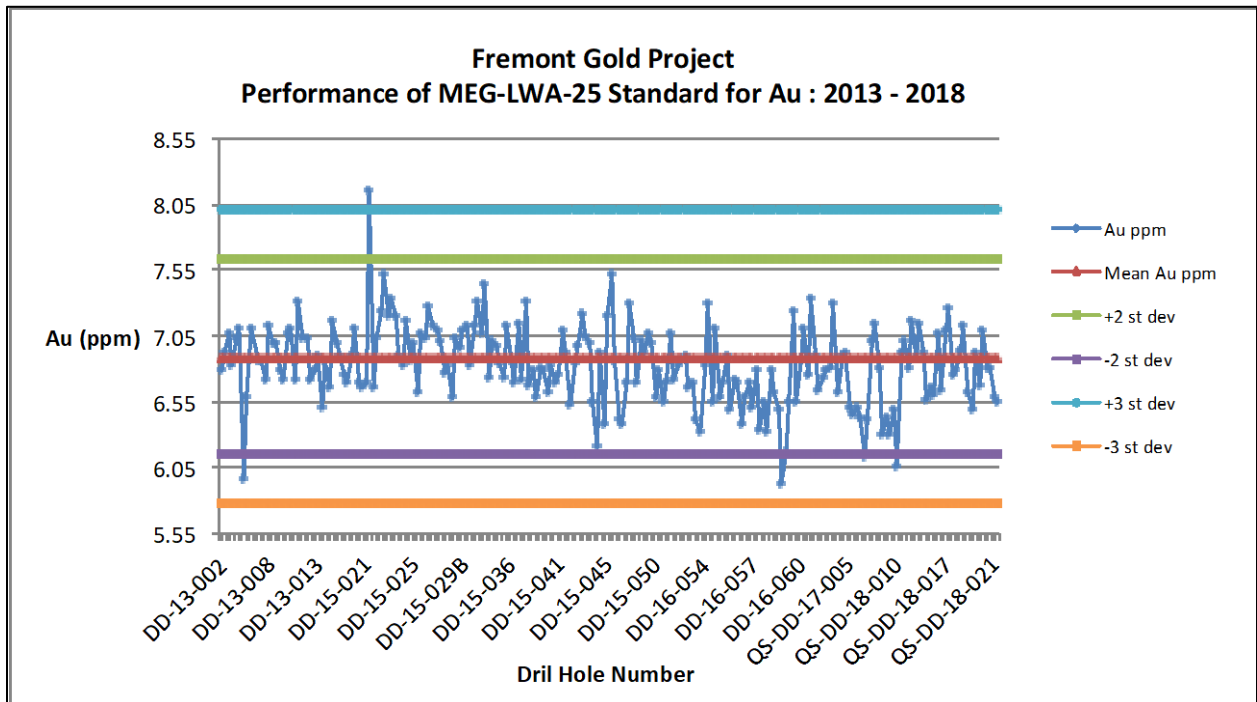
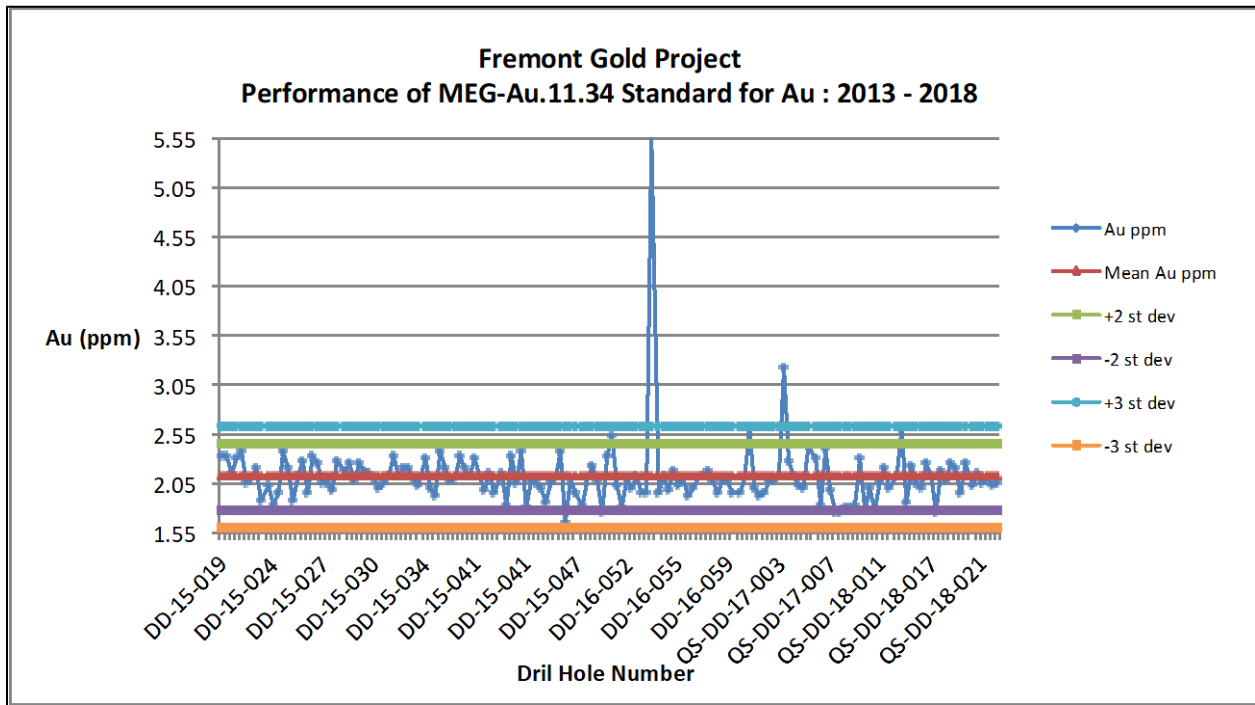

FIGURE 11.6 PERFORMANCE OF MEG-AU.11.34 CRM FOR AU



11.4.3.2 Performance of Blank Material

Blank material was sourced on the Property from slate or basalt previously analyzed as blank. All blank data for Au were reviewed by the Author. If the assayed value in the certificate was indicated as being less than detection limit, the value was assigned the value of one-half the detection limit for data treatment purposes. An upper tolerance limit of ten times the detection limit was set. A total of 2,897 blank samples were submitted from 2013 to 2018 at the Project.

The vast majority of data plots at or below the set tolerance limits for gold (Figure 11.7) and the Author does not consider the few outliers to be significant to the integrity of the data.

The Author does not consider contamination to be an issue for the 2013 to 2018 drill core Au assay data.

FIGURE 11.7 PERFORMANCE OF BLANK FOR AU

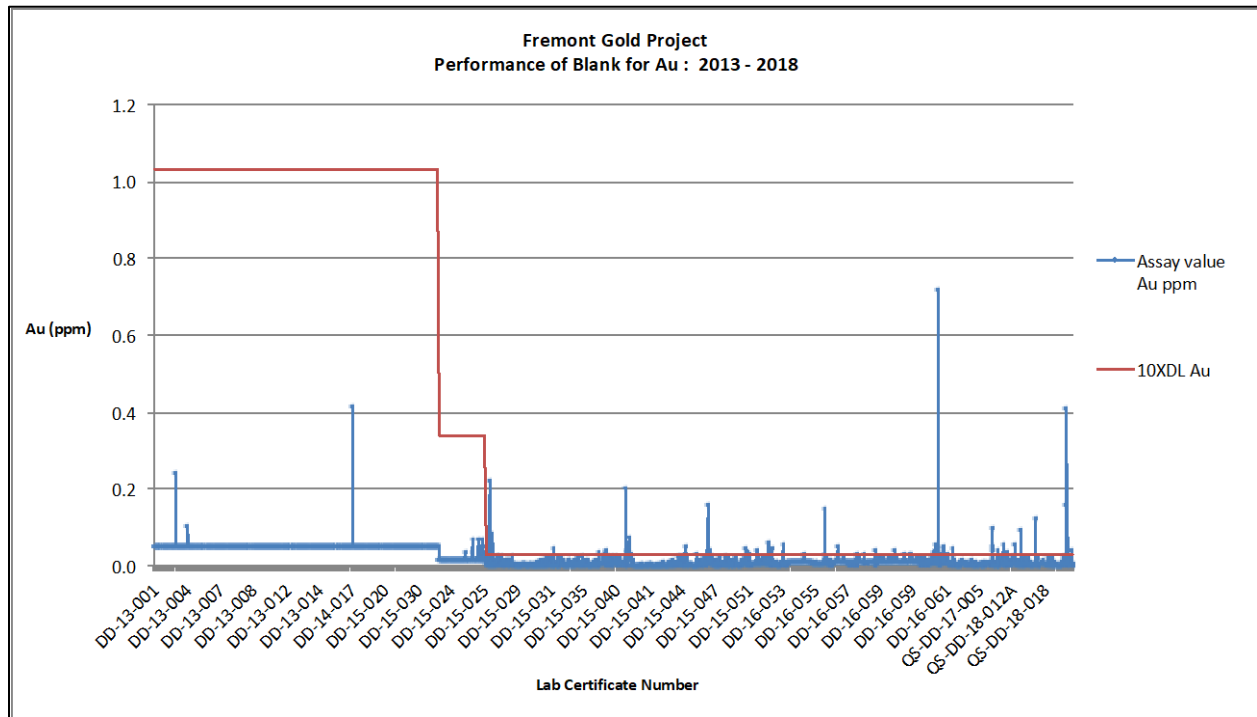

11.4.3.3 Performance of Lab Duplicates

California Gold did not insert field duplicates into the sample stream throughout the 2013 to 2018 sampling. However, the Author reviewed the laboratory duplicate data for Au, which comprised 2,121 duplicate pairs. All data for 2013 to 2018 sampling at the Project were scatter graphed (Figure 11.8) and a coefficient of determination (“R²”) of 0.9928 was estimated. The average coefficient of variation (“CV_{AV}”) was also used to estimate precision. Duplicate samples with combined means of <15 times the detection limit were excluded from the CV_{AV} data, to eliminate the level of influence of the data nearer the detection limit where higher-grade variations are more likely to occur, giving a CV_{AV} value of 12.7. The Author considers precision to be acceptable for this style of mineralization.

FIGURE 11.8 PERFORMANCE OF LAB DUPLICATES FOR AU

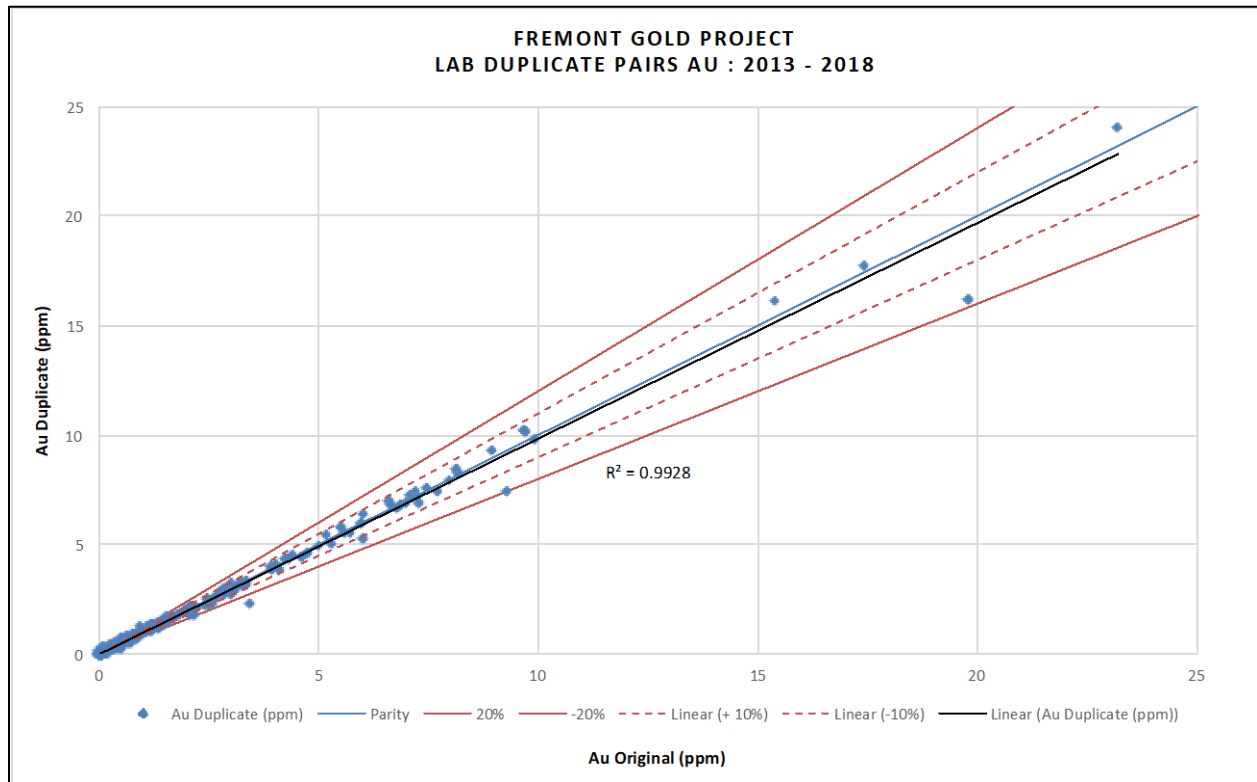

11.5 STRATABOUND QUALITY ASSURANCE/QUALITY CONTROL REVIEW

11.5.1 Stratabound Trenching (2022)

QA/QC protocol for trench sampling consisted of inserting CRMs, blanks and field duplicates into the trench sample stream, at a frequency of 5% each.

11.5.1.1 Performance of Certified Reference Materials

CRMs are inserted at a frequency of 5%, alternating three CRMs from OREAS North America Inc. of Mansfield, Ontario ("OREAS"). The three OREAS CRMs used included: OREAS 231, OREAS 233 and OREAS 236 and all CRMs are certified for gold.

Criteria for assessing CRM performance are as previously described in Section 11.4.3.1. The Author observed, and subsequently corrected, two misallocated samples in the CRM data.

There were seven data points to analyze for each of the CRMs and all data fell within acceptable limits (Figures 11.9 to 11.11). Slight high biases were noted for the OREAS 231 and 233 CRMs.

FIGURE 11.9 PERFORMANCE OF OREAS 231 CRM FOR AU

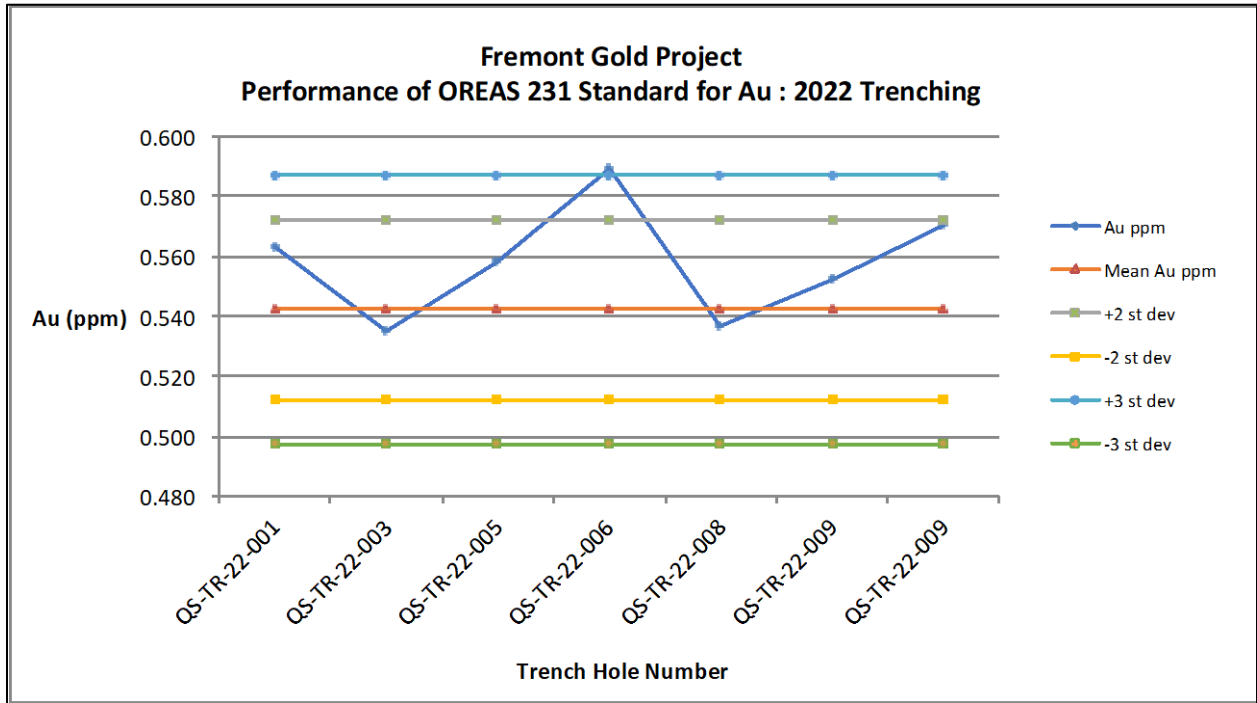

FIGURE 11.10 PERFORMANCE OF OREAS 233 CRM FOR AU

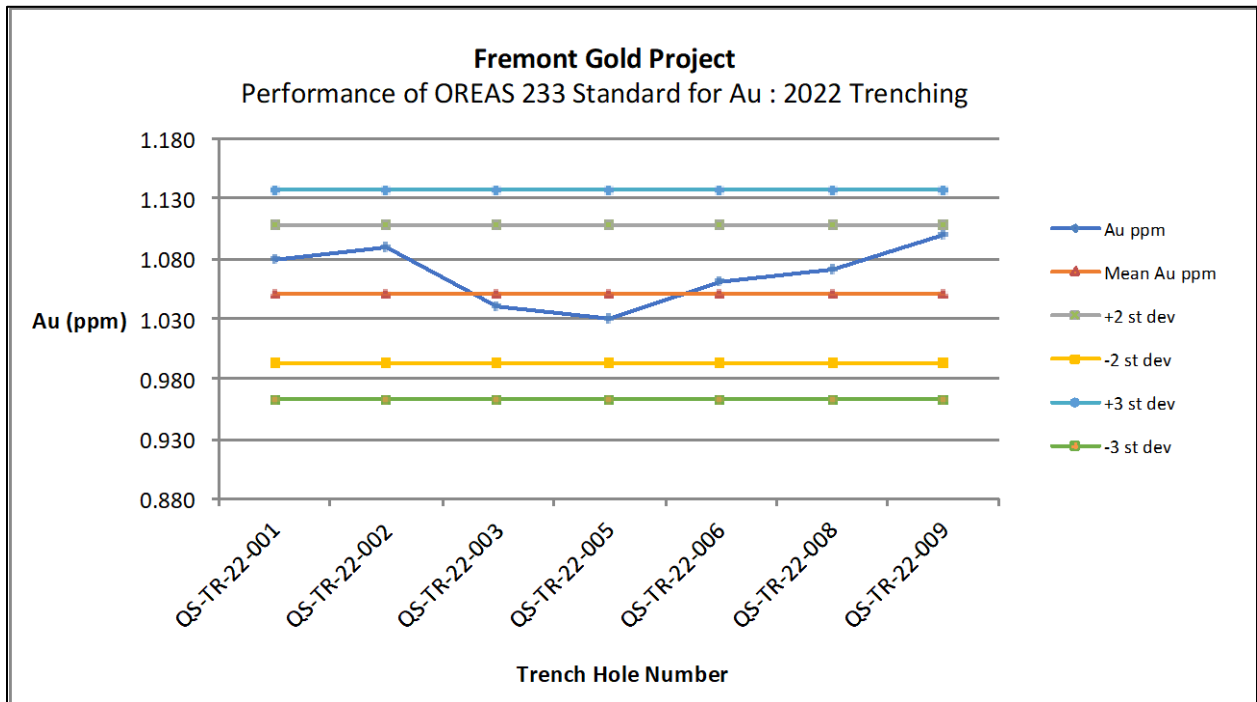
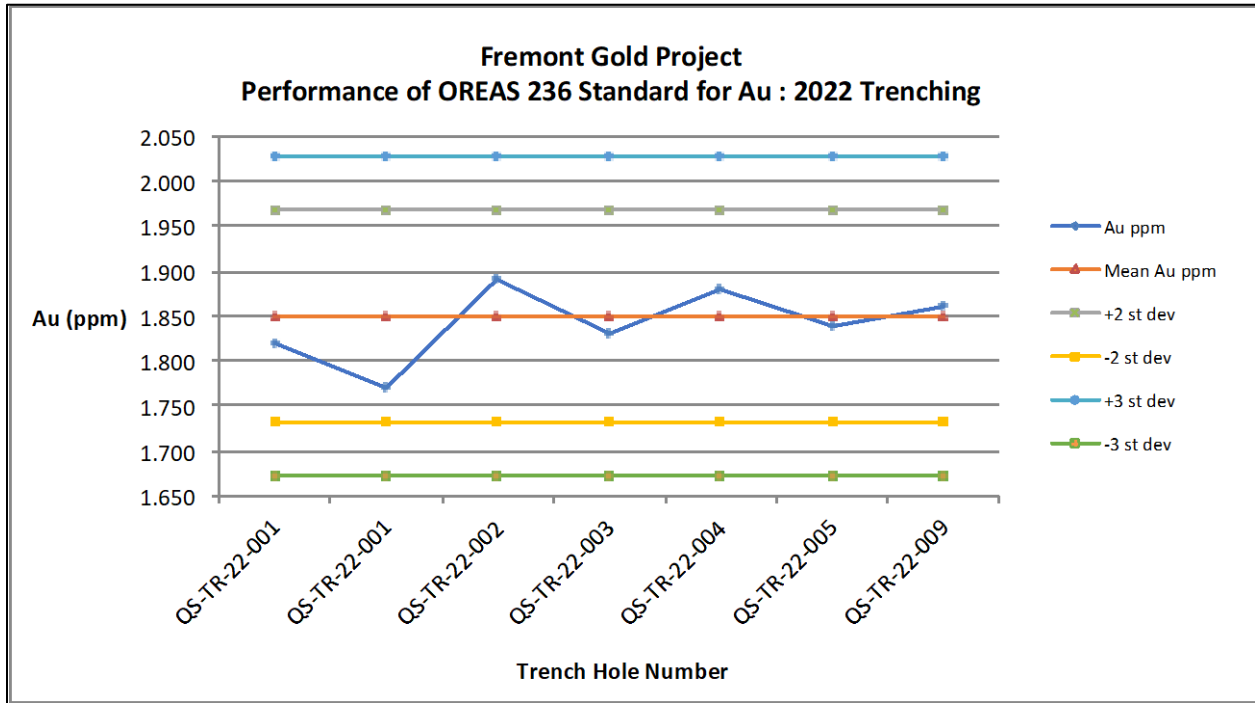

FIGURE 11.11 PERFORMANCE OF OREAS 236 CRM FOR AU



11.5.1.2 Performance of Blank Material

A total of 25 blank samples were submitted for the 2022 trench sampling program at the Project, at a frequency of 5%. All blank data for Au were reviewed by the Author. If the assayed value in the certificate was indicated as being less than detection limit, the value was assigned the value of one-half the detection limit for data treatment purposes. An upper tolerance limit of ten times the detection limit was set.

The vast majority of data plots at or below the set tolerance limits for gold (Figure 11.12), and the Author does not consider the few outliers to be significant to the integrity of the data.

The Author does not consider contamination to be an issue for the 2022 Au trench data.

FIGURE 11.12 PERFORMANCE OF BLANK FOR AU

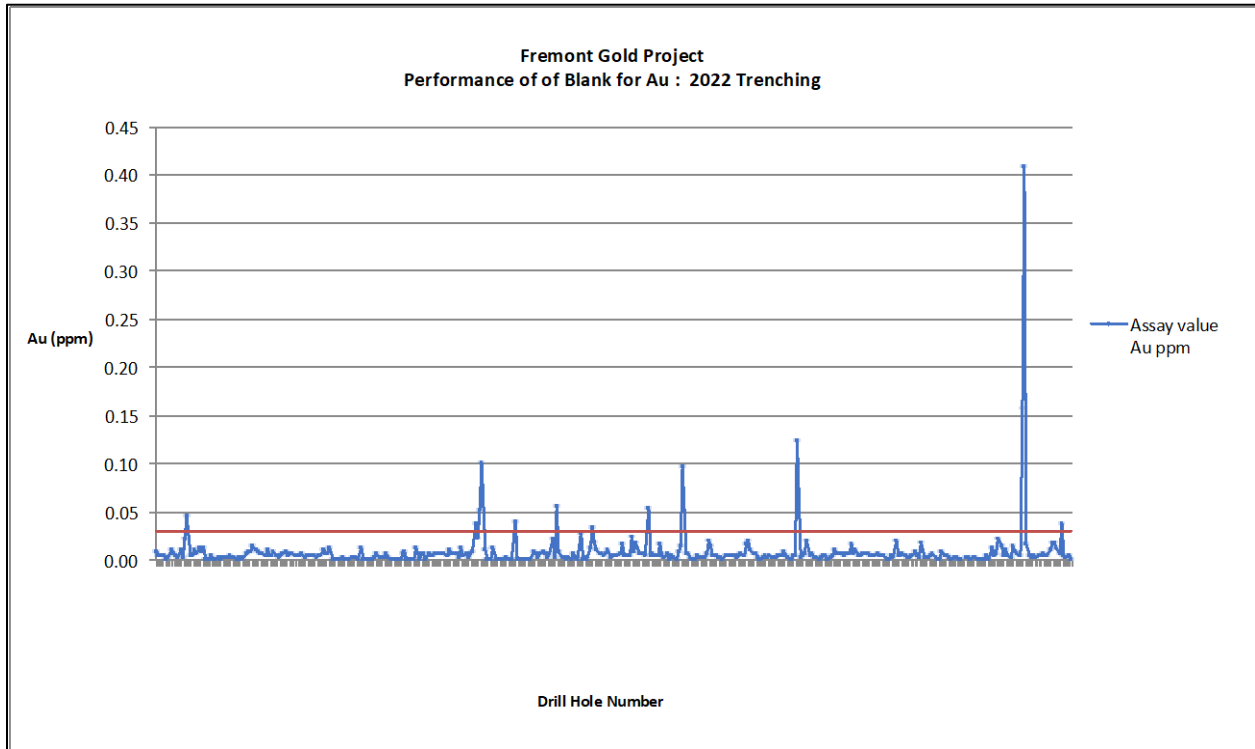

11.5.1.3 Performance of Duplicates

Field duplicate samples were inserted into the sample sequence at a frequency of 5%. There were 17 field duplicate pairs for gold in the data set to review. The Author also examined the lab duplicate pairs, of which there were 50 pairs. The data were scatter graphed and the R^2 and CV_{AV} values were determined for both data sets to evaluate precision.

Field duplicate precision was poor, as expected for sampling and mineralization styles, with data broadly scattered (Figure 11.13), an R^2 value of 0.291, and a CV_{AV} value of 89.7. Precision at the pulp level improves (Figure 11.14), with more tightly constrained data plotting along the 1:1 line, an R^2 value of 0.992, and a CV_{AV} value of 10.4. The Author considers the precision to be acceptable for this style of mineralization.

FIGURE 11.13 PERFORMANCE OF FIELD DUPLICATES FOR AU R² VALUES

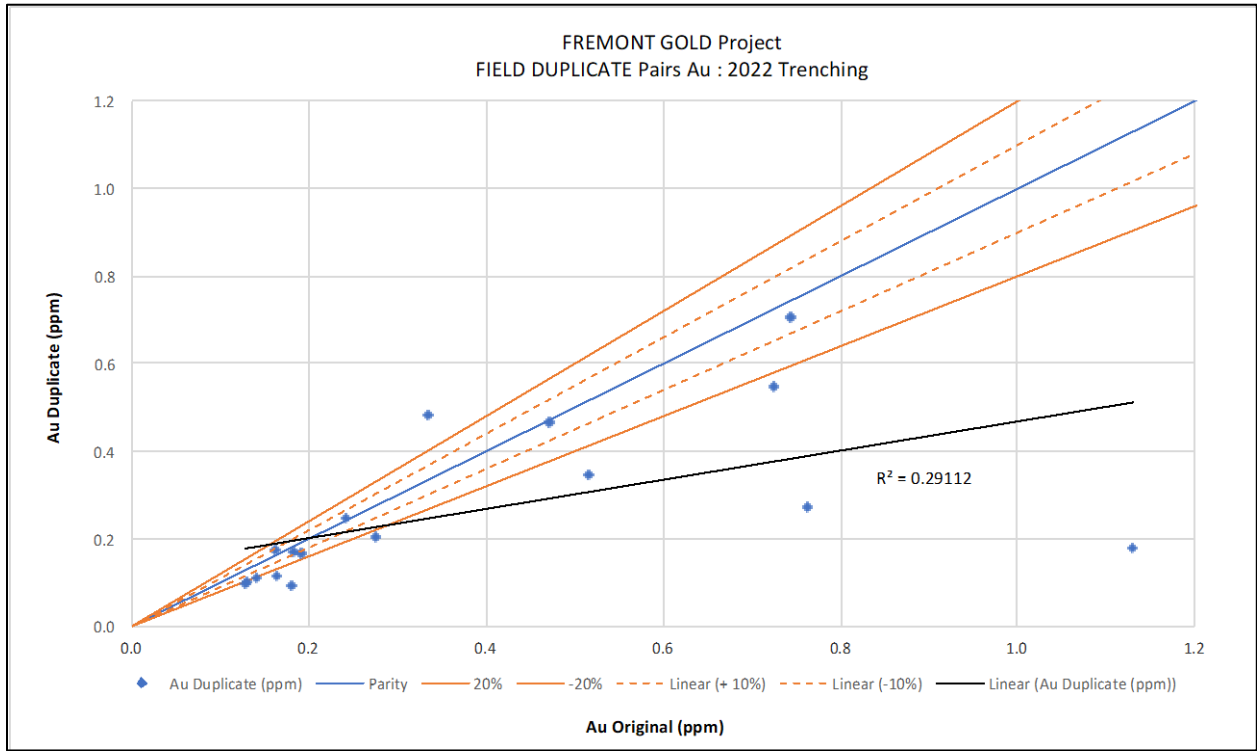
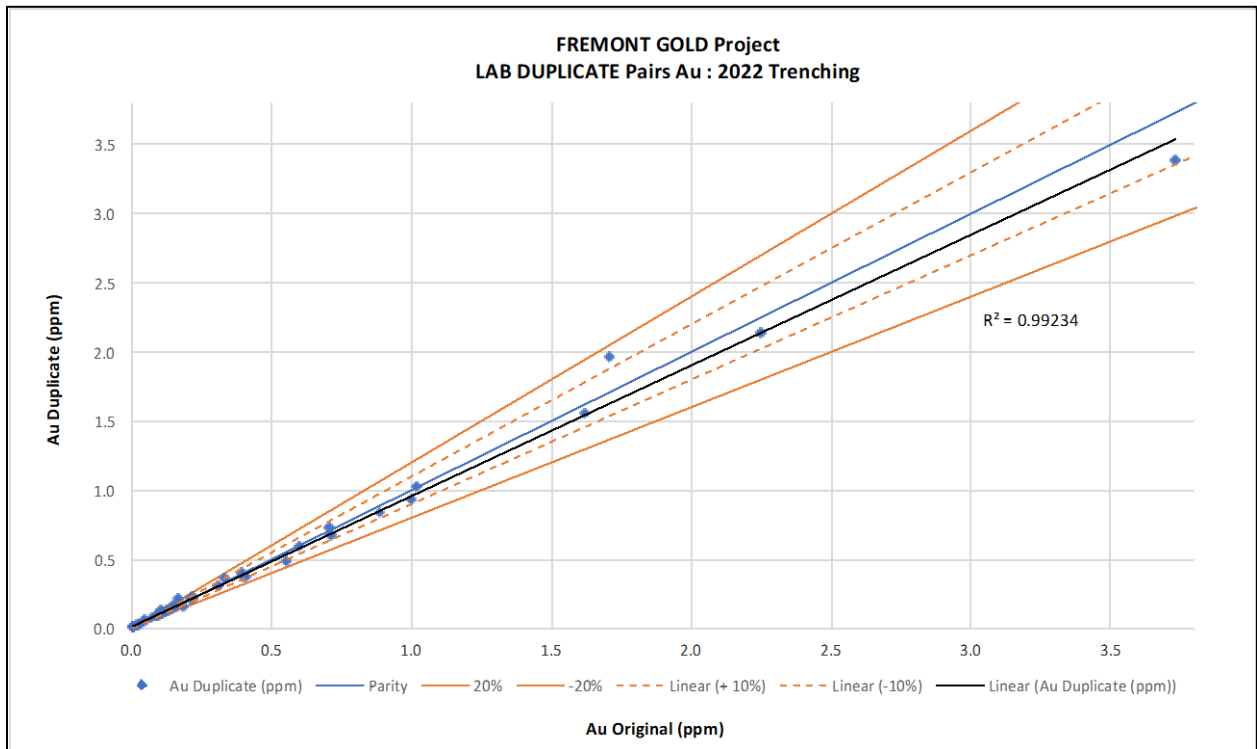

FIGURE 11.14 PERFORMANCE OF LAB DUPLICATES FOR AU



11.6 CALIFORNIA GOLD UMPIRE ASSAYING

Upon completion of the 2016 drill program, California Gold completed a comprehensive umpire-sampling program to confirm the integrity of the analytical results from the 2013 to 2016 drilling campaigns. Select pulverized pulp samples were submitted for check assaying at a secondary umpire laboratory (ALS in Sparks, Nevada), to check original analyses performed at the primary laboratory (AAL). A total of 710 pulp rejects (including nine blanks and 35 CRMs) from 15 holes drilled during the 2013 to 2016 programs, were sent to ALS for check assaying. Samples at ALS were analyzed utilizing the same method as used in the original analyses. The check assays represent 7% of the total assays sampled throughout the 2013 to 2016 period and the samples cover a range of gold values from across the Pine Tree-Josephine Deposit.

The Author reviewed the umpire assay results and comparisons were made between the primary lab results and the umpire lab results with the aid of a scatter plot (Figures 11.15). As expected, lower grades are less reproduceable closer to lower detection limits. However, the original samples and check assays generally compare well, giving an R^2 value of 0.964. A slight bias is evident in the reported primary lab results.

ALS has developed and implemented strategically designed processes and a global quality management system at each of its locations. The global quality program includes internal and external inter-laboratory test programs and regularly scheduled internal audits that meet all requirements of ISO/IEC 17025:2017 and ISO 9001:2015. All ALS geochemical hub laboratories are accredited to ISO/IEC 17025:2017 for specific analytical procedures.

FIGURE 11.15 PERFORMANCE OF LAB DUPLICATES FOR AU 2013-2016

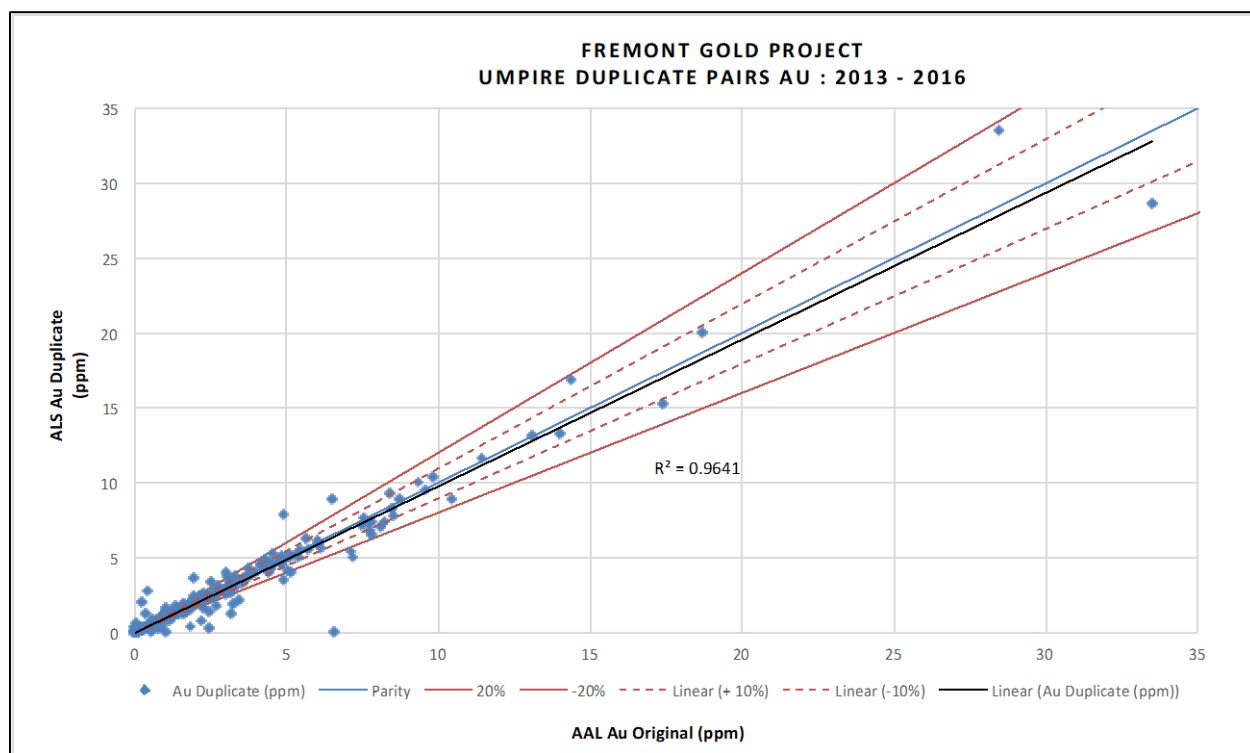

11.7 CONCLUSION

It is the opinion of the Author that sample preparation, security and analytical procedures for the Fremont Gold Project drilling and trench sampling programs were adequate. Examination of QA/QC results for all recent sampling indicates no significant issues with accuracy, contamination or precision in the data and umpire sampling has confirmed the tenor of the original 2013 to 2016 data. The Author concludes the data to be of good quality and satisfactory for use in the current Mineral Resource Estimate.

12.0 DATA VERIFICATION

12.1 DRILL HOLE AND TRENCH ASSAY VERIFICATION

Verification of the 2013-2022 Fremont Gold Project drill hole and trench assay data for gold was performed by the Authors, by comparison of the database entries with assay certificates, provided directly to the Author by AAL of Sparks, Nevada, in .xls and .pdf file formats. Historical RC drill hole data from 1985 and 1986 were verified using .pdf copies of signed Bondar-Clegg Certificates of Analysis, provided to the Authors by Stratabound.

Approximately 77% (9,927 out of 12,861 samples) of the historical 1985-1986 drill hole data, 99% (11,311 out of 11,380 samples) of the 2013 to 2016 drill hole assay data, 90% (2,932 out of 3,274 samples) of the 2017 to 2018 drill hole assay data and 100% (334 samples in total) of the 2022 trench data, were verified for gold, giving an approximate overall figure of 88% of the Project database verified. A few minor discrepancies of no material impact to the data were encountered during the verification process.

12.2 DRILL HOLE AND TRENCH DATA VERIFICATION

The Authors also validated the Mineral Resource database by checking for inconsistencies in analytical units, duplicate entries, interval, length or distance values less than or equal to zero, blank or zero-value assay results, out-of-sequence intervals, intervals or distances greater than the reported drill hole length, inappropriate collar locations, survey and missing interval and coordinate fields. A few errors were identified and corrected in the database. The Authors consider that the supplied database is suitable for Mineral Resource estimation.

Underground channel assay data were compiled by California Gold from historical records. Historical sample data were recorded using only two significant digits for the original ounce/short ton and converted to g/t. The Authors reviewed copies of the historical underground plans and confirmed that the supplied locations and assay grades are in agreement with the historical plans supplied by Stratabound.

12.3 2022 P&E SITE VISIT AND INDEPENDENT SAMPLING

The Fremont Gold Project was visited by Mr. Fred Brown, P.Geo., of P&E, from March 24 to 25, 2022, for the purpose of completing a site visit that included drilling site and outcrop visits, GPS location verifications, discussions and due diligence sampling.

Mr. Brown collected 16 samples from 16 diamond drill holes. All samples were selected from holes drilled in 2015, 2017 and 2018. A range of high, medium and low-grade samples were selected from the stored drill core. Samples were collected by taking a quarter drill core, with the other quarter core remaining in the drill core box. Individual samples were placed in plastic bags with a uniquely numbered tag, after which all samples were collectively placed in a larger bag. Mr. Brown couriered the samples to Mr. David Burga, P.Geo., also of P&E, who then delivered the samples directly to the Actlabs laboratory in Ancaster, Ontario for analysis. At no time prior

to sampling were any employees or officers of Stratabound informed of the location of the samples to be chosen.

Samples at Actlabs were analyzed for gold by fire assay with an Instrumental Neutron Activation Analysis (“INAA”) finish. Bulk density determinations were also taken on all of the samples. The Actlabs’ Quality System is accredited to international quality standards through ISO/IEC 17025:2017 and ISO 9001:2015. The accreditation program includes ongoing audits, which verify the QA system and all applicable registered test methods. Actlabs is also accredited by Health Canada.

A comparison of the Authors’ independent sample verification results versus the original assay results is shown in Figure 12.1.

FIGURE 12.1 AUTHORS SITE VISIT RESULTS FOR AU

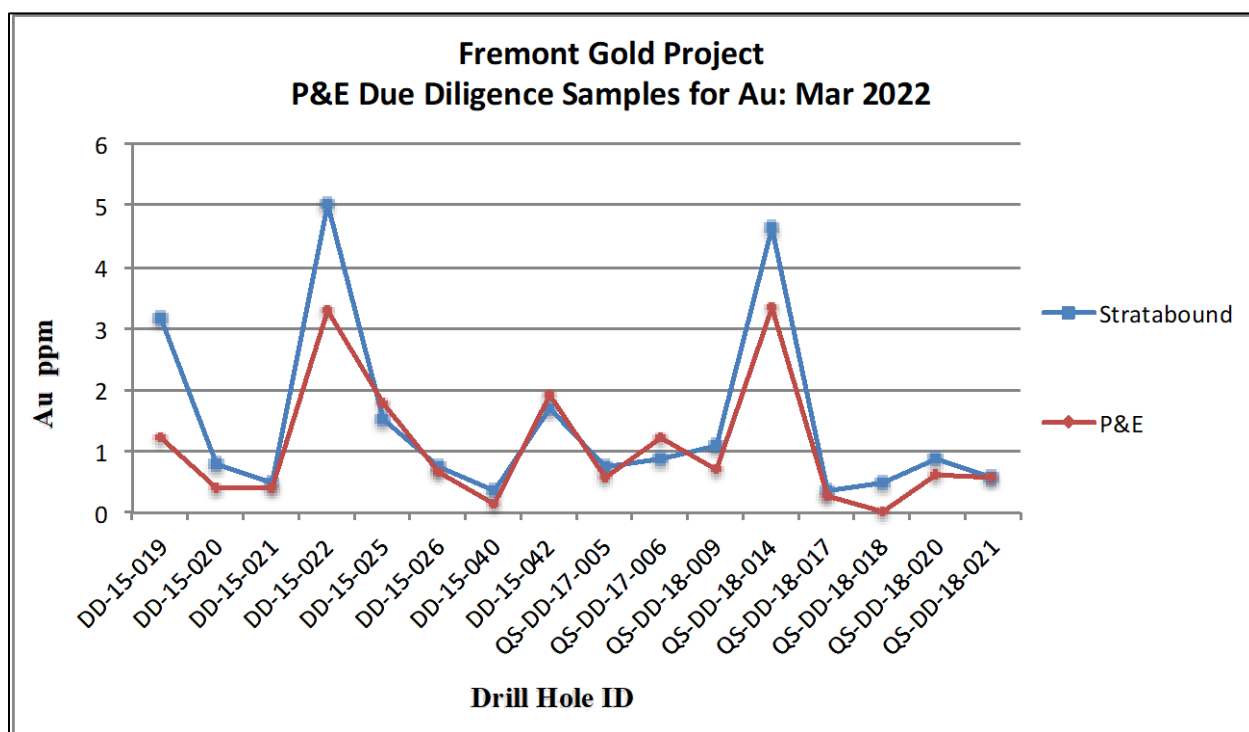

12.4 CALIFORNIA GOLD 2013 DRILL HOLE TWINNING PROGRAM

The first 14 holes of the 2013 drill hole program undertaken at the Property by California Gold were designed to twin a number of Goldenbell’s historical RC drill holes completed at the Pine Tree-Josephine Deposit. Historical holes located across the Pine Tree-Josephine Deposit were selected for twinning and are listed in Table 12.1. Three of the paired drill holes are located within 3.0 m of each other. The Authors have reviewed data relating to the twinned holes and considers the data to generally confirm gold grades and intercept thickness of representative historical RC drill holes. However, a tendency for RC assay samples to be less than the reported diamond drill hole grade for the same elevation was observed.

TABLE 12.1
2013 CALIFORNIA GOLD TWIN HOLES

RC Hole	Diamond Drill Hole	Section
RC-85-070	DD-13-001 & DD-14-018 ¹	19900N
RC-85-029	DD-13-002	20200N
RC-85-067	DD-13-003	20400N
RC-85-065	DD-14-017 ¹	20500N
RC-85-057	DD-13-004	20600N
RC-85-041	DD-13-005	20800N
RC-85-092	DD-13-006	21400N
RC-85-078	DD-13-007	21400N
RC-85-002	DD-13-008	21900N
RC-85-021	DD-13-009	22000N
RC-85-005	DD-13-010	22000N
RC-85-127	DD-13-011	21700N
RC-85-008	DD-13-012	21500N
RC-85-048	DD-13-013	21600N
RC-85-043	DD-13-014 & DD-14-016 ¹	20100N

Note:

1. 2014 holes were drilled for the 2014 metallurgical study.

Source: SLR (2021)

12.5 CONCLUSION

The Authors consider that there is good correlation of the gold assay values in Stratabound's database to the independent verification samples from the site visit and analyzed at Actlabs. It is the Authors' opinion that the data have been suitably verified, and are of good quality and appropriate for use in the current Mineral Resource Estimate.

13.0 MINERAL PROCESSING AND METALLURGICAL TESTING

13.1 PREVIOUS OPERATIONS

Historically, the Pine Tree-Josephine Deposit was treated by a combination of gravity concentration and flotation to concentrate the precious metal values into a pyritic concentrate which was subsequently smelted elsewhere. Since the gold grade decreased in the latter years of mine operation (1935-1944), the flotation concentrate gained more importance. Approximately 45% of the gold was recovered in a pyrite flotation concentrate grading 5.0 oz/t (171 g/t) gold, with an equal amount recovered by gravity methods. The production results, taken from annual reports by the Pacific Mining Company, are presented in Table 13.1.

**TABLE 13.1
HISTORICAL PRODUCTION SUMMARY**

Year	Tons	Grade (oz/t)	Total Au (oz)	Concentrate			Bullion (oz)	Au Recovery (%)	Process
				Tons (T)	Au (oz/t)	Au (oz)			
1933	18,840	0.211	3,975.3			3,111.6		78.3%	Flotation
1935	33,296	0.225	7,491.6	339.7	19.29	6,551.8		86.7%	Flotation
1936	38,756	0.194	7,518.7	677.4	9.28	6,286.6	306.4	87.7%	Flot./Gravity
1937	51,646	0.152	7,850.2	1,394.5	4.43	6,177.5	693.2	87.7%	Flot./Gravity
1938	55,021	0.157	8,638.3	1,374.5	5.07	6,968.9	717.5	89.2%	Flot./Gravity
1939	53,176	0.163	8,667.7	958.2	6.88	6,592.1	1,180.3	89.7%	Flot./Gravity
1940	59,249	0.172	10,190.8	1,384.7	5.48	7,588.0	1,395.3	88.4%	Flot./Gravity

Note: Flot. = flotation.

13.2 TEST WORK PROGRAM

A testing program on the Pine Tree Deposit commenced in early 1986 and continued through to January 1988. The reports numbered 1 to 8 were utilized by Wright Engineers in the preparation of the November 1986 Feasibility Study. Reports numbered 1 to 17 were utilized in the preparation of Wright Engineers "Basic Design Report" dated February 1988. Reports 18 through 23 were utilized in the preparation of Beacon Hill Consultant's "Project Development Report," dated April of 1991. In 2014, Fremont Gold Mining LLC engaged Inspectorate Exploration and Mining Services to complete metallurgical testing on new samples.

All of the test work prior to 2014 segregated the Deposit into zones. These zones included some overlap with lithology and were defined as follows in Table 13.2.

TABLE 13.2	
PRE-2014 MINERALIZED ZONES FOR METALLURGICAL TEST WORK	
Zone	Description
Zone 4	Diorite
Zone 5	Pine Tree
Zone 6	Josephine Ankerite
Zone 7	Josephine Slate

In 2014, new samples were collected and sent to Inspectorate Exploration & Mining Services Ltd. (“Inspectorate”) for evaluation. The new samples were collected, based on different lithological divisions than the previous work, and therefore making direct comparisons difficult between the earlier “Zones” and the samples tested in 2014. The new samples were separated as oxide cap mineralization (“OCM”), sulphide replacement mineralization (“SRM”), and quartz-hosted gold mineralization (“QTZ”).

A list of the historical metallurgical test reports is presented in Table 13.3.

TABLE 13.3			
METALLURGICAL TEST REPORTS			
Report		Date	Company
1	Preliminary Metallurgical Investigation	Feb-86	Bacon, Donaldson & Associates, LTD
2	Metallurgy Study of Goldenbell Ore	May-86	Utah International Inc.
3	Production of Gold Bearing Pyrite Flotation Concentrate from Goldenbell Ore	Jul-86	Utah International Inc.
4	Results of Metallurgical Test work on Pine Tree Concentrate: Gold Recovery	Sep-86	Bacon, Donaldson & Associates, LTD
5	Metallurgical Testing of Pine Tree Project Ore Samples	Sep-86	Bacon, Donaldson & Associates, LTD
6	An Investigation of the Recovery of Gold and Silver from a Pine Tree Flotation Concentrate Sample	Oct-86	Lakefield Research
7	Golden Flotation Pilot Plant	Oct-86	Witteck Development Inc.
8	Roasting/Leaching of Goldenbell Gold/Silver Concentrate	Dec-86	Hazen Research
9	Pine Tree Ore and Tailings Samples for Effluent Characterization	Jan-87	Bacon, Donaldson & Associates, LTD
10	Metallurgical Study of Pine Tree Project Ore Samples	May-87	Bacon, Donaldson & Associates, LTD
11	Pine Tree Gold Pilot Plant, Final Report on Flotation	Jul-87	M.A. Hanna Company
12	Pine Tree Gold Pilot - Final Report on Grinding	Jun-87	M.A. Hanna Company

**TABLE 13.3
METALLURGICAL TEST REPORTS**

	Report	Date	Company
13	Concentrate Dewatering (letter report)	Aug-87	Eimco Process Equipment Company
14	Dead Roasting and Two Stage Roasting of Gold Ore Test Report	Nov-87	Lurgi Plant in Frankfurt, Germany
15	Thickening of Goldenbell Roaster Calcine	Dec-87	Bacon, Donaldson & Associates, LTD
16	Pine Tree Project Review of Grinding Mill Sizing		
17	Carbon-in-Leach processing of Goldenbell Roaster Calcine	Feb-88	Bacon, Donaldson & Associates, LTD
18	Cyanidation of Goldenbell Calcines	Mar-88	Bacon, Donaldson & Associates, LTD
19	Supplementary Flotation and Gold Recovery Sulfides	Oct-88	Bacon, Donaldson & Associates, LTD
20	Preliminary Evaluation of Bioleaching on Precious Metal Recovery from Pine Tree Concentrate	Jul-86	Giant Bay Biotech Inc.
21	Bioleaching of Pine Tree Concentrate	Jun-89	Giant Bay Biotech Inc.
22	Bottle Roll and Column Cyanidation Tests of Pine Tree Oxide	Aug-88	Bacon, Donaldson & Associates, LTD
23	Pine Tree Project Grinding Evaluation	Feb-88	J.H. Bassarear
24	Metallurgical Testing of Samples from the Fremont Project, California	Aug-14	Inspectorate Exploration & Mining Services

Sections 13.3 and 13.4 were based on, with formatting and text modifications, the Beacon Hill Consultants Ltd. "Project Development Report," dated April 1991 (Beacon Hill, 1991).

13.3 SCOPING TEST WORK

In early 1986, a test program was initiated at Bacon Donaldson and Associates on Pine Tree mineralized material to obtain preliminary environmental and metallurgical information. The results are presented in Report No. 1. Generally, the results were as follows:

1. Gravity concentration produced a concentrate of fine gold and coarse pyrite, with recoveries being as follows in Table 13.4.

Area	Concentrate Au (oz/t)	Au Recovery (%)
Zone 4	0.155	8.1
Zone 5	3.332	31.5
Zone 6	1.443	20.8

The gold grains in the concentrates were all <200 µm in size:

2. Cyanidation of a composite mineralized material sample yielded gold extractions of 42.2 and 82.4% at minus 3/8 inch and 50% minus 200 mesh, respectively;
3. Cyanidation of composites 4, 5 and 6 yielded gold extractions of 87.5%, 11.1% and 0.0%, respectively, at grinds of approximately 50% minus 200 mesh. The Zone 6 mineralized material utilized for this work was subsequently reclassified into two zones; Josephine Ankerite (Zone 6) and Josephine Slate (Zone 7);
4. Flotation of the overall composite yielded gold recoveries of 86.2 to 93.8%, with concentrate grades of 1.047 to 1.381 oz/t (36 g/t to 47 g/t);
5. Cyanidation of this concentrate yielded 34% gold extraction without regrinding, 35.4% after being reground to minus 200 mesh, and 47.1% after a regrind to 84% minus 400 mesh; and
6. Thioureaation of reground concentrate yielded a maximum of 64% gold extraction.

The conclusions of this report were that the gold in the flotation concentrate was 'refractory' in nature and that test work involving more severe treatment (pressure oxidation, Arseno process, bio leaching) should be carried out (Bacon, Donaldson and Associates, 1986).

Test work was next carried out in the laboratory of Utah International in March and April, 1986. Their initial investigations examined direct cyanidation of the mineralized material, flotation followed by cyanidation, and finally pre-treatment of flotation concentrate to increase cyanidation recovery.

The complete results were provided in their report "Metallurgical Study of Goldenbell Ore", May 1986, and are summarized below in Table 13.5.

TABLE 13.5				
MAY 1986 METALLURGICAL TEST WORK RESULTS				
Test Work Stage	Mineralized Material Type			
	Zone 4	Zone 5	Zone 6	Zone 7
Direct Cyanidation, Gold Extraction (%)	90	60	25	5
Flotation Recovery (%)	90	80	85	90
Conc. Grade Au (oz/t)	0.5	1.5-2.3	1.5-2.3	1.2-2.0
Cyanidation of Concentrate, Gold Extraction (%)	100	95	75	35
Pre-treatment and Cyanidation Gold Extraction in (%):				
Hypochlorite				65
Autoclave Oxidation				70
Roasting with Lime				92

A number of other pre-treatment methods, such as aeration with lime, hot caustic, lead nitrate addition and a carbon-in-leach, were unsuccessful.

The refractory nature of the Zone 7 and Zone 6 concentrates was identified as being caused by carbonaceous material that adsorbs (preg-roads) the gold from cyanide solution. Tentatively the “preg robbing” mineral was identified as graphite. Based on these initial results, a recommendation to use autoclave oxidation on flotation concentrates was made.

As a follow-up to the previous work, Utah International subsequently ran a pilot plant campaign to produce significant quantities of flotation concentrate from Zones 6 and 7 mineralized material for further test work. The pilot plant results are listed in Table 13.6.

TABLE 13.6		
UTAH INTERNATIONAL PILOT PLANT FLOTATION CONCENTRATE		
Area	Flotation Gold Recovery (%)	Concentrate Gold Grade (oz/t)
Zone 6	85	1.49
Zone 7	88	1.22

Sufficient concentrate was produced for further tests on oxidation at various laboratories in the next phase of testing. A secondary test at Utah International on floating carbonaceous material away from the pyrite concentrate was unsuccessful. Results were reported in “Production of Gold Bearing Pyrite Flotation Concentrate from Goldenbell Ore” (July 1986 - Appendices).

The Zone 7 concentrate produced in the Utah International pilot plant was shipped to Bacon Donaldson & Associates for further test work. The concentrate sample was subdivided into a

number of samples for testing at various laboratories and by proprietary processes. The laboratories and processes utilized are listed in Table 13.7.

Laboratory	Process
1. Bacon Donaldson & Assoc.	1.1 Direct cyanidation
	1.2 Oxygen pressure leach
	1.3 Arseno Process
	1.4 Roasting
2. Giant Bay Resources	2.1 Bioleach
3. Calmet	3.1 Calmet
4. Lakefield Research	4.1 Roasting
	4.2 Pressure oxidation
5. SKW Trostberg	5.1 Pressure thioureaation

The test work on the Utah International concentrate shipped to Bacon, Donaldson and Associates, and then distributed to various laboratories was complicated by the fact that the Zone 7 concentrate received was lower grade than expected. The Utah International pilot plant reported grades in excess of 1 oz/t Au and approximately 18% S. The concentrate actually received was only 0.745 oz/t (25.5 g/t) Au and 12.8% S (Bacon, Donaldson and Associates assay). Both Bacon, Donaldson & Associates and Lakefield Research refloated the concentrate and upgraded it to over 1 oz/t (34.3 g/t) Au and approximately 20% S for testing. The results of the test work by all the laboratories are summarized in Table 13.8.

TABLE 13.8
SUMMARY OF PRECIOUS METAL EXTRACTION IN PERCENT

Group	Concentrate	Direct Cyanidation		Oxygen Pressure Leach		Roasting		Bioleach		Calmet		Pressure Thioureaation		Arseno Process		Hypochlorite	
		Au	Ag	Au	Ag	Au	Ag	Au	Ag	Au	Ag	Au	Ag	Au	Ag	Au	Ag
Bacon, Donaldson & Assoc.	1*	49.5		61.5										74.5		74.1	73.4
Bacon, Donaldson & Assoc.	2**			72.3	75.3	90.3	50.2							80.9	90.5		
Lakefield Research	2			58	34	87	47										
Giant Bay	1							84.5	51.6								
SKW Trostberg	1											60					
Calmet	1	2								30							

Notes:

* 1 Utah Concentrate.

** 2 Refloated Concentrate.

As indicated by the results presented in Table 13.8, the three most effective treatments are listed in Table 13.9.

TABLE 13.9		
MOST EFFECTIVE METALLURGICAL TREATMENTS		
Treatment Type	Au Extraction (%)	Ag Extraction (%)
1. Roasting	90.3	50.2
2. Bioleach	84.5	51.6
3. Arseno Process	80.9	90.5

13.4 HISTORICAL TEST WORK DETAILS

13.4.1 Samples

The work described in Reports 1 to 8 was carried out on reverse circulation drill cuttings, with the exception of the lock-cycle flotation tests (Report No. 5), which were done on split diamond drill core. The test work described in Reports 10 to 15 was carried out on composite samples obtained from an underground bulk sampling program to provide confirmatory data for final design. With the exception of the work described in Reports 15 and 17, all testing of bulk samples was requested by NorthWest Gold Corp. and carried out under their direction by the various laboratories. The roasting test work was commissioned by NorthWest Gold Corp. and witnessed by Wright Engineers Limited and Minproc Inc.

13.4.2 Grinding

The early flotation test work indicated that a primary grind of approximately 50% minus 200 mesh was required for good rougher gold recovery. A series of Bond work index tests was run at Bacon, Donaldson and Associates to determine the work indices of the various Zones. The results are listed in Table 13.10.

TABLE 13.10	
BACON, DONALDSON AND ASSOCIATES BOND INDEX TEST RESULTS	
Zone	Bond Wi @ 50 mesh (kWh/ton)
Zone 5	11.3
Zone 6	11.1
Zone 7	10.6

Wright utilized the above data for preliminary sizing of a SAG mill and ball mill for the feasibility study. In early 1987, semi-autogenous grinding tests were conducted on a 60-ton representative

bulk sample of Pine Tree mineralized material at the Hanna Research Centre. Detailed results of the tests are listed in Report No. 12.

The report concluded that the mineralized material was amenable to semi-autogenous grinding and was a relatively "soft-grinding" mineralized material.

In order to meet a final grind size of 80% minus 100 mesh (150 µm), the mineralized material required a total of 6 kWh/ton, split evenly between the primary and secondary mills. For a process plant design throughput of 360 tons/h (325 t/h), 2,000 hp (1.49 MW) grinding mills were recommended by Hanna.

One test of single-stage, semi-autogenous grinding indicated that the mineralized material could be ground to 80% -100 mesh in a single stage. Estimated power requirements were 6 to 7 kWh/ton (5 to 6 kWh/t).

Based on the Hanna test results, Wright sized and selected the following mills for the Pine Tree Project:

Primary Mill: 22 ft dia x 8.5 ft
2,250 hp (1.68 MW) semi-autogenous mill.

Secondary Ball Mill: 13.5 ft dia x 20 ft
2,250 hp (1.68 MW) ball mill.

An independent internal review of the grinding test program was completed, which confirmed the validity of the test results and the grinding mill sizing. (See Report No. 16 – “Pine Tree Project Review of Grinding Mill Sizing”). A further review was conducted by J. Bassarear, an independent consultant (Report No. 23). Bassarear worked with an incomplete set of data and was in general agreement with the grinding mill sizing.

13.4.3 Flotation and Concentrate Dewatering

The results are presented below in chronological order for the various testing facilities.

January/February 1986

Preliminary Investigation, Bacon Donaldson and Associates (Report No. 1).

Type: Overall composite (i.e., Zone 4, 5, 6) where Zone 6 was later divided into Zones 6 and 7.

Grind: 56% minus 200 mesh.

Results: see Table 13.11.

TABLE 13.11			
BACON, DONALDSON AND ASSOCIATE JANUARY / FEBRUARY 1986 TEST WORK RESULTS			
Concentrate		Recovery	
Au (oz/t)	Ag (oz/t)	Au (%)	Ag (%)
1.0	0.3	92	80

May 1986

Metallurgical Study of Goldenbell Ore, Utah International (Report No. 2). Test work results are shown in Table 13.12.

TABLE 13.12				
UTAH INTERNATIONAL MAY 1986 TEST WORK RESULTS				
Results	Mineralized Material Zone			
	Zone 4	Zone 5	Zone 6	Zone 7
Gold Recovery (%)	90	80	85	90
Gold Concentrate Grade (oz/t)	0.5	1.5-2.3	1.5-2.3	1.2-2.0

Primary Grind: 15-25% plus 100 mesh.
50-55% minus 200 mesh.

Concentrate Re grind: 80% minus 400 mesh.

July 1986

Flotation Pilot Plant, Utah International (Report No. 3).

Types Tested: Zone 6 and Zone 7. Results shown in Table 13.13.

TABLE 13.13		
UTAH INTERNATIONAL JULY 1986 METALLURGICAL TEST WORK RESULTS		
Results	Zone 6	Zone 7
Avg. Gold Recovery (%)	85	88
Sulphur Recovery (%)	88	75
Gold Concentrate Grade (oz/t)	1.49	1.22
Sulphur (%)	24	18.2

Grind: Primary; 10-12% plus 100 mesh, 60% minus 200 mesh.
 Regrind; 90% minus 400 mesh.

Flotation Time: Rougher/Scavenger: 20 min.
 1st Cleaner: 13 min.
 2nd Cleaner: 12 min.

August 1986

Locked Cycle Flotation Testing, Bacon, Donaldson and Associates (Report No. 5). The test work results are shown in Table 13.14.

TABLE 13.14					
BACON, DONALDSON AND ASSOCIATES AUGUST 1986 TEST WORK RESULTS					
Results		Composite	Zone 5	Zone 6	Zone 7
Au Recovery (%)	Rougher	91.7	91.3	91.6	93.6
	Cleaner	91.3	84.0	89.1	90.1
Au Concentrate Grade (oz/t)		1.360	2.845	1.416	1.396

Grind: Primary; 33-48% minus 200 mesh.

September 1986

Pilot Plant Flotation, Witteck Development (Report No. 7). The test work results are shown in Table 13.15.

TABLE 13.15				
WITTECK DEVELOPMENT SEPTEMBER 1986 TEST WORK RESULTS				
Results	Zone 5	Zone 6	Zone 7	Zone 5, 6, 7 Composite
Avg. Au Recovery (%)	77.8	78.7	90.9	70.9
Concentrate Grade:				
Au (oz/t)	0.75-1.10	0.33-1.77	0.56-0.84	1.46
S (%)	9.0-12.5	6.3-20.4	11.3-15.3	24.9

Grind: 20% plus 100 mesh, 55% minus 200 mesh.
 Regrind: 82% minus 400 mesh.

These results from Witteck are averages based on daily composite samples, and thus reflect circuit upsets and equipment problems. The concentrate for the composite sample was purposely maintained at a high sulphur level, thus causing some recovery loss.

June/July 1987

Two complementary series of flotation tests were conducted on the composite underground bulk sample. The first tests (Report No. 10) were a series of locked cycle tests carried out by Bacon, Donaldson and Associates. These tests indicated that a flotation circuit consisting of a rougher-scavenger followed by two stages of closed-circuit cleaning would yield satisfactory flotation recoveries. At an initial grind of 80% -100 mesh, there was no advantage to a cleaner concentrate or cleaner tail regrind.

The report concluded that a composite sample would yield an overall gold recovery of 89.7% at a gold grade of 1.48 oz/ton (50.7 g/t) and a sulphur grade of 20.8%. Depramin was utilized as a slime depressant and overall silver recovery was reported as 71.7%.

A gravity concentration stage recovered 10 to 12% of the gold and such a circuit was recommended for the process plant.

A concentrate thickening unit area of 1.8 ft²/tpd was required. The concentrate filtering rate was found to be 20 lb/hr/ft² at a cake moisture of 20%. The tailings thickener area was reported to be 1.0 to 1.4 ft²/tpd for thickening to 50% solids. High-rate thickening tests were not performed.

The second series of flotation tests was carried out at Hanna Research Centre on the ground material prepared during the pilot plant grinding test. The material was treated in a continuous flotation pilot plant to produce sulphide concentrate for subsequent roaster tests. Test details are given in Report No. 11. The flotation pilot plant utilized the flowsheet developed by Bacon Donaldson & Associates, and also the reagent suite recommended by them.

A comparison of the flotation times used in the pilot plant with those prepared by Bacon, Donaldson & Associates is given Table 13.16.

Material Stage	Retention Time (minutes)	
	Bacon Donaldson	Hanna Pilot Plant
Conditioner	10	33
Rougher	10	38
Scavenger	15	24
1 st Cleaner	15	15
2 nd Cleaner	6	15

It is apparent from the comparative retention times that the Hanna pilot plant equipment was somewhat over-sized. No data were reported to verify flotation rates in the rougher section or the scavenger section, which had extended retention times compared to the laboratory locked cycle tests.

The flotation concentrate produced in the pilot plant was higher-grade, averaging 2.24 oz/ton (76.8 g/t) Au and 32.10% S. At this grade, recovery was only 78.1% compared to the 89.7% obtained in the locked cycle tests.

A review of all metallurgical test results from Utah International, Bacon, Donaldson & Associates, Witteck Development, and Hanna Mines generated a grade recovery curve for the Pine Tree mineralized material that indicated sulphur grades of 12 to 15% would be required for 90% gold recovery. The range of sulphur grades chosen for roaster design was from 10 to 17%.

A separate sample of concentrate was sent to Eimco for filtration test work. The results are reported in Report No. 13. The concentrate filtered readily on a belt-type filter. Disc filters were not suitable, due to fast settling coarse pyrite. There were no thickening tests performed on either concentrate or tailings. Consequently, the locked cycle thickening rates were utilized for concentrate and the Witteck Development pilot plant thickening rates for tailings.

October 1988

Bacon, Donaldson & Associates carried out test work to determine if the carbon in the mineralized material could be separated from the sulphides and gold. This test work included both flotation testing and gravity concentration. In order to evaluate the effectiveness of the carbon removal steps, the resulting sulphide products were cyanided directly or were treated hydrometallurgically prior to cyanidation. Full results are presented in Report No. 19.

It was shown that a significant proportion of the carbonaceous material present in the Pine Tree mineralized material could be removed by flotation prior to sulphide flotation. For Zone 7 material, 5% or less of the gold was associated with the carbon product. For composite material which had an increased free gold content compared to Zone 7, the gold associated with the carbon product was proportionately higher. The possibility for the recovery of gold from the carbon product was not addressed.

The use of gravity concentration using a centrifugal concentrator to eliminate the carbon problem was not successful.

A gold recovery comparable to that achieved by roasting was achieved with the following steps:

- a. Removal of graphite concentrate,
- b. Production of a sulphide concentrate,
- c. Oxidative pre-treatment of the concentrate, and
- d. Cyanidation of the leach residue.

Carbon Flotation

Tests were conducted on Zone 7 mineralized material utilizing fuel oil as the collector. An optimum addition of 0.75 lb/ton (0.36 kg/t) was determined. Results are given in Table 13.17.

Test No.	Float Time (min)	Weight % Floated	Au % Floated
7382-F4	10	6.32	5.63
7382-F1	10	9.74	9.68
7382-F2	10	6.43	5.22

The results shown are for rougher carbon flotation. The concentrates from further tests were cleaned once. In each case, approximately one third of the gold reported to the cleaner tail. The gold loss to the final carbon concentrate varied from 3.77 to 6.30% of the total gold under identical conditions. It was visually estimated that 90% carbon recovery was achieved.

13.4.4 Gravity Concentration

Tests were conducted on a Zone 7 sample and a composite sample to determine whether a gravity concentrate that was low in carbon, and contained most of the gold, could be produced. The tests were performed using a centrifugal concentrator manufactured by Canadian Gold Centrifuge Ltd. It was hoped that the carbon would be rejected, due to its low specific gravity, and the gold and sulphide minerals retained. The results of these tests indicated 15.8 and 30.4% gold recovery for Zone 7 and the composite sample, respectively. The low gold recovery together with the fact that carbon was observed in the concentrate, resulted in a decision to abandon this line of test work.

Some tests were conducted on the use of gravity concentration to remove carbon from rougher flotation concentrate. Bulk sulphide concentrates were prepared by flotation, and subsequently upgraded by means of the centrifugal concentrator. The results, which are summarized in Table 13.18 below, indicated very low gold extraction for cyanidation of the centrifuge concentrates. Further gravity concentration test work was, therefore, abandoned.

Test No.	Zone	Au Recovery %		
		Float	Centrifuge	Cyanide
8033-F3	Comp	90.6	77.2	55.7
8033-F4	7	55.0	93.1	38.0

13.4.5 Treatment of Carbon Removal Products

- a. Cyanidation of carbon flotation tails:

A sample of Zone 7 mineralized material was subjected to carbon flotation. The tailing from this float was cyanided for 24 hours. A gold extraction of 14.8% was

achieved from the tails. It was apparent that the carbon rougher float tails were highly refractory.

b. Cyanidation of sulphide concentrate produced after carbon flotation:

A carbon concentrate was removed prior to sulphide (gold) flotation. The sulphide concentrate was cleaned twice prior to being cyanided. A 24-hour cyanidation extracted 59% of the gold from the concentrate. The results indicated that either sufficient carbon remained in the sulphide concentrate to cause preg robbing or the gold was locked within the sulphides.

c. Cyanidation of the sulphide concentrate following re-oxidation:

The cleaned sulphide concentrate from (b) above was treated by means of the Arseno Process prior to being cyanided. During the Arseno leach, 7.3% of the gold was dissolved. The residue from the pre-treatment was cyanided and yielded a gold extraction of 90.1%. The overall gold extraction from the concentrate was calculates as follows:

Gold to leach solution	=	7.3%
Cyanidation of residue, 90.1% x 92.7%	=	83.5%
Total	=	90.8%

This gold extraction is comparable to that which was achieved by roasting. However, gold recovery to the sulphide concentrate was only 81.6% compared to 90% for the concentrate utilized in the roasting test work.

13.4.6 Roasting and Calcine Leaching

During the scoping stage of test work, Utah International, Bacon, Donaldson & Associates and Lakefield Research conducted small-scale batch roasting tests on Pine Tree concentrates (Reports No. 2, 4, and 6, respectively). In each case, cyanidation of the calcine gave a gold recovery of approximately 90%.

In order to more closely define the roasting parameters, a new series of tests were undertaken, beginning in September 1986. These tests consisted of a flotation pilot plant at Witteck Development Inc. to produce sufficient concentrates for a roasting test program at Hazen Research. The pilot plant run was completed on September 19, 1986, and roasting test work began at Hazen Research in mid-October. The head assay of the composite (Zones 5, 6, 7) concentrate sample received at Hazen Research are presented in Table 13.19.

TABLE 13.19					
WITTECK COMPOSITE CONCENTRATE SAMPLE ASSAY					
Au (oz/t)	Ag (oz/t)	S (%)	CO₂ (%)	Org C (%)	Hg (ppm)
1.09	0.455	17.6	2.16	0.74	1.2

The results of the test work program at Hazen are summarized in Table 13.20 and detailed in Report No 8.

TABLE 13.20							
ROASTING TEST RESULTS – HAZEN RESEARCH							
Roast Conditions		Calcine Assay		Residue Assay		Extraction	
Temp. (°C)	Time (Sec.)	Au (oz/t)	Ag (oz/t)	Au (oz/t)	Ag (oz/t)	Au (%)	Ag (%)
550	5	1.22	0.54	0.538	0.4	55.9	25.9
550	10	1.08	0.51	0.204	0.33	81.1	35.3
550	15	1.04	0.43	0.12	0.31	88.5	27.9
600	5	1.1	0.49	0.148	0.4	86.5	18.4
600	10	1.03	0.43	0.126	0.31	87.8	27.9
600	15	1.16	0.51	0.124	0.36	89.3	29.4
650	5	1.14	0.42	0.148	0.25	87	40.5
650	10	1.14	0.42	0.142	0.2	87.5	52.4
650	15	1.17	0.46	0.118	0.2	89.9	56.5
700	5	1.21	0.44	0.122	0.24	89.9	45.5
700	10	1.22	0.46	0.12	0.32	90.2	30.4
700	15	1.22	0.45	0.118	0.28	90.3	37.8
750	5	1.2	0.42	0.5	0.36	87.5	14.3
750	10	1.2	0.42	0.164	0.4	86.3	4.8
750	15	1.2	0.2	0.166	0.3	86.2	--

The best gold and silver extractions were obtained at temperatures of 650 to 700°C, with a 15 second residence time. Gold extraction was 89.9 to 90.3% and silver extraction was 56.5% at 650°C. Both silver and gold extraction fell off rapidly as the temperature was raised above 700°C. The cyanide leaching conditions for these tests were 10 lb/ton NaCN (based on calcine weight) and 16 hours residence time. A lime pre-aeration was carried out to minimize cyanide consumption, which was approximately 2.6 lb/ton (1.3 kg/t). Lime consumption was 22 lb/ton (11 kg/t). The reagent consumptions for cyanidation of calcine at the various laboratories are summarized in Table 13.21 below. The leach time required was in the order of 16 hours.

TABLE 13.21
CALCINE CYANIDATION REAGENT CONSUMPTION AND RESULTS BY LABORATORY

Type	Laboratory	Lime Consumption	Cyanide Consumption	Au Extraction	Ag Extraction
		(lb/ton)	(lb/ton)	(%)	(%)
Zone 7	Bacon, Donaldson & Associates	N/A	N/A	90.3	50.2
Zone 7	Utah International 550°C	612*	2.52	92.1	53.7
Zone 7	Lakefield 550°C	5.13	4.85	87	47
Composite	Hazen 650°C	22	2.62	90	56.5

* High lime consumption as excess lime was added to roaster feed.

In order to provide design data for the "Basic Design Report", a continuous pilot plant roasting test on Pine Tree concentrate was carried out at the Lurgi Plant in Frankfurt, Germany in October 1987. The results are presented in Report No. 14. The roasting test results indicated that a two-stage, low-temperature, fluid bed roast was the preferred roaster configuration for maximum subsequent gold extraction. The roaster test was carried out on a combined jig/flotation concentrate containing 19.5% sulphur and 1.7% arsenic. The roasted calcines were leached by Bacon, Donaldson & Associates to determine gold recovery, lime and cyanide consumption and leach residence time required (Report No.17 and 18). These results are listed in Table 13.22.

TABLE 13.22
BACON, DONALDSON AND ASSOCIATES CALCINE CYANIDATION RESULTS

Test No.	Roaster Configuration	Roaster Temperature (°C)		Au Extraction
		Stage 1	Stage 2	(%)
1	2-stage	700	650	91.9
2	2-stage	650	600	92.3
3	1-stage	700		72.6
4	1-stage	700		83.0
5	1-stage	650		86.0
6	1-stage	600		91.9
7	1-stage	730		77.1
8	2-stage	600	650	92.6

Based on these cyanidation results, the average gold extraction for 2-stage roasting was 92.27%, and for single stage roasting 82.12%. Two-stage roasting at lower temperatures (600°C, 650°C) was thus indicated as being the best selection.

Further test work was done (Report No. 17) on carbon loading utilizing regenerated carbon from an operating plant. Gold loadings of 200 oz/ton (6,850 g/t) were obtained.

13.4.7 Sulphur Dioxide Absorption Capacity of Flotation Tailings

As part of an investigation to reduce the capital and operating costs for roaster off-gas cleaning, the use of leached roaster calcine and flotation tailings as neutralizing agents was considered. The flotation tailings contain a high proportion of the carbonate mineral ankerite and it was thought that SO₂ could be scrubbed and neutralized using the tailings pulp. Nine tests were conducted at Bacon, Donaldson & Associates in May 1988 to determine the neutralization capacity of both tailings and calcine. The results were communicated to Wright Engineers by FAX. No formal report was produced.

Method

Dry tailings or calcine were added to sulphuric acid and sulphuric/sulphurous acid solutions and agitated for up to four hours at temperatures ranging from ambient to 100°C. Sulphur analyses were conducted on the solutions and solids at regular intervals during each test.

Results

- Reasonable sulphur balances were obtained on 7 of the 9 tests.
- Neutralization took place above 40°C and appeared to be optimum at 60°C.
- 100 g of tailings neutralized 1.07 g of sulphur in a sulphuric acid solution where the acid was added progressively. The test was not taken to its end point.
- 100 g of tailings neutralized 0.76 g of sulphur in a solution containing 17.5 g/L H₂SO₄ in a 6% H₂SO₃ solution.
- 100 g of calcine-neutralized 0.84 g of sulphur in a solution containing 17.5 g/L H₂SO₄ in a 6% H₂SO₃ solution.

It was concluded that flotation tailings and leached calcine could provide the neutralizing capacity required to scrub roaster off-gases and a continuous pilot program was proposed.

13.4.8 Bioleaching

In 1986 Giant Bay Biotech Inc. conducted a batch bioleaching test on Zone 7 concentrate. A recovery of 84.5% was obtained. Giant Bay repeated the test in June 1989 on a sample from the same source and obtained a gold recovery of 90.7% (Report No. 20). The bioleach procedure in both cases was similar and an identical degree of sulphide sulphur oxidation was achieved. The cyanidation procedure, however, was quite different, as outlined below:

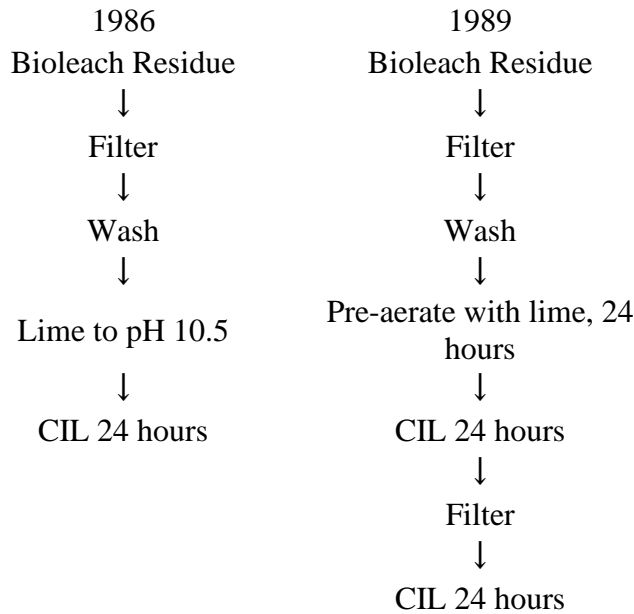

It was concluded that the improvement in results was probably due to the different cyanidation procedure and that a similar improvement might be obtained if the same procedure was applied to pressure oxidation or Arseno (now called Redox) process residues. Wright and Bacon, Donaldson & Associates designed a test work program to investigate this.

In summary, the test work program was as follows:

Confirmation Testing

Batch Float:	Zone 7 Composite
Bioleach:	Zone 7 Composite

The purpose of this work was to confirm the 1989 Giant Bay work and was carried out in March 1990 as outlined below.

Alternative Process Testing

Bulk Float:	Zone 7 Composite
Bioleach Program:	Zone 7 Composite
Pressure Oxidation Program:	Zone 7 Composite

Redox Process Program:

Zone 7
Composite

Neutralization with flotation tails

This program would have required one ton of Zone 7 mineralized material and one ton of a composite of Zones 5, 6 and 7 mineralized material to produce the necessary concentrates. The work was not carried out due to high cost. Confirmatory bioleach work was conducted on two freshly prepared concentrates: 1) produced from a composite of Zones 5, 6 and 7 mineralized material; and 2) the other from Zone 7 mineralized material alone (Report No. 21). Flotation results are summarized in Table 13.23.

Products	% Wt		Au oz/ton		% Distribution	
	Composite	Zone 7	Composite	Zone 7	Composite	Zone 7
Rougher Conc.	8.74	10.03	0.638	0.488	91.1	86.5
1 st Cleaner Conc.	8.21	2.73	0.678*	1.701	91.8	82
1 st Cleaner Tail	0.53	7.3	0.029	0.035	0.3	4.5
2 nd Cleaner Conc.	2.03	1.89	2.3	2.356*	76.3	78.9
2 nd Cleaner Tail	6.17	0.84	0.144	0.214	14.5	3.2
Final Tail	91.26	89.97	0.006	0.009	8.9	13.5
Calc. Head	100	100	0.061	0.057	100	100
Assay Head			0.054	0.055		

* Material used for bioleaching.

A five-litre batch bioleach test was conducted on each sample. To initiate each test, the slurry pH was lowered to 2 with sulphuric acid and an active culture of thiobacillus ferrooxidans added. The leach progress was followed by daily monitoring of pH, redox potential and dissolved oxygen. Details are summarized in Table 13.24.

Parameter	Composite	Zone 7
Initial Pulp Density (g/L)	100	52.9
H ₂ SO ₄ consumption (kg/t)	48.3	31.8
Leach Time (days)	18	14
Weight Loss (%)	20.6	70.7
S ₂ Oxidation (%)	92.4	97.3
Head Assays:		
Au (oz/ton)	0.678	2.356
Fe (%)	10.6	29.2
As (%)	1.04	Not determined
S ₂ (%)	8.35	35.82

The cyanidation procedure duplicated what was utilized by Giant Bay Biotech in June 1989. Gold recoveries were 91.2 and 93.7% for the composite and Zone 7 products, respectively. The respective sodium cyanide consumptions were 9.96 kg/t concentrate and 48.83 kg/t concentrate.

Wright Engineers determined that continuous leach residence times of 100 to 120 hours would be required.

13.4.9 Heap Leaching of Oxide Mineralized Material

Limited leaching test work was conducted on the Pine Tree oxide materials by Bacon, Donaldson & Associates (Report No. 22). The work consisted of one series of bottle roll tests and one series of column leach tests on samples of each of Zones 5, 6 and 7. The samples are described in Bacon, Donaldson & Associates' report as follows in Table 13.25.

Sample	Grind (%) (-200 No.)	Au Assay, Head (oz/ton)	Calc. Au Head (oz/ton)	Tailing Au (oz/ton)	Au Extraction (%)	Initial NaCN Conc. (g/L)	NaCN Consumption (lb/ton)	Lime Consumption (lb/ton)
Zone 5	19.3	0.0140	0.0499	0.0035	93.0	1.0	0.92	1.12
Zone 6	32.9	0.0440	0.0519	0.0041	92.3	1.0	1.76	22.78
Zone 7	43.7	0.0630	0.0755	0.0125	83.4	1.0	0.94	11.15

The results showed reasonable gold extractions with moderate cyanide consumptions, with high lime consumptions for Zones 6 and 7. The large discrepancy in the assay head and calculated head for Zone 5 is consistent with the sample description, which indicated the presence of free gold. The Zone 7 mineralized material showed signs of preg robbing. A gold extraction of 87.6% was

reported after 6 hours leaching compared to 83.4% after 24 hours. Column testing was conducted on material crushed to minus 2 inches. Test conditions were as follows in Table 13.26.

Sample	Sample Wt. (lb)	Column Diameter (in)	Column Height (in)	Initial NaCN Conc'n (g/L)	pH Range	Solution Flow Rate (gpm/ft²)
Zone 5	33.0	4	66.5	1.0	10.2 to 10.6	0.03
Zone 6	33.0	4	61.0	1.0	10.0 to 10.6	0.03
Zone 7	30.0	4	70.0	1.0	10.3 to 10.7	0.03

Note: Conc'n = concentrate, gpm = gallons per minute.

The Zone 7 mineralized material contained argillite, which swelled and plugged the column immediately when the solution was applied. The material was removed from the column and agglomerated by hand with the addition of 10.0 lb/ton (5 kg/t) of Portland cement. The test then proceeded satisfactorily.

The Zone 5 and 6 samples were each leached for 6 days, and then the columns allowed to drain between days 6 and 9. The columns were drained again between days 12 and 16 and the solutions partially stripped of gold using activated carbon between days 16 and 17. The stripped solution was subsequently circulated through the columns for two additional days before the tests were terminated. The Zone 7 mineralized material was leached for 35 days without interruption. The results are given in Table 13.27 and illustrated in Figures 13.1a and 13.1b.

Sample	Material Top Size (in)	Test Duration (Days)	Calc. Head Grade Au (oz/ton)	Residue Au (oz/ton)	Au Extraction (%)	Consumption	
						NaCN (lb/ton)	Lime (lb/ton)
Zone 5	2	19	0.0286	0.0035	88.1	3.2	1.7
Zone 6	2	19	0.0248	0.0058	78.8	3.3	12.0
Zone 7	2	35	0.0830	0.0175	79.2	3.1	10.8

The plots of gold extraction versus time show that extraction in all cases was complete after six days. The Zone 7 mineralized material exhibited preg robbing after 16 days, after which extraction decreased from 85 to 79%. The Zone 6 and 7 mineralized materials showed high lime consumption, in-line with the bottle roll tests. Cyanide consumption for all three materials, however, was high and in the range 3.1 to 3.3 lb/ton (1.55 to 1.65 kg/t).

The above tests were used by Wright for the preliminary design of a heap leach facility. A report entitled "Pine Tree Project, Heap Leach Prefeasibility Study" was issued in January 1989.

FIGURE 13.1 OXIDE MATERIAL COLUMN LEACH TEST RESULTS
A) ZONE 5• AND ZONE 6+

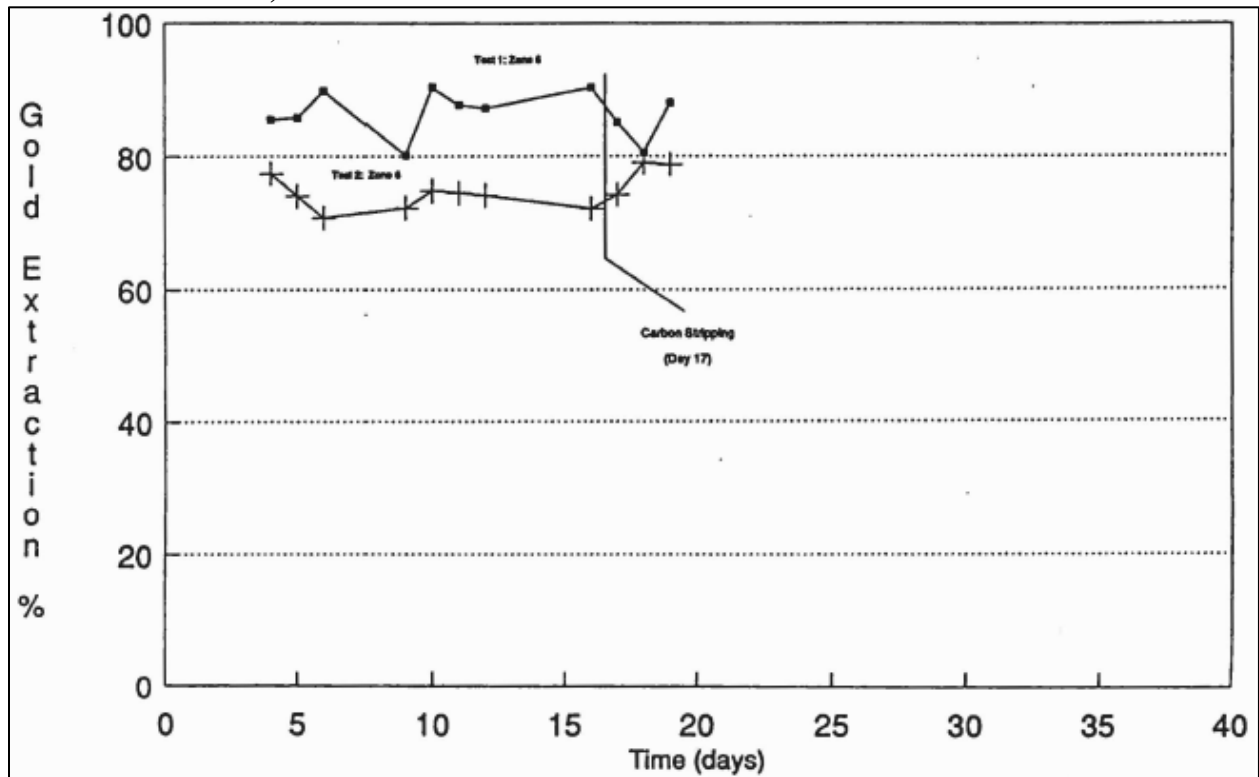

B) ZONE 7*

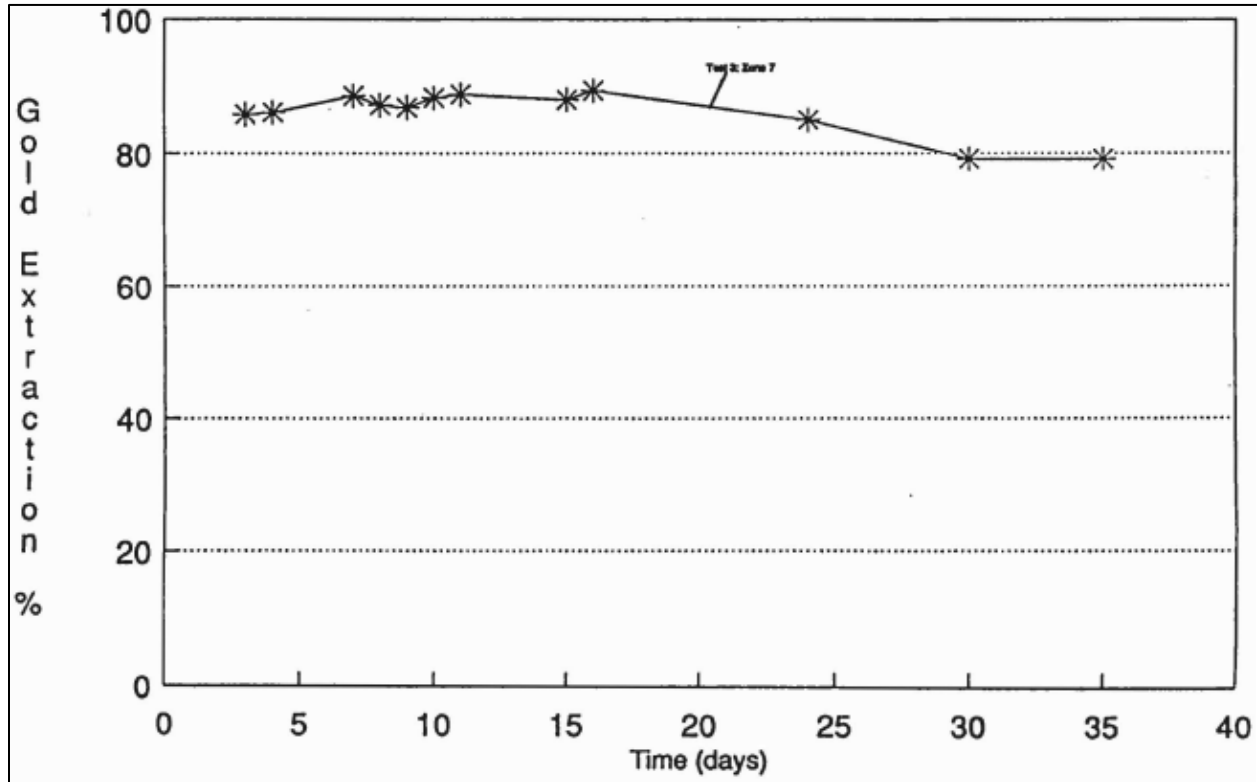

Source: Bacon, Donaldson & Associates (1986)

13.5 2014 TEST WORK

In 2014, new mineralized samples were collected and sent to Inspectorate Exploration & Mining Services Ltd. (“Inspectorate”) for evaluation. Split drill core along with some rock pieces from 109 different samples were utilized for creating the three different composites used for testing. The samples in this program included four drill holes near the south end of the Pine Tree-Josephine Deposit.

Three metallurgical domains were identified and composited as follows:

1. Oxide Cap Mineralization (OXC Composite);
2. Sulphide Replacement Mineralization (SRM Composite); and
3. Quartz-hosted Gold Mineralization (QTZ Composite).

The head analysis of these composites is presented in Table 13.28.

TABLE 13.28 HEAD ANALYSIS				
Element	Unit	Composite Analysis		
		OXC	QTZ	SRM
Au	g/t	2.19	3.74	2.79
Ag	g/t	1.5	1.2	1.4
Hg	g/t	0.07	0.05	0.11
C (total)	%	0.62	1.3	2.07
C (graphitic)	%	0	0	0.01
S (total)	%	0.02	0.86	1.88

Note: OXC = Oxide, QTZ = quartz, SRM = sulphide replacement material.

13.5.1 Comminution Testing

Samples from the SRM and QTZ composites were tested for hardness using the Bond Ball Mill Work Index test. The results are presented in Table 13.29.

TABLE 13.29 BALL MILL BOND WORK INDEX		
Material	Amount	Unit
SRM Composite	11.2	kWh/ton
	12.3	kWh/tonne
QTZ Composite	13.0	kWh/ton
	14.3	kWh/tonne

Note: QTZ = quartz, SRM = sulphide replacement material.

These results indicate a medium range hardness of the mineralized composite samples.

13.5.2 Flotation Tests

13.5.2.1 Rougher Flotation Kinetic Tests

Rougher flotation kinetic tests were completed on the SRM and QTZ composites. Two rougher circuit flotation tests were conducted on each composite at grinds of 150 and 75 µm to identify the effect of grind size on grade and recovery. A one-minute pre-float utilizing only frother (MIBC) was performed with the objective to remove any naturally floating carbonaceous material. Following the pre-float, four timed rougher concentrates were produced and analyzed separately. The results are summarized in Table 13.30.

TABLE 13.30
ROUGHER FLOTATION KINETICS VERSUS GRIND SIZE

Composite	Grind	Assays			Rougher Recovery		
	P ₈₀ (µm)	Au (g/t)	Ag (g/t)	S (%)	Au (%)	Ag (%)	S (%)
SRM	150	16.2	8.1	9.2	95.9	78.7	92.1
SRM	74	14.6	6.7	8.6	95.4	77.3	93.6
QTZ	153	33.4	13.3	6.9	95.6	78.4	95.9
QTZ	76	23.7	7.6	5	95.9	74.1	96.9

Note: QTZ = quartz, SRM = sulphide replacement material.

The grind size appeared to have little effect on the metallurgical grade or recovery. All additional test work was completed at the 150 µm grind size.

The metallurgical relationships found in the rougher flotation stage are illustrated in Figure 13.2.

FIGURE 13.2 ROUGHER FLOTATION KINETIC RELATIONSHIPS

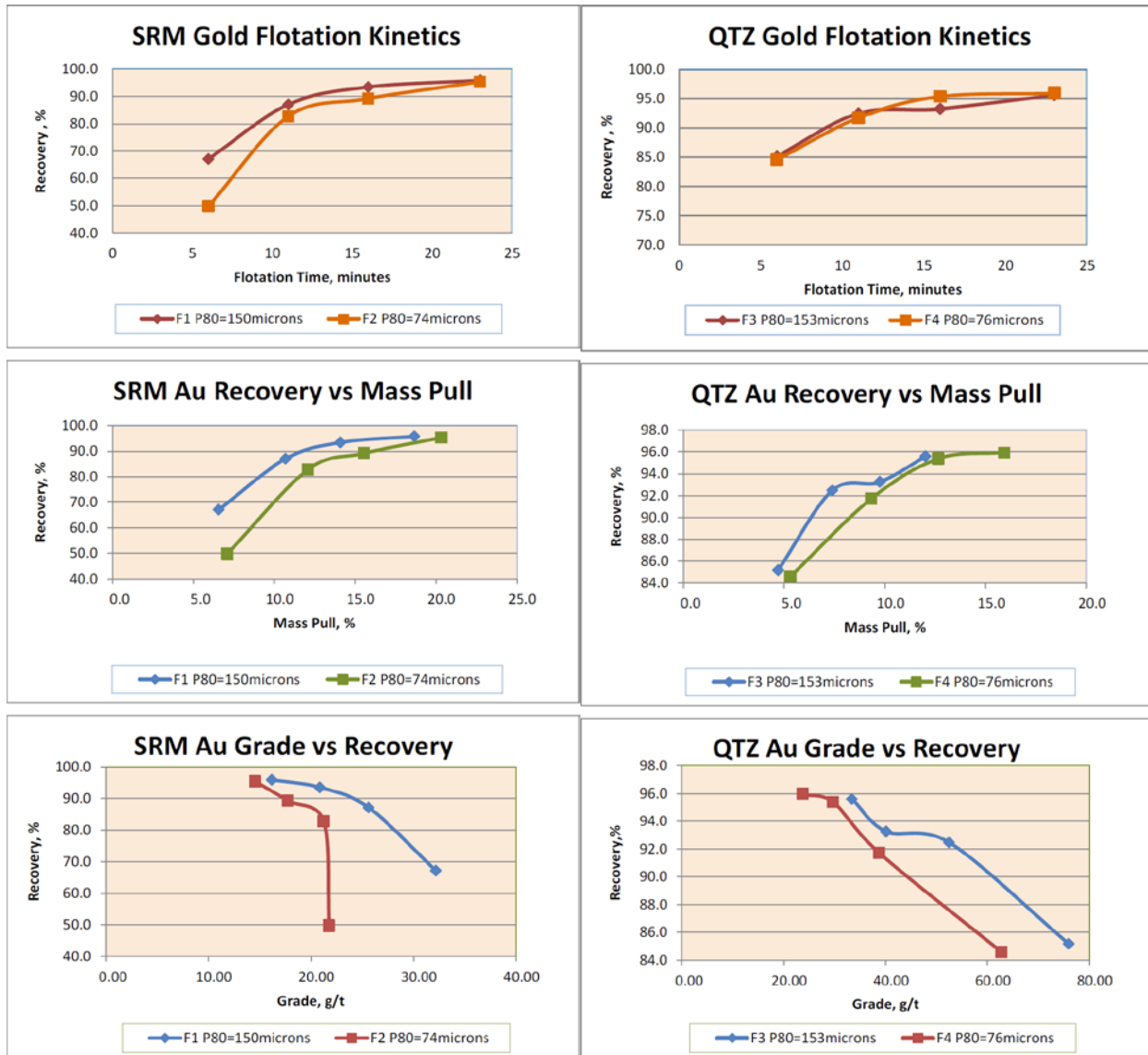

Source: Inspectorate (2014)

13.5.2.2 Rougher-Cleaner Circuit Flotation Tests

A single rougher-cleaner circuit test was conducted on each of the SRM and QTZ composites at a primary grind of 150 µm. The rougher concentrate was reground to approximately 30 µm before going to cleaner flotation at a natural pH. The SRM and QTZ cleaner tests produced Au recoveries of 72.9 and 79.5%, respectively. The metallurgical results are presented in Table 13.31.

**TABLE 13.31
CLEANER CIRCUIT FLOTATION METALLURGY**

Comp	Feed Grade		Ro Con	Regrind	3 rd CC	3 rd Cleaner Concentrates			Cleaner Circuit % Recovery			Total Circuit % Recovery		
	Au (g/t)	Ag (g/t)	Wt (%)	P ₈₀ (µm)	Wt (%)	Au (g/t)	Ag (g/t)	S (%)	Au	Ag	S	Au	Ag	S
SRM	2.69	1.8	16.5	30	2.6	71.4	41	38.9	72.9	79.5	59.8	68.8	60.6	53.9
QTZ	3.87	1.9	10.3	24	1.4	214.8	85	40.9	83.9	85.8	71.9	79.5	65.2	67.4

Note: Comp = Composite, Ro Con = rougher concentrate, CC = cleaner concentrates, QTZ = quartz, SRM = sulphide replacement material.

13.5.3 Gravity Concentration

Gravity concentration tests were conducted at 150 µm for both composites utilizing a laboratory Knelson centrifugal gravity separator. A double pass through the concentrator was followed by an upgrading stage. The results of the gravity separation between both composites are different, likely due to the mineralogical difference and amount of available free gold. The results are presented in the Table 13.32.

Product	Mass Pull (%)	Assay		Distribution	
		Au (g/t)	Ag (g/t)	Au (%)	Ag (%)
SRM Concentrate	7.4	27.63	10.4	69.5	62.6
QTZ Concentrate	7.1	37.57	20.7	76.7	75.9

Note: QTZ = quartz, SRM = sulphide replacement material.

13.5.4 Combined Gravity Separation and Flotation Tests

Tests were conducted on the SRM and QTZ composites combining the centrifugal gravity separation process and a full flotation circuit. Both samples were ground to the nominal 150 µm. The combination of gravity separation followed by a rougher-cleaner flotation circuit with a regrind stage produced highly encouraging results, as summarized in the Table 13.33.

Circuit	Au (g/t)	Ag (g/t)	Au Recovery (%)	Ag Recovery (%)
SRM Composite				
Gravity Concentrate	229.5	51.1	7.0	2.5
Flotation Concentrate	54.5	29.0	78.6	66.6
Total	58.1	29.5	85.6	69.1
QTZ Composite				
Gravity Concentrate	1,636.0	853.0	38.6	31.7
Flotation Concentrate	84.7	43.0	55.0	43.9
Total	139.0	71.4	93.6	75.6

Note: QTZ = quartz, SRM = sulphide replacement material.

13.5.5 Cyanidation Tests

13.5.5.1 Bottle Roll Direct Cyanide Leach Tests

A 10-day coarse bottle roll cyanidation leach test was conducted on 50 kg of minus 25 mm (1 in) material from the OXC composite. The test was run at a pH of 10.5 with 1.0 g/L NaCN. The gold and silver leached rapidly for 48 hours, slowed for approximately 70 hours and later resumed leaching. At the end of ten days, 93% of the gold and 75% of the silver had been extracted, as demonstrated in Figure 13.3.

FIGURE 13.3 OXC COARSE BOTTLE ROLL LEACH KINETICS

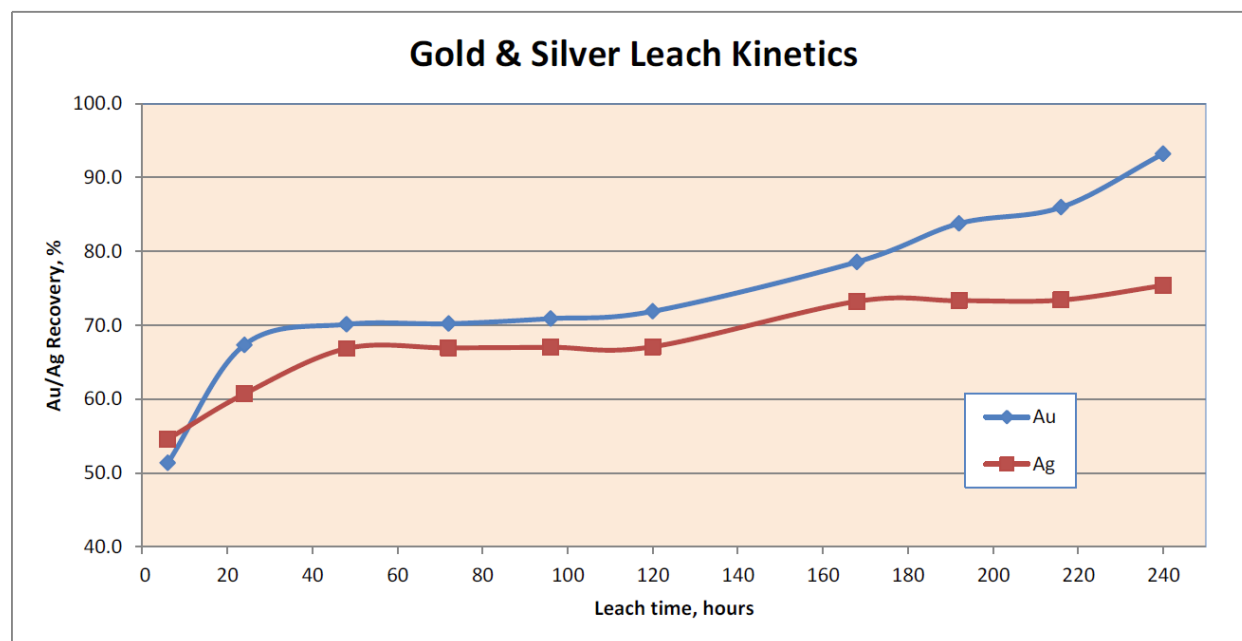

Note: OXC = oxide.

Source: Inspectorate (2014)

A single 72-hour cyanidation test was run on both the SRM and QTZ composites at the nominal grind of 150 µm. The tests were run at 40% solids, pH 10.5, and 1.0 g/L NaCN. The two mineralized material types were not found to be amenable to the cyanidation process. The results are presented in Table 13.34.

Composite	Extraction	
	Au (%)	Ag (%)
SRM	<0.5	7.3
QTZ	4.7	31.9

Note: QTZ = quartz, SRM = sulphide replacement material.

13.5.5.2 Bottle Roll Carbon-in-Leach (CIL) Tests

Two carbon-in-leach (CIL) tests were conducted on the SRM and QTZ composites at the nominal grind of 150 microns. The recoveries were improved over the direct bottle rolls. The results are presented in Table 13.35.

TABLE 13.35 SRM AND QTZ CIL RESULTS	
Composite	Au Extraction (%)
SRM	10.4
QTZ	38.2

Note: QTZ = quartz, SRM = sulphide replacement material, CIL = carbon-in-leach.

13.6 CONCLUSIONS

The historical operations consistently achieved gold recoveries averaging 88.5% with a combined flotation and gravity circuit, as shown in Table 13.1. The locked-cycle test results presented in Table 13.14 show a flotation recovery of 91.3% on a composite sample of Zones 5, 6 and 7. In June/July 1987, Beacon Hill achieved a flotation gold recovery of 89.7% on the composite underground bulk sample.

For the 2014 iteration of test work, the samples were grouped by different metallurgical domains, including SRM and QTZ, for treatment by gravity and flotation. The 2014 Combined Gravity and Flotation recovery for the SRM is 85.6% for gold and 69.1% for silver. The 2014 Combined Gravity and Flotation recovery for the QTZ is 93.6% for gold and 75.6% for silver.

The flotation concentrate was not amenable to cyanidation without further processing. The roasting process was the most effective oxidation process tested for the recovery of gold. Roasting tests were not conducted on the SRM and QTZ samples. However, there has been extensive roasting test work completed and the cyanide leaching of the roasted product (calcine). The tests in the scoping work achieved 92.7% gold recovery and in the pilot campaign conducted by Lurgi achieved 90% gold recovery in cyanidation of the calcine.

There are likely to be metal losses in the roaster, and therefore it is assumed that 97% of the metal sent to the roaster is available for recovery.

The coarse bottle roll on the OXC achieved a gold recovery of 93% in ten days of leaching minus 1 inch material, which confirms that the OXC has reasonable potential for heap leaching. The column leach tests on Zone 5, Zone 6, and Zone 7 oxide cap yielded gold recoveries of 88.1%, 78.8%, and 79.2%, respectively. Since each zone has an oxide cap on the surface, an average laboratory recovery of 82.0% is a reasonable starting point. The estimated process and recoveries are presented in Table 13.36.

TABLE 13.36
METALLURGICAL PROCESSES AND ESTIMATED RECOVERIES

Material	Process	Estimated Final Recovery	
		Au (%)	Ag (%)
SRM	Mill, Gravity, Float, Roast, Cyanidation	74.7	60.3
QTZ	Mill, Gravity, Float, Roast, Cyanidation	81.7	66.0
OXC	Heap Leach	82	

Note: OXC = oxide, QTZ = quartz, SRM = sulphide replacement material.

14.0 MINERAL RESOURCE ESTIMATES

14.1 INTRODUCTION

The Mineral Resource Estimate presented herein is reported in accordance with the Canadian Securities Administrators' National Instrument 43-101 (2014) and is consistent with generally accepted CIM "Estimation of Mineral Resources and Mineral Reserves Best Practices" guidelines (2019). Mineral Resources are not Mineral Reserves and do not have demonstrated economic viability. There is no guarantee that all or any part of the Mineral Resource will be converted into a Mineral Reserve. Confidence in the estimate of Inferred Mineral Resources is insufficient to allow the meaningful application of technical and economic parameters or to enable an evaluation of economic viability worthy of public disclosure. Mineral Resources may be affected by additional sampling, infill and exploration drilling that may result in increases or decreases in subsequent Mineral Resource Estimates.

All Mineral Resource estimation work reported herein was carried out by Messieurs Fred Brown, P.Geo., and Eugene Puritch, P.Eng., FEC, CET both of P&E Mining Consultants Inc. and independent Qualified Persons in terms of NI 43-101 by reason of education, affiliation with a professional association, and past relevant work experience. A draft copy of this Report has been reviewed by Stratabound for factual errors.

Mineral Resource modelling and grade estimation was carried out using GEOVIA GEMS™, Leapfrog™ and Snowden Supervisor™ software. Pit optimization was conducted using NPV Scheduler™.

The Authors are not aware of any environmental, permitting, legal, title, taxation, socio-economic, marketing, political, or other relevant factors that could materially affect the Mineral Resource Estimate.

14.2 DATA SUPPLIED

Drilling and sampling data were supplied by Stratabound in digital format. The database supplied by Stratabound contains 3,444 unique collar records incorporating diamond drill holes, RC drill holes, trench sampling, and underground channel sampling (Figure 14.1). The database contains drill hole collar, downhole survey, assay, lithology and bulk density tables. The Project coordinate reference system is NAD83 UTM Zone 10N (EPSG 26910).

FIGURE 14.1 SURFACE DRILLING AND TRENCHING

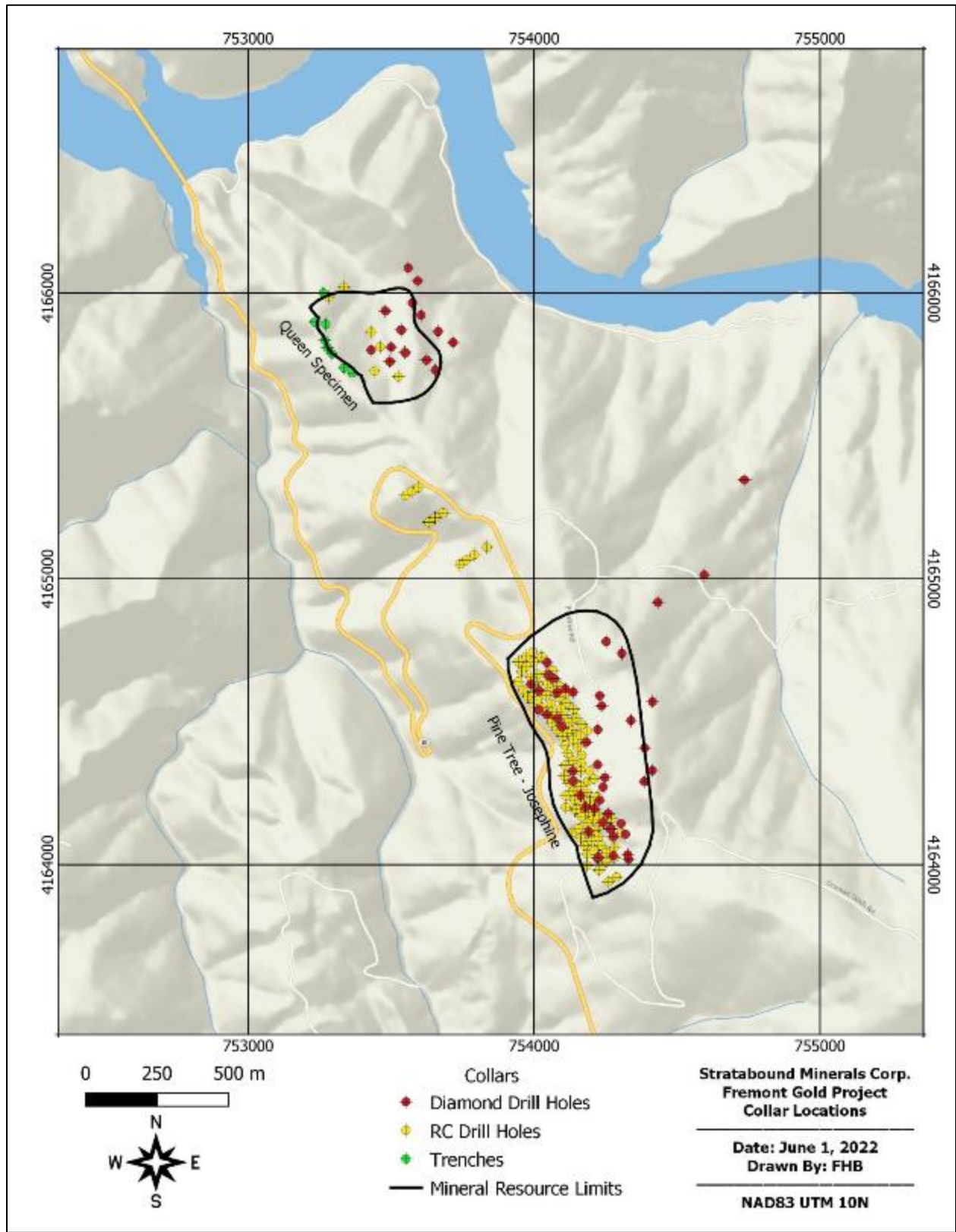

For the client-supplied database, 24 drill holes are outside the model extents, two drill holes have repetitive assay intervals and were not included in the Mineral Resource Estimate, and four drill holes have no assay data. The Mineral Resource Estimate used a total of 3,414 unique collar records (Table 14.1). These drill holes are shown in plan view in Appendix A.

TABLE 14.1 DATABASE SUMMARY		
Drill Hole Type	Record Count	Total Metres
UG Channel Samples	3,212	5,760.36
RC Drill Holes	118	17,035.02
DD Drill Holes	76	16,946.86
Surface Trenches	8	518.10
Total	3,414	40,260.34

14.3 DATABASE VALIDATION

Industry standard validation checks were completed on the client-supplied database. The database was validated by checking for inconsistencies in naming conventions or analytical units, duplicate entries, interval, length or distance values less than or equal to zero, blank or zero-value assay results, out-of-sequence intervals, intervals or distances greater than the reported drill hole length, inappropriate collar locations, and missing interval and coordinate fields.

A total of eight surface trenches developed by Stratabound were incorporated with the Queen Specimen Mineral Resource Estimate. The Authors note that a number of the trenches were developed in soil horizons and (or) saprolite (Figure 14.2). The soil samples in the Project area are primarily “extremely rocky clay loams”¹, and the Authors recommend that this type of sampling be limited to geochemical exploration in the future.

¹ National Cooperative Soil Survey data, downloaded June 16, 2022.

FIGURE 14.2 SURFACE TRENCH QS-TR-22-01NW



Source: Stratabound (2022)

Former Project operator, California Gold, completed a total of 21 diamond drill holes between 2017 and 2018 in the Queen Specimen area. The Authors note that collar locations for these drill holes were located using a handheld GPS, and in six cases have duplicate locations. It is recommended that all future drill hole collars be located by a licensed land surveyor.

Additional drilling includes 140 RC drill holes completed by an earlier Project operator Goldenbell between 1985 and 1986 on the Property, and 61 diamond drill holes completed by California Gold between 2013 and 2016 at Queen Specimen (5 holes), French Mine (4 holes), and Pine Tree-Josephine (52 holes). A total of 17 of the California Gold drill holes have duplicate collar locations (2 at French Mine and 15 at Pine Tree-Josephine). 14 of the 15 duplicate collar locations at Pine Tree-Josephine reflect the 2013 twinning drill hole program (see Section 10). The Authors are satisfied that the historical drill hole data are suitable for use in preparation of a Mineral Resource Estimate.

Underground channel assay data were compiled by California Gold from historical records (Figures 14.3 and 14.4). Historical sample data were listed using only two significant digits for the original ounce/short ton grades. The historical data were converted to g/t, which represents a reduction in the accuracy of the historical data. The Authors reviewed copies of the historical

FIGURE 14.4 UNDERGROUND DEVELOPMENT AND SAMPLING

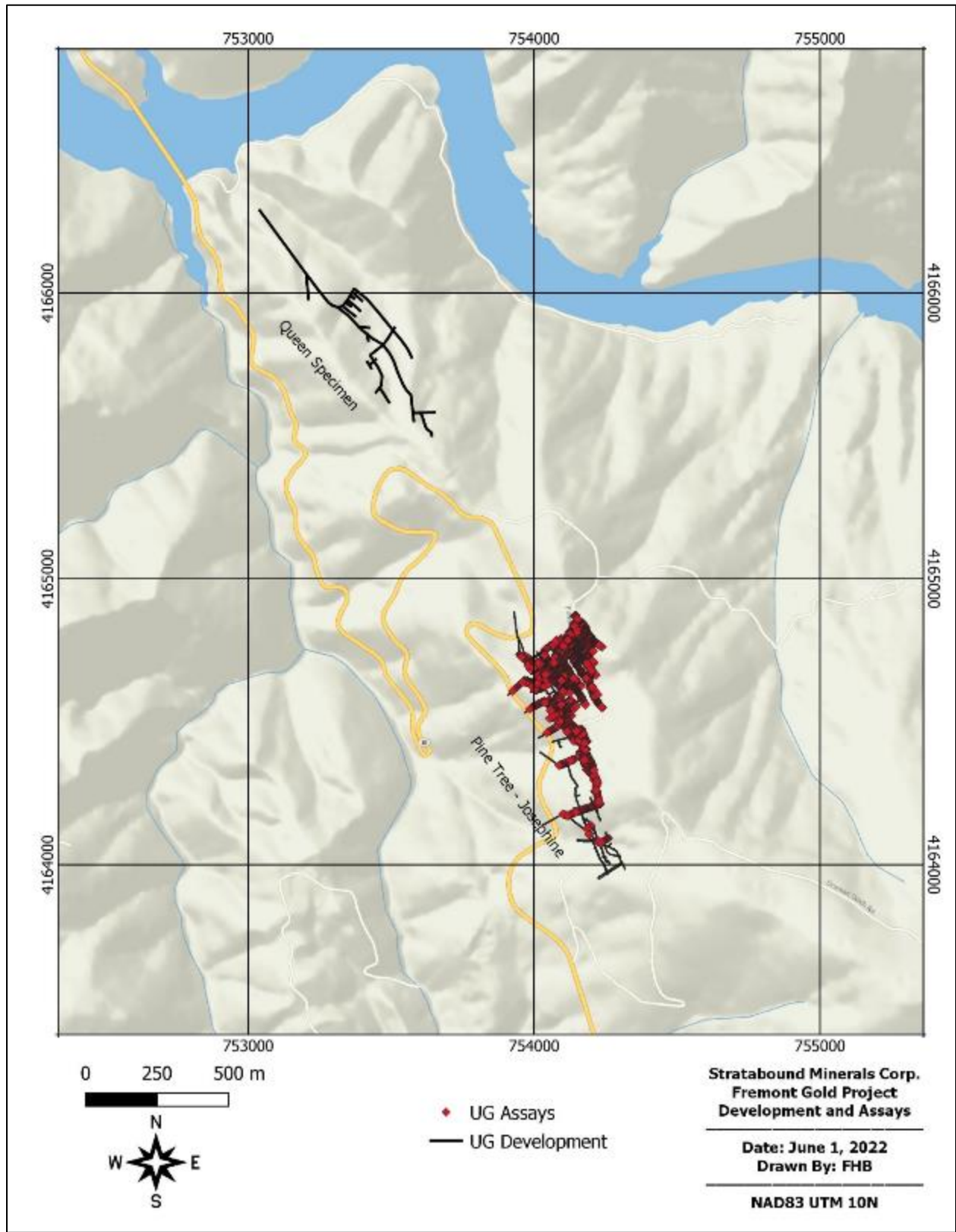

14.4 ECONOMIC ASSUMPTIONS

This Mineral Resource Estimate incorporates the economic assumptions listed in Table 14.2.

TABLE 14.2 ECONOMIC PARAMETERS				
Item	Unit	Heap Leach	Open Pit	Underground
Gold Price	US\$/oz	1,700	1,700	1,700
Heap Leach Recovery	%	85		
Process Plant Recovery	%		90	90
Open Pit Mining Cost, Mineralized Material and Waste Rock	\$/t	3.00	3.00	
Underground Mining Cost	\$/t			40.00
Heap Leach OPEX	\$/t	9.16		
Process Plant OPEX	\$/t		10.02	10.02
G&A OPEX	\$/t	2.50	2.50	2.50
Royalty NSR	%	3	3	3
Smelter/Refining Payable	\$/oz Au		99	99
Heap Leach Refining Payable	%	99		
Open Pit Heap Leach Oxide Cut-off Grade	g/t Au	0.25		
Open Pit Sulphide Cut-off Grade	g/t Au		0.45	
Out-of-Pit Sulphide Cut-off Grade	g/t Au			1.45

Note: all \$ values are in US\$.

14.5 DOMAIN MODELLING

A series of grade estimation domains for the Fremont deposits based on the deposit geology and metallurgical responses were generated. Grade estimation domains are based on the following criteria. The primary serpentinite and sedimentary units have been overprinted by the Melones Fault structural deformation as manifested by the “melange” as the over-riding structural control for subsequent gold deposition. This has prepared the ground for gold emplacement by:

- a) Two principal steep-dipping HW and FW dilatant fracture hosts for gold-bearing free and flotation/CN amenable gold in quartz veins that track more or less along, within and without the FW and HW of the melange. The melange itself is akin to a breccia and is composed of serpentinites, sediments and a diorite country rock;
- b) Lateral sulphide replacement gold mineralization (“SRM”) penetrating outwards as halos from the veins and lithological boundaries. This style of mineralization is not free milling nor amenable to cyanidation and is refractory. The ground preparation for this style of mineralization can be hosted in melange, serpentinite or sediments and occurs as halos either side of structural features whether they be quartz veins or lithological boundaries; and

- c) Melones Melange contacts in the footwall and hanging wall should not be considered “hard” boundaries. The SRM mineralization wanders along, within, without and either side of these contacts as it does with the primary quartz veins.

The resulting grade estimation domains incorporate six distinct styles of mineralization:

1. Serpentinite Sulphide Replacement Mineralization.
2. Melange Sulphide Replacement Mineralization.
3. Hanging Wall Pine Tree Quartz Veining.
4. Footwall Josephine Quartz Veining.
5. Mariposa Metasedimentary Sulphide Replacement Mineralization.
6. Queen Specimen Metavolcanics.

Based on the grade estimation domains, a series of three-dimensional (3-D) wireframes were developed by the Authors as the basis of the Mineral Resource Estimate. The domain wireframes were developed primarily using logged lithologies to generate a stratigraphic sequence, as follows:

- Melange Sulphide Replacement Mineralization was extended into the upper serpentinite metavolcanics based on assay grades immediately adjacent to the contact;
- A Mariposa Sulphide Replacement Mineralization domain was modelled along the Melange contact;
- A lower Sulphide Replacement Mineralization domain was modelled within the Mariposa metasedimentary rocks, based on a 0.25 g/t Au assay grade cut-off;
- Quartz veins were modelled from historical development and drill hole logs as cross-cutting structures within and adjacent to the Melange Zone; and
- Two Queen Specimen domains were modelled using 0.25 g/t Au assay grade shells within the upper serpentinite metavolcanics.

A total of eight grade estimation domains were developed (Table 14.3) and used for block coding, statistical analysis, compositing limits, and grade estimation (Figure 14.5). The 3-D domains are presented in Appendix B.

TABLE 14.3 GRADE ESTIMATION DOMAIN ROCK CODES		
Domain	Description	Rock Code
HWQZ_250	Hanging Wall Quartz Veins	250
MEL_350	Melange Sulphide Replacement Mineralization	350
FWQZ_450	Footwall Quartz Veins	450
MAR_650	Upper Mariposa Sulphide Replacement Mineralization	650
MAR_655	Lower Mariposa Sulphide Replacement Mineralization	655
PTJ_750	Serpentinite Sulphide Replacement Mineralization	750
QS_800	Upper Queen Specimen Metavolcanics	800
QS_850	Lower Queen Specimen Metavolcanics	850

FIGURE 14.5 GRADE ESTIMATION DOMAINS

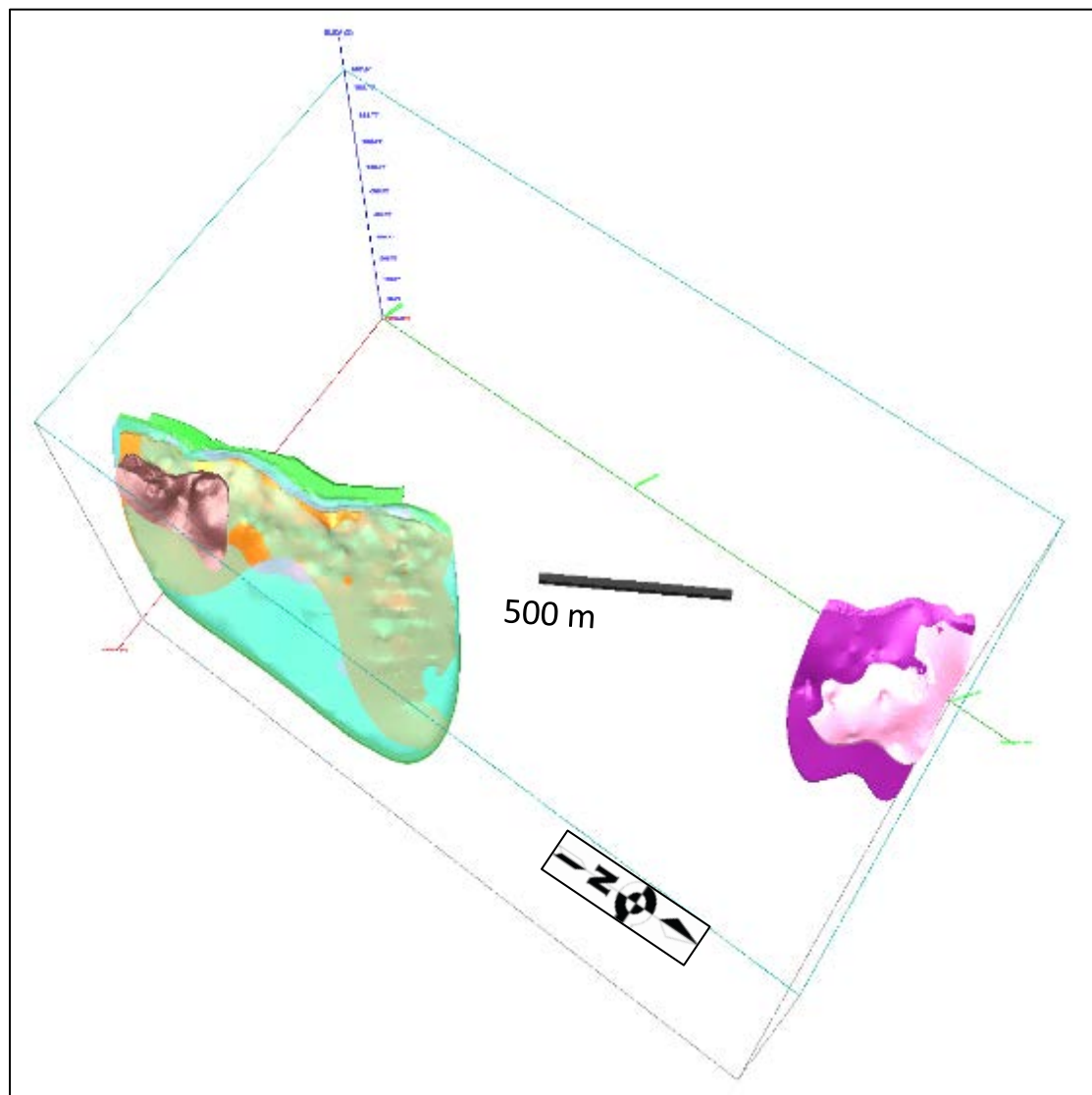

A topographic surface across the Property was generated from point LiDAR™ data supplied by Stratabound and incorporating surveyed drill hole collar elevations.

Stratabound supplied redox information compiled previously by California Gold. Oxidation states were determined and recorded on logs by Goldenbell staff for RC holes as percentage oxidation based on visual observation, and by California Gold staff semi-quantitatively by degree of oxidation recorded on both logs and from photographs of diamond drill hole core.

From the client-supplied redox data, the base of oxidation in the drill holes was identified by Stratabound geologists and used to model the base of the potential oxide zone across the Mineral Resource area. The quartz vein zones were also used to define a separate oxidation zone.

14.6 EXPLORATORY DATA ANALYSIS

The overall mean nearest neighbour collar distance for the surface drilling is 26 m. The average length of all diamond drill holes is 234.41 m, the average length of all RC drill holes is 141.96 m, and the average length of all underground channel samples is 1.79 m.

A total of 27,310 assay intervals are constrained within the defined grade estimation domains. Summary statistics for the constrained assay data are listed in Table 14.4.

TABLE 14.4						
SUMMARY STATISTICS FOR CONSTRAINED AU ASSAYS (G/T)						
Domain	Count	Minimum	Maximum	Avg	Std Dev	CoV
HWQZ 250	4,159	0.0001	128.91	3.62	8.61	2.37
MEL 350	11,187	0.0001	130.97	0.89	3.14	3.52
FWQZ 450	1,156	0.0001	43.03	3.55	4.55	1.28
MAR 650	3,269	0.0001	100.11	1.06	2.53	2.38
MAR 655	728	0.0001	7.95	0.40	0.89	2.24
PTJ 750	1,926	0.0001	34.73	0.29	0.97	3.35
QS 800	3,152	0.0001	22.91	0.30	0.97	3.24
QS 850	1,733	0.0001	27.64	0.15	0.82	5.62
Total	27,310	0.0001	130.97	1.27	4.31	3.40

Note: Avg = average, Std Dev = standard deviation, CoV = coefficient of variation.

Three pairs of drill holes are located within 3.0 m of each other. A comparison of DD and RC assay grades between the twin drill holes indicates a rough down-the-hole correlation, with a tendency for RC assay sample grades to be lower than the reported diamond drill hole grade for the same elevation (Figure 14.6).

FIGURE 14.6 TWIN DRILL HOLES ANALYSIS

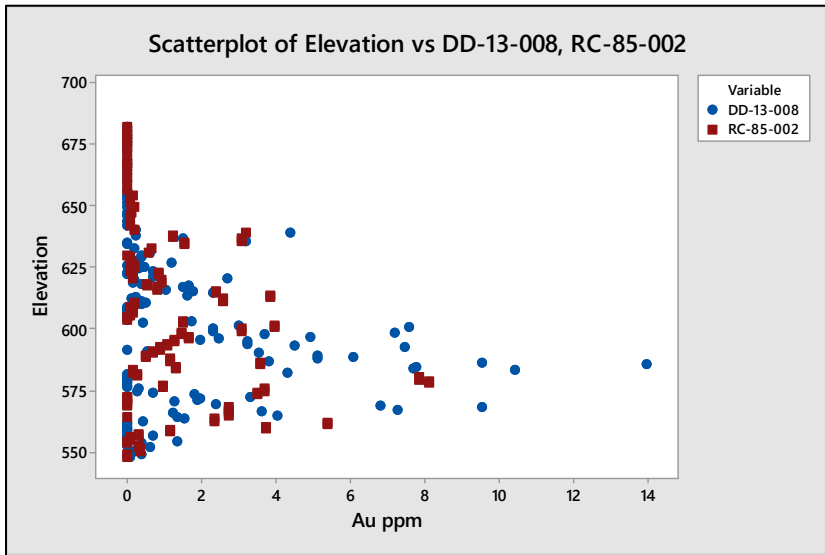
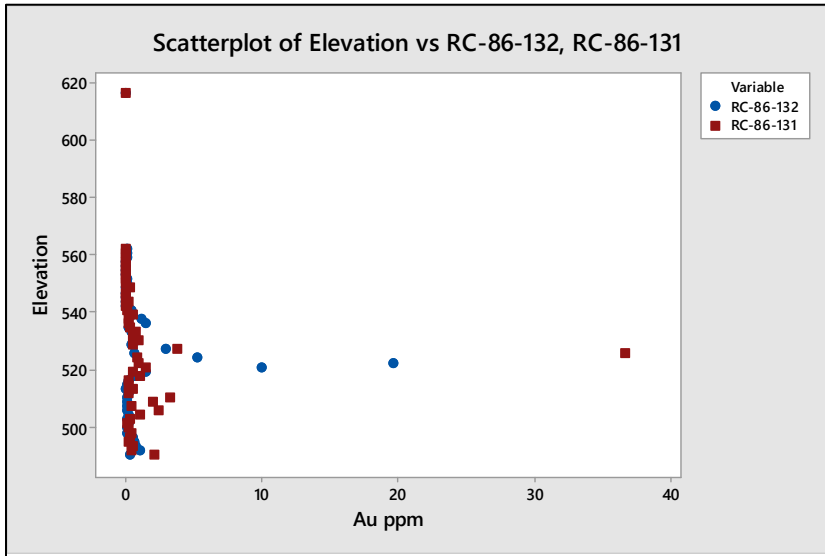
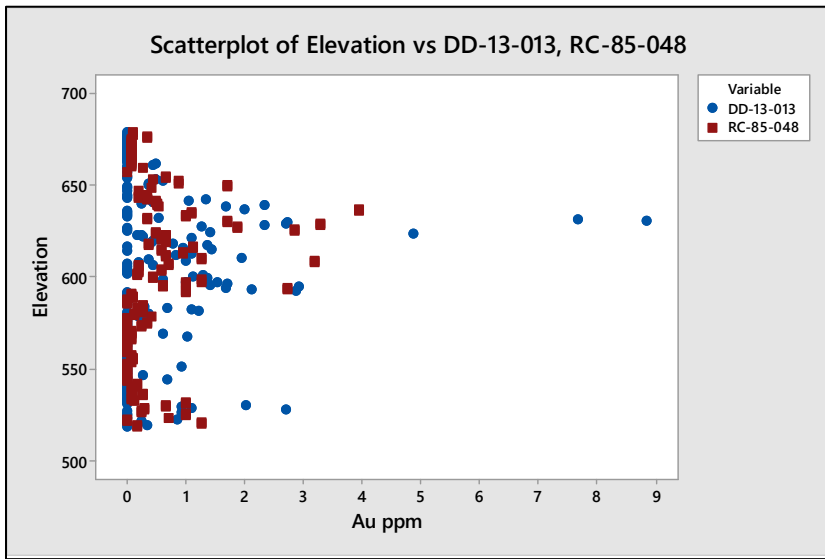

14.7 BULK DENSITY

California Gold reported a total of 1,045 bulk density measurements associated with diamond drill hole core, ranging from 1.93 t/m³ to 5.27 t/m³, with an average value of 2.76 t/m³.

The average and median bulk density values by oxidation zone are as follows:

- **Oxide:** average = 2.65 t/m³, median = 2.65 t/m³
- **Sulphide:** average = 2.78 t/m³, median = 2.73 t/m³
- **Quartz:** average = 2.72 t/m³, median = 2.68 t/m³.

Mineralized domain bulk density values were assigned based on the median value for each redox zone.

14.8 COMPOSITING

Constrained assay sample lengths for the Fremont assays range from 0.001 m to 24.70 m, with an average sample length of 1.36 m and a median sample length of 1.52 m. A total of 40% of the samples have a sample length of 1.52 m (5.00 ft). In order to ensure equal sample support, a compositing length of 1.52 m was therefore selected for use for Mineral Resource estimation.

Length-weighted composites were calculated within the defined grade estimation domains. The compositing process started at the first point of intersection between the drill hole and the domain intersected and halted upon exit from the domain wireframe. The wireframes that represent the interpreted domains were also used to back-tag a rock code into the drill hole workspace, and assays and composites were assigned a domain rock code value based on the domain intersected. A nominal grade of 0.001 g/t Au was used to populate a small number of un-sampled intervals. Residual composites that were <0.38 m were discarded, so as to limit the introduction of a short sample bias into the grade estimation process. The composite data were subsequently exported to extraction files for analysis and grade estimation.

14.9 COMPOSITE DATA ANALYSIS

Summary statistics for the composited samples were calculated within the defined grade estimation domains (Table 14.5).

Domain	Count	Minimum	Maximum	Avg	Std Dev	CoV
HWQZ 250	2,440	0.0001	121.37	4.58	7.97	1.74
MEL 350	5,674	0.0001	130.97	1.61	3.40	2.10
FWQZ 450	916	0.0001	31.89	3.94	4.27	1.08
MAR 650	1,815	0.0001	100.11	1.79	3.27	1.83
MAR 655	216	0.0001	7.05	1.03	1.25	1.21

TABLE 14.5						
GRADE ESTIMATION DOMAIN COMPOSITE AU SUMMARY STATISTICS (G/T)						
Domain	Count	Minimum	Maximum	Avg	Std Dev	CoV
PTJ 750	614	0.0001	33.15	0.64	1.47	2.31
QS 800	607	0.0001	19.16	1.13	1.69	1.50
QS 850	139	0.005	16.92	1.05	1.82	1.74
Total	12,421	0.0001	130.97	2.30	4.76	2.07

As a check on potential sample bias between data types, a series of QQ plots were constructed between diamond drill holes (“DD”), reverse circulation drill holes (“RC”), underground channel samples (“UG”) and trench (“TR”) composite samples (Figure 14.7).

The Authors note the following results for the type of samples:

- For the Hanging Wall Quartz Veins (HWQZ_250) the DD and RC samples display a reasonable correlation except at low grades;
- For the Hanging Wall Quartz Veins (HWQZ_250) the DD samples underestimate the grade compared to the UG samples. This may be caused by the large number of channel samples taken within the high-grade quartz vein compared to the scattered drill hole samples;
- For the Footwall Quartz Veins (FWQZ_450) the DD and RC samples display a reasonable correlation except at low grades;
- For the Footwall Quartz Veins (FWQZ_450) the DD samples underestimate the grade compared to the UG samples. This may be caused by the large number of channel samples taken within the high-grade quartz vein compared to the scattered drill hole samples;
- For the Melange Zone (MEL_350) the RC samples underestimate the grade slightly compared to the DD samples;
- For the Melange Zone (MEL_350) the DD samples underestimate the grade compared to the UG samples;
- For the Mariposa Zone (MAR_650) the DD and RC samples display a reasonable correlation except at low grades;
- For the Mariposa Zone (MAR_650) the DD samples underestimate the grade compared to the RC samples;
- For the upper Queen Specimen Zone (QS_800) the DD and RC samples display a reasonable correlation;

- For the upper Queen Specimen Zone (QS_800) the Trench samples underestimate the grade compared to the DD samples; and
- For the Pine Tree-Josephine Serpentinite Zone (PTJ_750) the DD and RC samples display a reasonable correlation.

The Authors note that there is minimal bias between DD and RC samples. However, UG channel sample grades are consistently higher than DD sample grades within the same domain, possibly a result of the large number of channel samples associated directly with mineralization identified underground.

FIGURE 14.7 **QQ PLOTS**
(11 Figures)

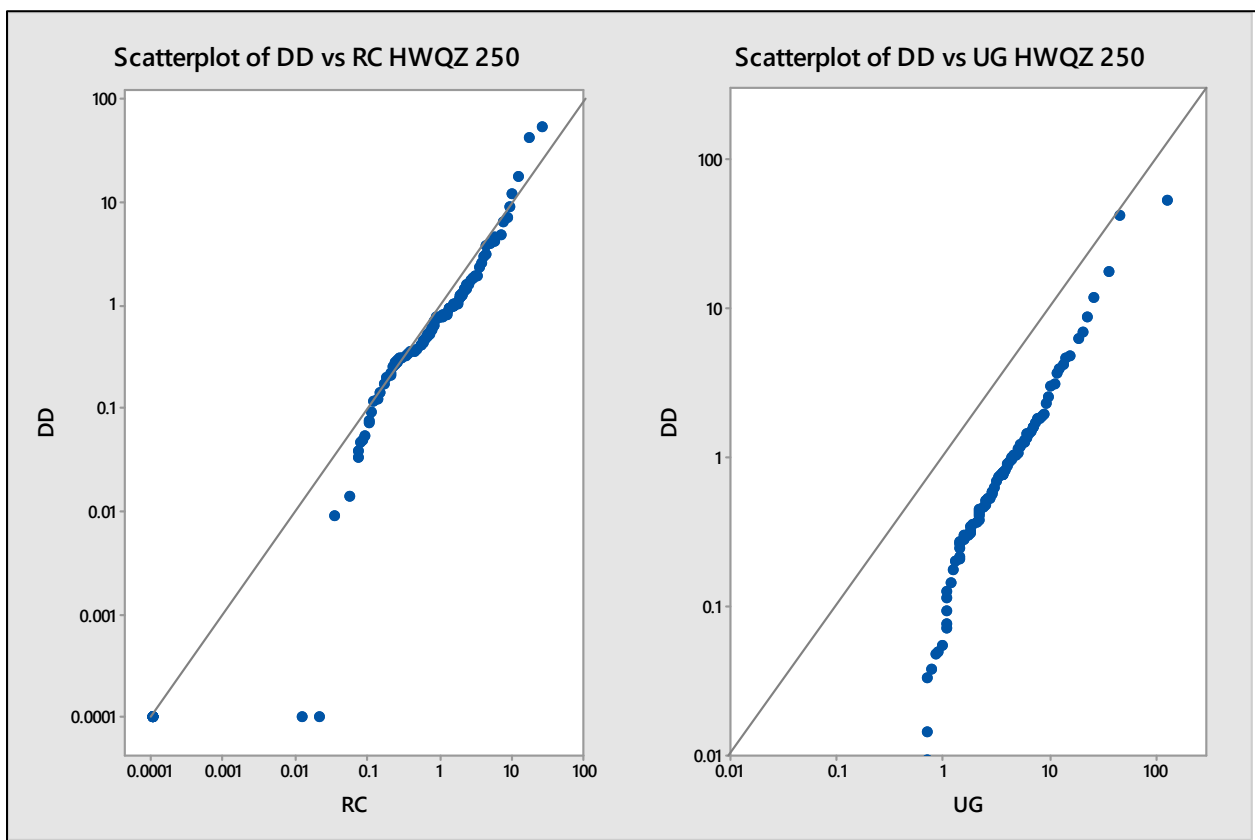

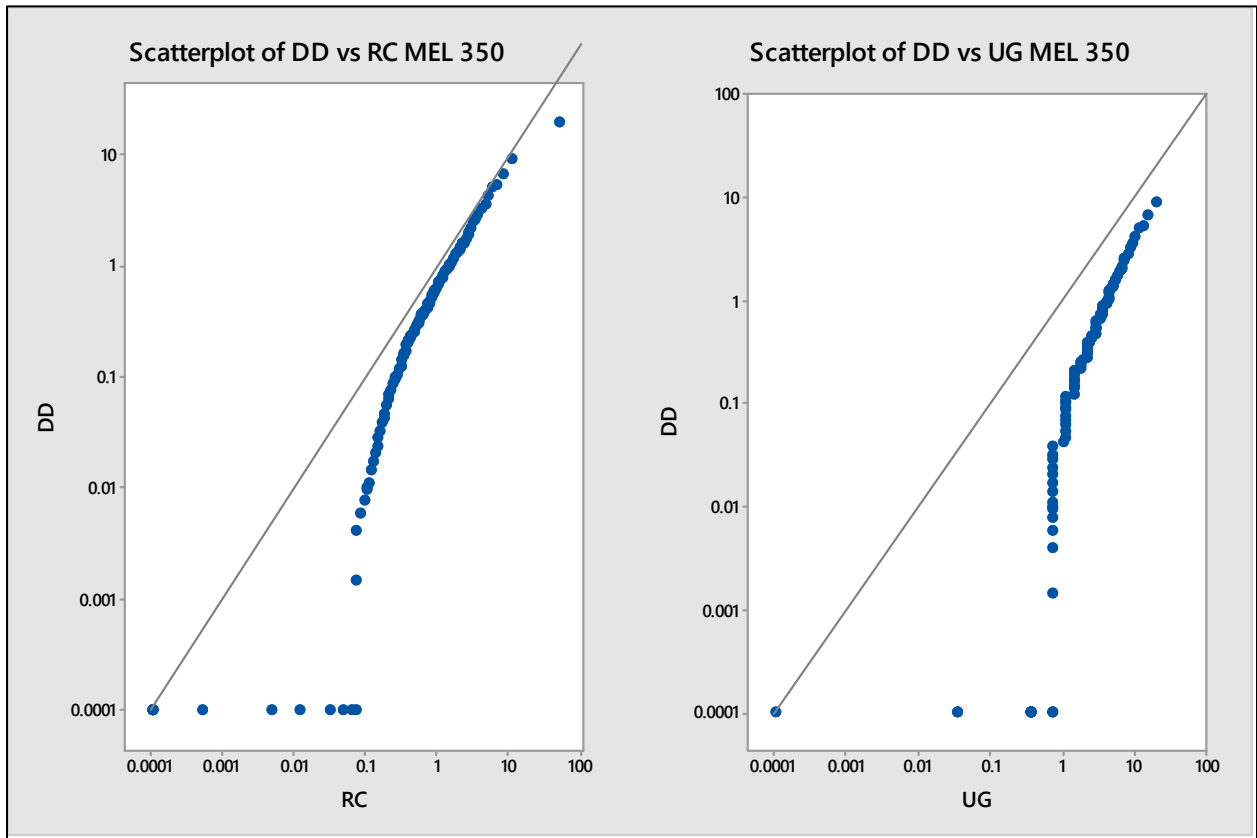
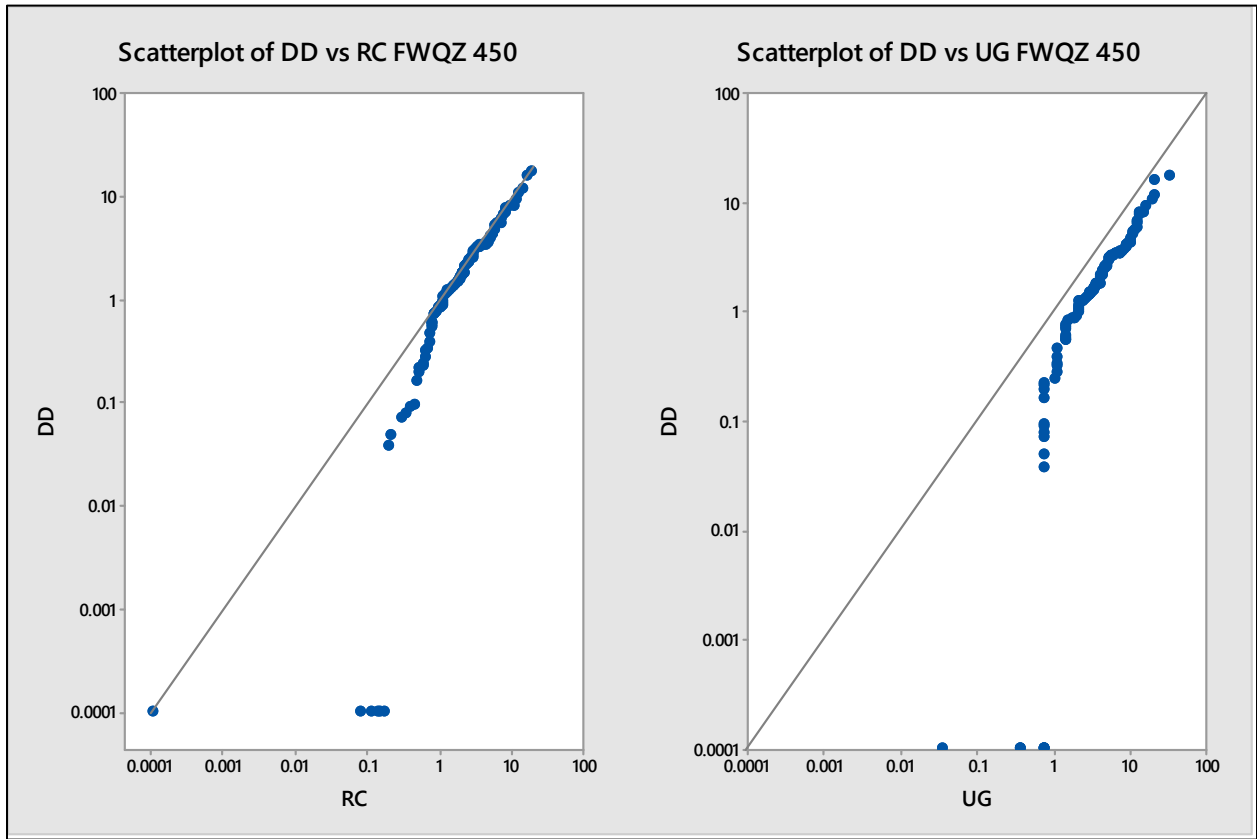

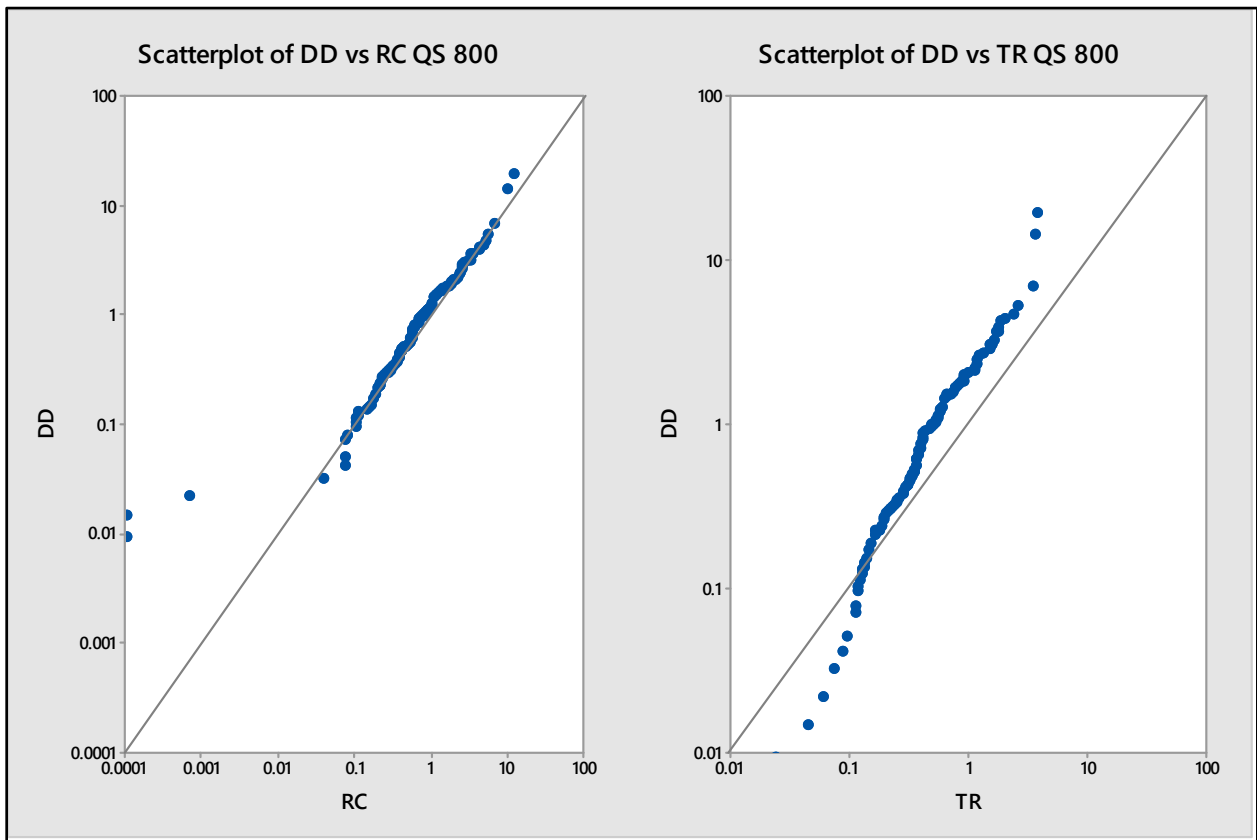
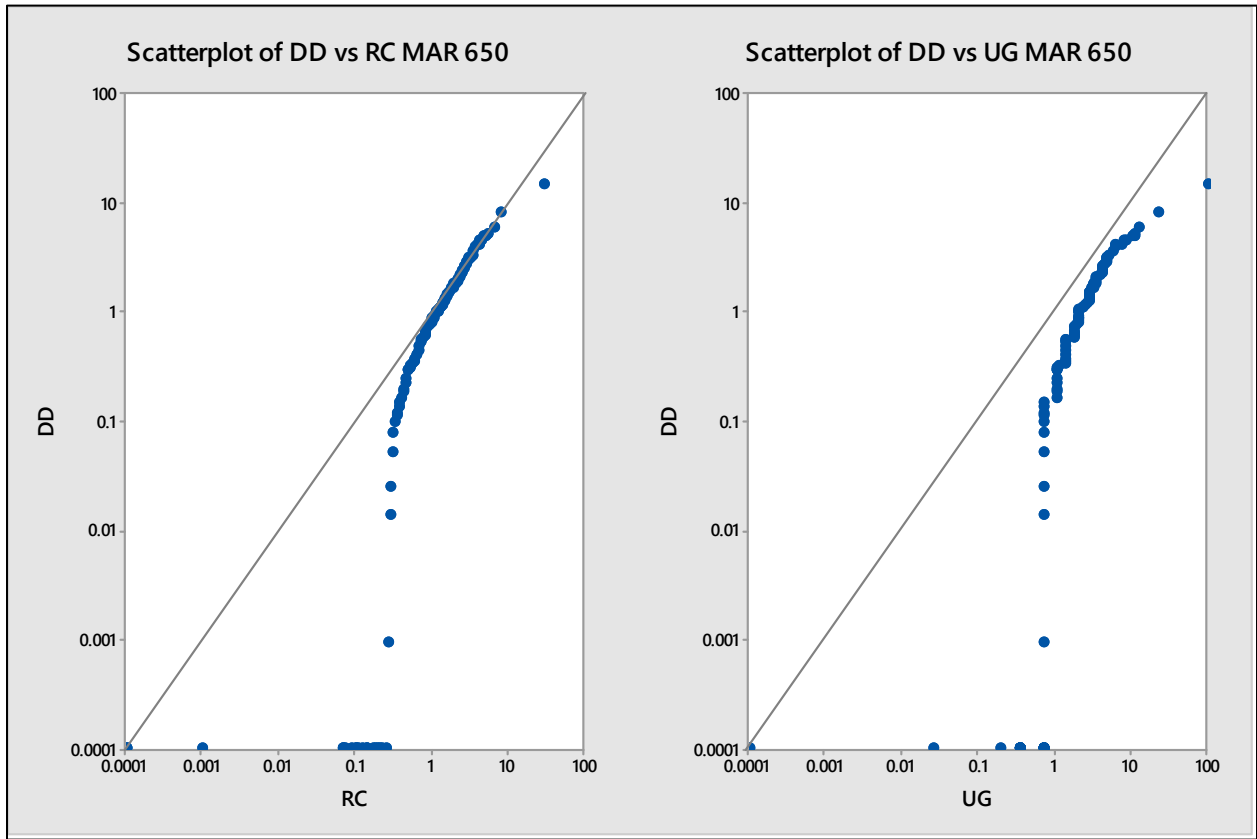

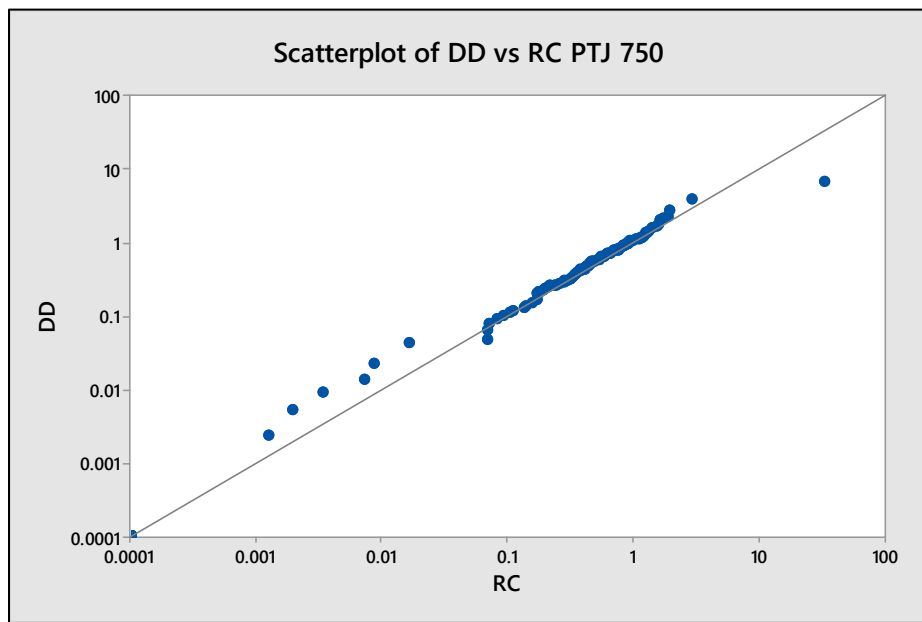

14.10 TREATMENT OF EXTREME VALUES

Capping thresholds were determined by the decomposition of individual composite log-probability distributions. Log-probability plots were generated for each mineralized domain and the resulting graphs are exhibited in Appendix C. Composites were capped to the defined threshold prior to grade estimation (Table 14.6).

TABLE 14.6
COMPOSITE CAPPING THRESHOLDS

Domain	Threshold Au (g/t)	Comp Mean Au (g/t)	Number Capped	Capped Comp Mean Au (g/t)	Change (%)
HWQZ 250	50	4.58	13	4.47	2
MEL 350	17	1.61	28	1.54	4
FWQZ 450	20	3.94	4	3.90	1
MAR 650	12	1.79	13	1.70	5
MAR 655	6	1.03	3	1.02	1
PTJ 750	3	0.64	8	0.57	10
QS 800	7	1.13	6	1.07	5
QS 850	3	1.05	7	0.84	20

14.11 VARIOGRAPHY

Three-dimensional continuity analysis (variography) was conducted on the domain-coded uncapped composite data using a normal-scores transformation. The downhole variogram was viewed at a 1.52 m lag spacing (equivalent to the composite length) to assess the nugget variance

contribution. Standardized spherical models were used to model the experimental semi-variograms in normal-score transformed space. Satisfactory semi-variograms were developed for the HWQZ_250, MEL_350 and MAR_650 domains. Selected variograms are shown in Appendix D.

Semi-variogram model ranges were checked and iteratively refined for each model relative to the overall nugget variance, and the back-transformed variance contributions were then calculated (Table 14.7).

HWQZ_250	Direction 1	Direction 2	Direction 3
Vector	-60 > 65	0 > 335	30 > 65
C0	0.27	0.27	0.27
C1	0.41	0.41	0.41
C2	0.32	0.32	0.32
R1	40	17	10
R2	240	160	20
MEL_350	Direction 1	Direction 2	Direction 3
Vector	-60 > 65	0 > 335	30 > 65
C0	0.08	0.08	0.08
C1	0.63	0.63	0.63
C2	0.29	0.29	0.29
R1	9	8	10
R2	120	95	20
MAR_650	Direction 1	Direction 2	Direction 3
Vector	-55 > 65	0 > 335	35 > 65
C0	0.22	0.22	0.22
C1	0.61	0.61	0.61
C2	0.17	0.17	0.17
R1	10	9	10
R2	110	115	20

14.12 BLOCK MODEL

An orthogonal block model was established across the Project area with the block model limits selected in order to cover the extent of the mineralized domains, and the block size reflecting the narrow vein structures (Table 14.8). The block model consists of separate attributes for estimated grade, rock code, volume percent, bulk density, redox zone and classification attributes. The volume percent block model was used to represent the volume and subsequent tonnage that was contained within the constraining grade domains. Cross-sections and plans showing the block model are presented in Appendix E.

TABLE 14.8 BLOCK MODEL SETUP			
Dimension	Minimum	Number	Size (m)
X	754,000	600	2.5
Y	4,163,400	600	5.0
Z	0	200	5.0
Rotation	30° counter-clockwise		

14.13 GRADE ESTIMATION AND CLASSIFICATION

Block grades for Au were estimated using inverse distance cubed (“ID³”) linear weighting of capped composites. Between four and nine composites from two or more drill holes, trenches or underground channel samples were required for block estimation. Composite samples were selected from within a search ellipse extended to cover the extents of the modelled domain and rotated parallel to the modelled domain. Ordinary Kriging (“OK”) and Nearest Neighbor models were also estimated for validation purposes using the same grade estimation strategy.

Blocks within 55 m of a drill hole and at least two additional drill holes, trenches or underground channel samples were classified as Indicated, based on approximately 50% of the semi-variogram ranges developed for the Melange and Mariposa domains. Indicated Mineral Resources were also restricted to the Pine Tree-Josephine area. All estimated grade blocks outside this range within the Mineral Resource Estimate wireframes were classified as Inferred.

Selected classification block cross-sections and plans are presented in Appendix F.

The Authors are satisfied that the current level of information available is sufficient to classify the Mineral Resource as Indicated and Inferred Mineral Resources. Mineral Resources were classified in accordance with definitions established by the Canadian Institute of Mining, Metallurgy and Petroleum (2014) and Best Practices Guidelines (2019):

A Measured Mineral Resource is that part of a Mineral Resource for which quantity, grade or quality, densities, shape, and physical characteristics are estimated with confidence sufficient to allow the application of Modifying Factors to support detailed mine planning and final evaluation of the economic viability of the deposit. Geological evidence is derived from detailed and reliable exploration, sampling and testing and is sufficient to confirm geological and grade or quality continuity between points of observation. A Measured Mineral Resource has a higher level of confidence than that applying to either an Indicated Mineral Resource or an Inferred Mineral Resource. It may be converted to a Proven Mineral Reserve or to a Probable Mineral Reserve.

An Indicated Mineral Resource is that part of a Mineral Resource for which quantity, grade or quality, densities, shape and physical characteristics are estimated with sufficient confidence to allow the application of Modifying Factors

in sufficient detail to support mine planning and evaluation of the economic viability of the deposit. Geological evidence is derived from adequately detailed and reliable exploration, sampling and testing and is sufficient to assume geological and grade or quality continuity between points of observation. An Indicated Mineral Resource has a lower level of confidence than that applying to a Measured Mineral Resource and may only be converted to a Probable Mineral Reserve.

An Inferred Mineral Resource is that part of a Mineral Resource for which quantity and grade or quality are estimated on the basis of limited geological evidence and sampling. Geological evidence is sufficient to imply but not verify geological and grade or quality continuity. An Inferred Mineral Resource has a lower level of confidence than that applying to an Indicated Mineral Resource and must not be converted to a Mineral Reserve. It is reasonably expected that the majority of Inferred Mineral Resources could be upgraded to Indicated Mineral Resources with continued exploration.

Measured Mineral Resources are lacking because the underground sampling at Pine Tree-Josephine does not meet the requirements for inclusion in a Measured Mineral Resource for the following reasons:

- The data are digitized from historical sample plans dating back to the 1930s;
- Original assay certificates are not available;
- Grades are in ounces per short ton (“oz/ton”) with only two significant digits. An oz/ton grade of 0.01 could represent a grade in grams of anywhere between 0.17 and 0.48 g/t Au;
- Information on survey methods is not available;
- Information on the conversion from mine grid to UTM is not available; and
- Lack of recent reliable metallurgical test work.

14.14 MINERAL RESOURCE ESTIMATE

National Instrument 43-101 incorporates by reference the definition of, among other terms, Mineral Resource from the Canadian Institute of Mining, Metallurgy and Petroleum Definition Standards for Mineral Resources & Mineral Reserves (the “CIM Definition Standards (2014)” and Best Practices Guidelines (2019)). Under the CIM Definition Standards, a Mineral Resource must have “reasonable prospects for eventual economic extraction”. In order to meet this criterion, the Authors generated constraining conceptual pit shells and calculated separate cut-offs for the oxide and sulphide zones (Figure 14.8). The results from the constraining pit shell are used solely for the purpose of reporting Mineral Resources and include Indicated and Inferred Mineral Resources. Optimized pit shells are presented in Appendix G.

Out-of-Pit Mineral Resources have been constrained to potentially minable longhole stope shapes, based on block grade and continuity.

Historical mining has been depleted from the Mineral Resource Estimate by assigning a zero-volume percentage block inclusion for known areas of mining and development.

Pit-constrained Mineral Resources are reported using a cut-off grade of 0.25 g/t Au for oxide material, and 0.45 g/t Au for sulphide material (Table 14.9). Out-of-Pit Mineral Resources are reported using a cut-off grade of 1.45 g/t Au.

The effective date of this Mineral Resource Estimate is February 15, 2023.

FIGURE 14.8 MINERAL RESOURCES AND PIT LIMITS

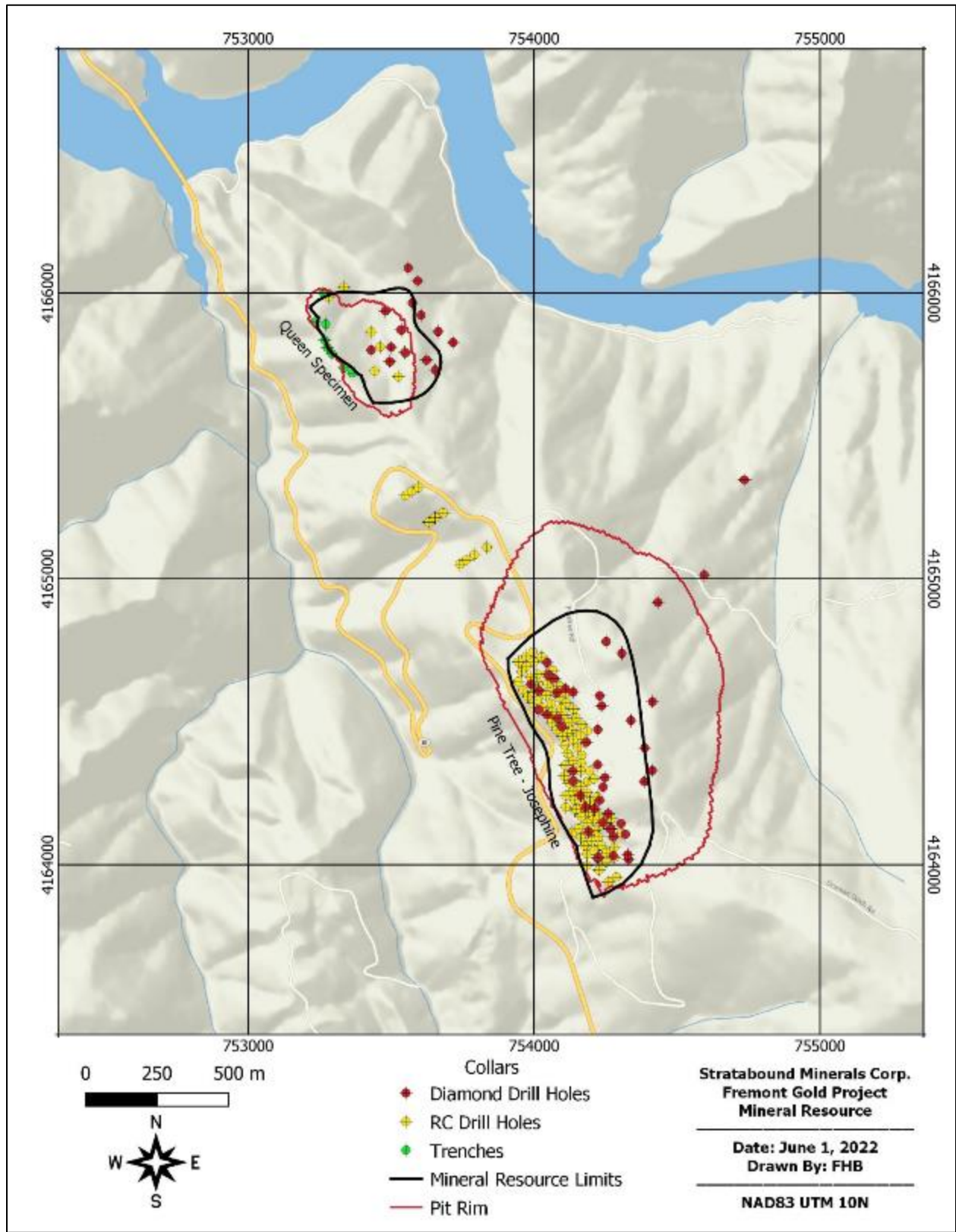

TABLE 14.9
SUMMARY OF MINERAL RESOURCE ESTIMATE (1-12)

Mineral Resource	Group	Cut-off Au (g/t)	Tonnes (k)	Au (g/t)	Au (koz)
Pit- Constrained	Indicated Oxide	0.25	511	0.91	15
	Inferred Oxide	0.25	30	0.65	1
	Indicated Sulphide	0.45	12,791	1.57	646
	Inferred Sulphide	0.45	20,685	1.96	1,300
	Indicated Quartz	0.25	5,589	2.75	493
	Inferred Quartz	0.25	1,792	3.25	187
	Total Indicated	--	18,891	1.90	1,154
	Total Inferred	--	22,507	2.06	1,488
Out-of-Pit	Indicated Oxide	1.45	0	0.00	0
	Inferred Oxide	1.45	0	0.00	0
	Indicated Sulphide	1.45	82	2.12	6
	Inferred Sulphide	1.45	5,529	2.74	487
	Indicated Quartz	1.45	39	2.41	3
	Inferred Quartz	1.45	287	5.382	49.7
	Total Indicated	--	121	2.21	9
	Total Inferred	--	5,816	2.87	536
Total	Indicated Oxide	--	511	0.91	15
	Inferred Oxide	--	30	0.65	1
	Indicated Sulphide	--	12,873	1.57	652
	Inferred Sulphide	--	26,214	2.12	1,787
	Indicated Quartz	--	5,627	2.74	496
	Inferred Quartz	--	2,079	3.54	237
	Total Indicated	--	19,011	1.90	1,163
	Total Inferred	--	28,323	2.22	2,024

Notes:

- 1) Mineral Resources were estimated using the Canadian Institute of Mining, Metallurgy and Petroleum ("CIM"), CIM Standards on Mineral Resources and Reserves, Definitions (2014) and Best Practices (2019) prepared by the CIM Standing Committee on Reserve Definitions and adopted by CIM Council.
- 2) The Inferred Mineral Resource in this estimate has a lower level of confidence that that applied to an Indicated Mineral Resource and must not be converted to a Mineral Reserve. It is reasonably expected that the majority of the Inferred Mineral Resource could be upgraded to an Indicated Mineral Resource with continued exploration.
- 3) Mineral Resources are reported within a constraining conceptual pit shell.
- 4) Inverse distance weighting of capped composite grades within domains was used for grade estimation.
- 5) Composite grade capping was implemented prior to grade estimation.
- 6) Bulk density was assigned by domain.
- 7) A gold price of US\$1,700/oz was used.

- 8) A cut-off grade of 0.25 g/t Au for oxide and quartz pit-constrained material, 0.45 g/t Au for sulphide pit-constrained material, and 1.45 g/t Au for out-of-pit material was used.
- 9) Pit-constrained Mineral Resources were determined to be potentially extractable based on a mining cost of \$3/t mined, heap leach processing of \$9.16/t, flotation processing of \$10.02/t and G&A costs of \$2.50/t, with metallurgical recoveries of 85% by heap leach and 90% by flotation.
- 10) Out-of-Pit Mineral Resources were determined to be potentially extractable with the longhole mining method based on an underground mining cost of \$40/t mined, processing of \$10.02/t and G&A costs of \$2.50/t, with a metallurgical recovery of 90%. Out-of-Pit grade blocks that did not demonstrate potentially mineable configurations were removed from the Mineral Resource Estimate.
- 11) Totals may not sum due to rounding.
- 12) Mineral Resources that are not Mineral Reserves do not have demonstrated economic viability.

14.15 GRADE SENSITIVITY

The sensitivity of the pit-constrained Mineral Resource Estimate to changes in cut-off grade was examined by summarizing tonnes, grade and metal content within the Mineral Resource pit shell at varying cut-off grades for Indicated and Inferred Mineral Resources (Tables 14.10 and 14.11). The results suggest that the Mineral Resource model is relatively insensitive to changes in cut-off grade due to the high average Au grade compared to the cut-off grade.

Mineral Resource	Cut-off Au (g/t)	Tonnes (k)	Au (g/t)	Au (koz)
Indicated Oxide	1.00	140	1.85	8
	0.90	161	1.74	9
	0.80	192	1.60	10
	0.70	229	1.46	11
	0.60	282	1.30	12
	0.50	337	1.18	13
	0.40	399	1.07	14
	0.30	474	0.96	15
	0.25	511	0.91	15
	0.20	546	0.86	15
Inferred Oxide	1.00	4	1.38	0
	0.90	5	1.30	0
	0.80	6	1.23	0
	0.70	7	1.16	0
	0.60	16	0.86	0
	0.50	19	0.81	1
	0.40	24	0.73	1
	0.30	29	0.67	1
	0.25	30	0.65	1
	0.20	31	0.64	1

TABLE 14.11				
SULPHIDE MINERAL RESOURCE ESTIMATE SENSITIVITY				
Mineral Resource	Cut-off Au (g/t)	Tonnes (kt)	Au (g/t)	Au (koz)
Indicated Sulphide	1.00	7,485	2.19	527
	0.90	8,237	2.08	550
	0.80	9,083	1.96	573
	0.70	10,007	1.85	595
	0.60	11,024	1.74	616
	0.50	12,170	1.63	636
	0.45	12,791	1.57	646
	0.40	13,412	1.52	654
Inferred Sulphide	1.00	16,052	2.31	1,194
	0.90	16,779	2.26	1,216
	0.80	17,672	2.18	1,241
	0.70	18,447	2.12	1,260
	0.60	19,265	2.06	1,277
	0.50	20,202	1.99	1,293
	0.45	20,685	1.96	1,300
	0.40	21,139	1.92	1,307

14.16 VALIDATION

The block model was validated visually by the inspection of successive cross-sections, in order to confirm that the model correctly reflects the distribution of high-grade and low-grade samples. Block model cross-sections are presented in Appendix E.

The total modelled volume of 32.0 million cubic metres was compared to the total estimated volume of 29.1 million cubic metres. The 10% difference in volumes is attributed to the cross-cutting quartz veins.

As a further check on the model, the average ID³ model block grade was compared to the Ordinary Kriging block model, the Nearest Neighbour block model, and to the capped composite data. The comparison indicates that the HWQZ_250 domain is sensitive to scattered high-grade samples. The Authors note that differences with the OK averages are potentially a result of the poor variograms for domains other than HWQZ_250, MEL_350 and MAR_650, and for this reason OK was not selected for the Mineral Resource Estimate. No other significant bias between the block model and the input data was noted (Table 14.12).

**TABLE 14.12
GRADE BLOCK MODEL CHECK**

Domain	ID³ Average Au (g/t)	OK Average Au (g/t)	NN Average Au (g/t)	Composite Average Au (g/t)
HWQZ 250	2.22	2.22	2.07	4.47
MEL 350	1.34	1.39	1.51	1.54
FWQZ 450	3.30	3.26	3.16	3.90
MAR 650	1.41	1.45	1.36	1.70
MAR 655	1.06	0.58	0.56	1.02
PTJ 750	0.58	1.17	1.09	0.57
QS 800	1.19	0.77	0.91	1.07
QS 850	0.80	0.99	0.93	0.84
Total	1.43	1.46	1.47	2.23

Note: ID³ = inverse distance cubed, OK = ordinary kriging, NN = Nearest Neighbour.

A check for local bias was also carried out by generating a swath plot to examine spatial smoothing along the Queen Specimen and Pine Tree-Josephine Deposits. The swath plot indicates that there has not been any undue smearing of the grades spatially throughout the Deposit (Figure 14.9).

FIGURE 14.9 SWATH PLOT

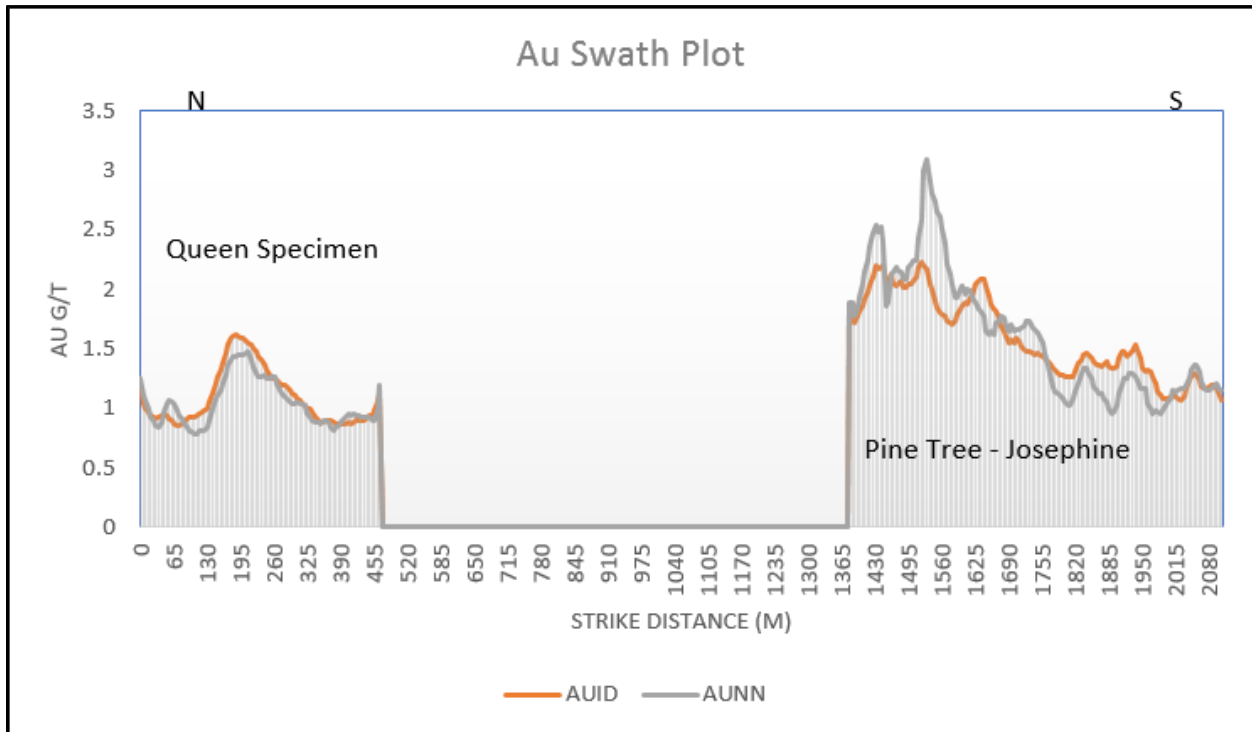

A Mineral Resource Estimate (“MRE”) for the Pine Tree-Josephine Deposit dated September 30, 2021 was prepared by SLR Consulting, Toronto². This (current) Technical Report and updated Mineral Resource Estimate supersedes all previous Technical Reports and Mineral Resource Estimates for the Fremont Project.

Substantial differences in the methodology used for this updated MRE include the following:

- The incorporation of underground channel sampling in the Pine Tree-Josephine model;
- Extending current MRE to 600 m below surface versus 350 m in previous MRE
- The use of lower cut-off grades;
- The incorporation of oxide and sulphide zones;
- The development of a refined mineralization model respecting both lithological and metallurgical domains;
- Incorporation of the Queen Specimen Deposit; and
- Capping of composites versus capping of assays.

² Ciuculescu, T (2021). *Technical Report on the Fremont Gold Project, Central California, USA*. Technical report prepared by SLR Consulting for Stratabound Minerals Corp. with an effective date of August 31, 2021.

15.0 MINERAL RESERVE ESTIMATES

There is no Mineral Reserve Estimate stated for the Fremont Gold Project. This section is not applicable to this Technical Report.

16.0 MINING METHODS

The Fremont Gold Project will consist of both open pit and underground mining operations. A year of open pit pre-production is planned, followed by seven years of production. Underground mining development will commence in the second year of open pit production. Both methods will operate simultaneously for six years. The entire duration of mining activity will be 11 years.

Open pit mining is described in Section 16.1 and underground mining is discussed in Section 16.2. The combined open pit and underground production schedule and processing schedule are described in Section 16.3.

16.1 OPEN PIT MINING

The Fremont Gold Property contains several gold systems, some of which were partially mined in the past. The deposits are near surface and lend themselves to conventional open pit mining methods. For this PEA production plan, two different open pits will be developed over the life of the Project to support the processing operation; the Pine Tree/Josephine Pit and the Queen Specimen Pit.

The topography across the Project site is quite hilly and mining will occur in pits located along various hillsides.

The excavation of the open pits will require the removal of three different materials, all of which are tracked separately in the production schedule:

- **Waste Rock:** is barren or low-grade material, also placed into nearby waste rock storage facilities or used for haul road construction.
- **Process Plant Feed:** is mineralized sulphide rock above cut-off grade that will be hauled to the process (flotation) plant facility.
- **Oxide Feed:** is gold-bearing material amenable to be heap leached in the first year of production.

The design of the open pit layouts and the mining schedule requires several steps. These are:

- Run pit optimizations to select the optimal pit shells to be used for mine design.
- Design an operational pit (with ramps and benches) based on the optimal pit shell.
- Design pit phases as needed to moderate the mining sequence.
- Develop a life-of-mine mine production schedule, based on supplying 6,000 tpd (2.19 Mtpa) of mineralized feed to the process plant.

16.1.1 Open Pit Optimizations

A series of pit optimizations were completed on the Mineral Resource block model using the Datamine NPV Scheduler™ software package. This optimization process produces a series of nested pit shells each containing mineralized material that is potentially economically mineable according to a given set of physical and economic parameters.

A combined pit optimization was run for both the Pine Tree-Josephine Pit and Queen Specimen Pit. However, different optimization shells were selected for each pit since underground mining would occur beneath the Pine Tree-Josephine Pit. Hence, mineralized material not mined in the Pine Tree-Josephine open pit could be recovered in the underground mine.

The pit optimizations were run using the parameters shown in Table 16.1. It is assumed that waste rock materials would be hauled one km to a nearby waste rock storage facility near each pit. In California, permitting requires that mined open pits be backfilled. Hence the waste mining cost was increased in the pit optimizations to \$3.40/t to accommodate a cost to double-handle (i.e., backfill) most of the waste rock.

Four mineralization types were examined with different operating costs and process recoveries. Three types consisted of sulphide material suitable for flotation processing (Type No. 15, 20, 30). This material is refractory and hence it is assumed the gold concentrate would be further processed off-site and this cost and recovery is incorporated into the gold recovery values.

For pit optimization, a base case gold price of \$US1,700/oz was used. The optimization analysis included Indicated and Inferred Mineral Resources. Revenue factors ranging from 6 to 120% were applied in the optimization, with the base case gold price being the 100% revenue factor.

TABLE 16.1
PIT OPTIMIZATION PARAMETERS

Items	Unit	Mineralization Type		
		Oxide (Heap Leach)	Quartz Hosted (FT + Roasting)	Sulphide (FT + Roasting)
		Rock Code 10	Rock Code 30	Rock Codes 15 & 20
Mineral Resource Classes to use		Inf & Ind	Inf & Ind	Inf & Ind
Processing Method		Heap Leach	Flotation	Flotation
Throughput Rate	tpy	500,000	2,900,000	2,900,000
Gold Price Base	US\$/oz	1,700	1,700	1,700
(-) Refining Cost	US\$/oz	5.00	5.00	5.00
(-) Payable %	%	99.0	99.0	99.0
(-) NSR Royalty	%	3	3	3
(=) Net Gold Price	US\$/oz	1,628	1,628	1,628

**TABLE 16.1
PIT OPTIMIZATION PARAMETERS**

Items	Unit	Mineralization Type		
		Oxide (Heap Leach)	Quartz Hosted (FT + Roasting)	Sulphide (FT + Roasting)
		Rock Code 10	Rock Code 30	Rock Codes 15 & 20
Operating Costs				
Waste Mining & Haul Cost	\$/t	3.40	3.40	3.40
Ore Mining & Haul Cost	\$/t	2.50	2.50	2.50
Processing (Heap Leaching)	\$/t	9.16	n/a	n/a
Processing (Flotation)	\$/t	n/a	10.41	10.41
Concentrate Ship+Roast+Leach	\$/t	n/a	7.77	7.77
G&A	\$/t	6.00	1.72	1.72
Total Opex (for COG)	\$/t	15.16	19.90	19.90
Process Recovery				
Gold recovery	%	85	82	75
Cut-off Grades				
Incremental Operating Cost	\$/t	15.16	19.90	19.90
Cut-off Grade (AuEq)	g/t	0.34	0.46	0.51
Pit Slopes (includes -5 deg for road allowance)				
	FW 150-330° (west side)	40 deg	40 deg	40 deg
	HW 330-150° (east side)	40 deg	49 deg	49 deg
Overburden				
	0-360°	34 deg	34 deg	34 deg

Notes: FT = flotation, FW = footwall, HW = hanging wall, M & I & I = Mineral Resource Classifications of Measured & Indicated & Inferred, COG = cut-off grade.

The results of pit optimization are shown in Figure 16.1. The Net Present Value (“NPV”) curve flattens off above a revenue factor of 82%.

For the Pine Tree-Josephine Pit, underground mining would occur below the pit, recovering mineralized material not mined in the pit. Hence the open pit size was selected to reduce waste mining volumes and backfilling volumes. The Pit 22 (48%) shell was selected as the design basis for the Pine Tree-Josephine Pit.

For the Queen Specimen Pit, underground mining would not take place due to the lower head grades there. Hence the open pit size was maximized to increase the tonnage of mineralized material recovered in the open pit. The Pit 38 (80%) shell was selected as the design basis for the Queen Specimen Pit.

FIGURE 16.1 PIT OPTIMIZATION RESULT: NPV VERSUS REVENUE FACTOR

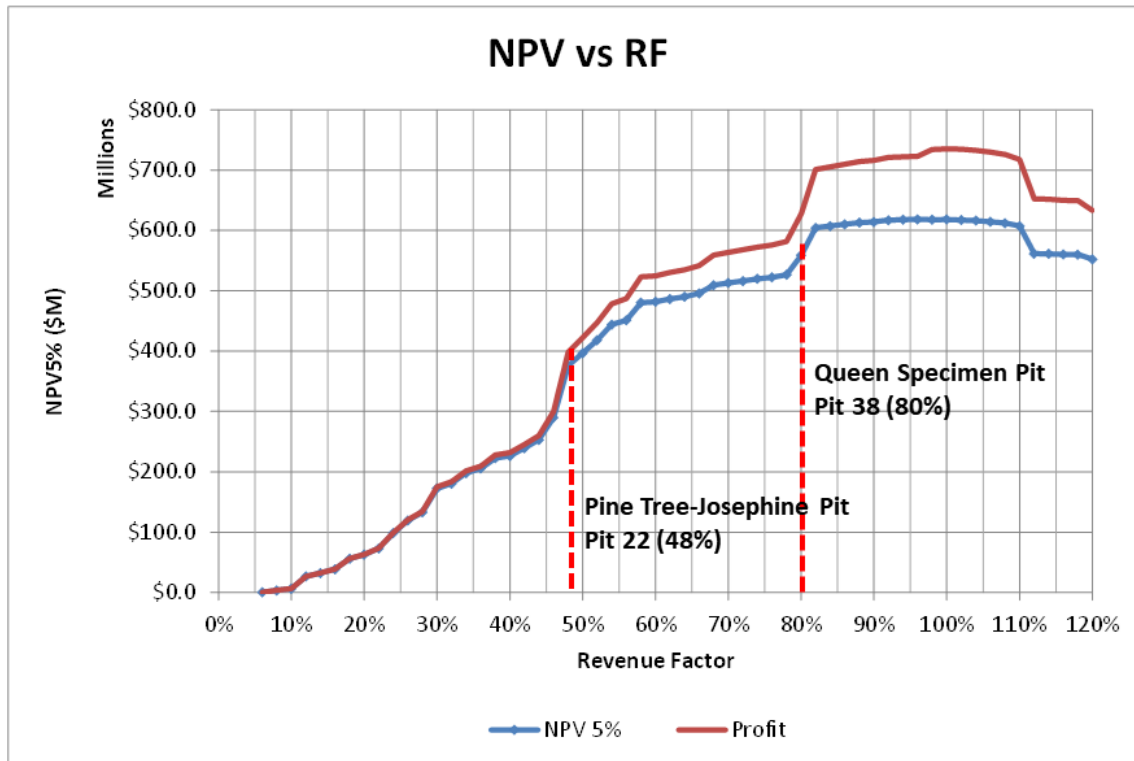

16.1.2 Pit Designs

The pit designs were developed using the optimized shell as a guide.

Engineering of the pit design examined preferred access points along the pit periphery, and then added benches, ramps and haul roads according to the parameters shown in Table 16.2. Single lane haul roads and ramps were used in the bottom benches of several of the pits to minimize the amount of waste rock mined.

**TABLE 16.2
PIT DESIGN PARAMETERS**

Parameter	Unit	FW (West Side) Az 150 to 330°	HW (East Side) Az 330 to 150°
Bench Height	m	5.0	5.0
Number of Benches		4	4
Berm Interval Height	m	20.0	20.0
Inter-ramp Angle	degrees	45	54
Bench Face Angle	degrees	65	75
Berm Width	m	10.7	9.2
Haul Road Widths		Double Lane	Single Lane
10% max gradient	m	30	18

Note: FW = footwall, HW = hanging wall.

The Pine Tree-Josephine Pit design is shown in Figure 16.2 and the Queen Specimen Pit is shown in Figure 16.3.

FIGURE 16.2 PINE TREE-JOSEPHINE PIT DESIGN

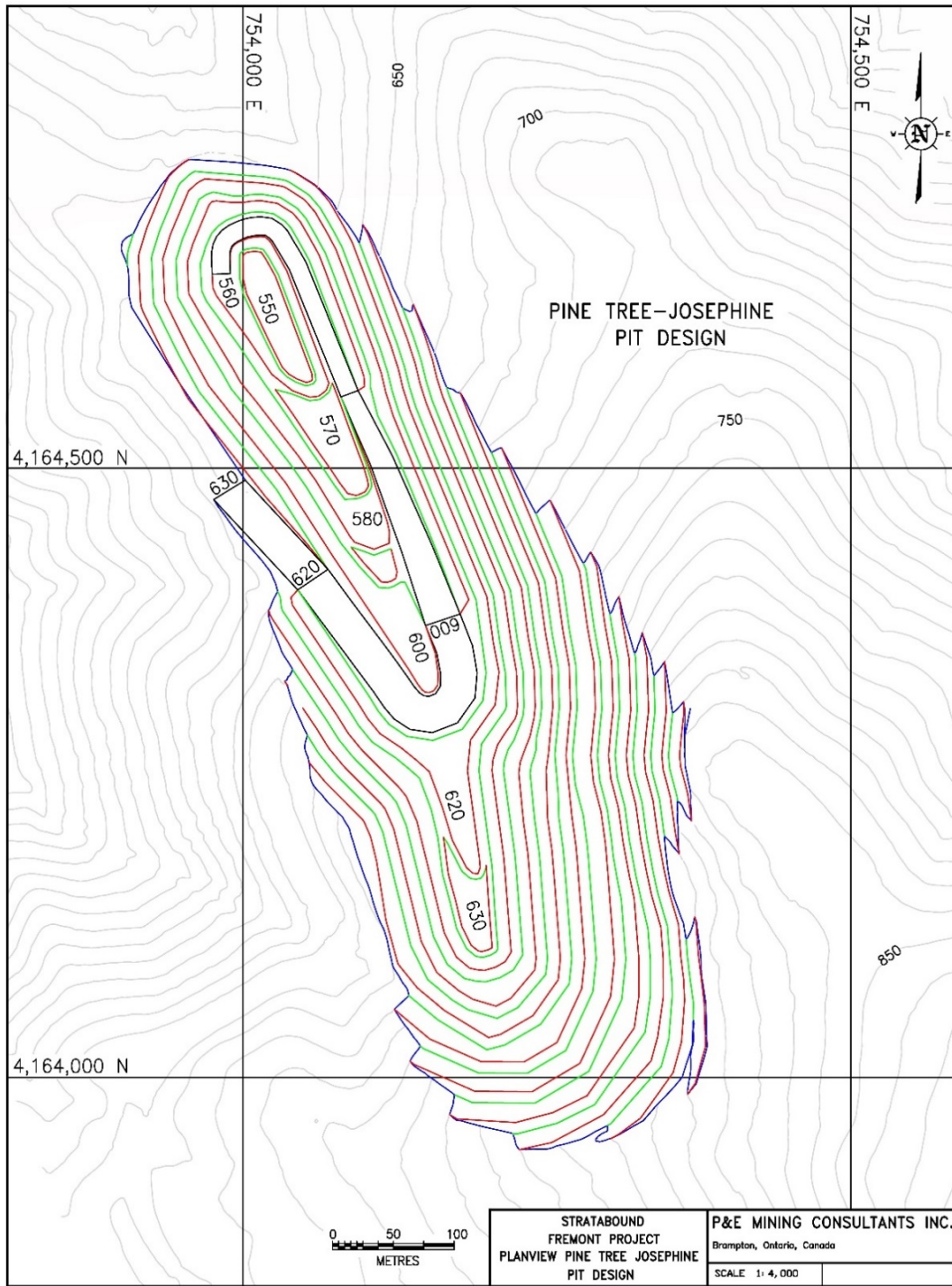
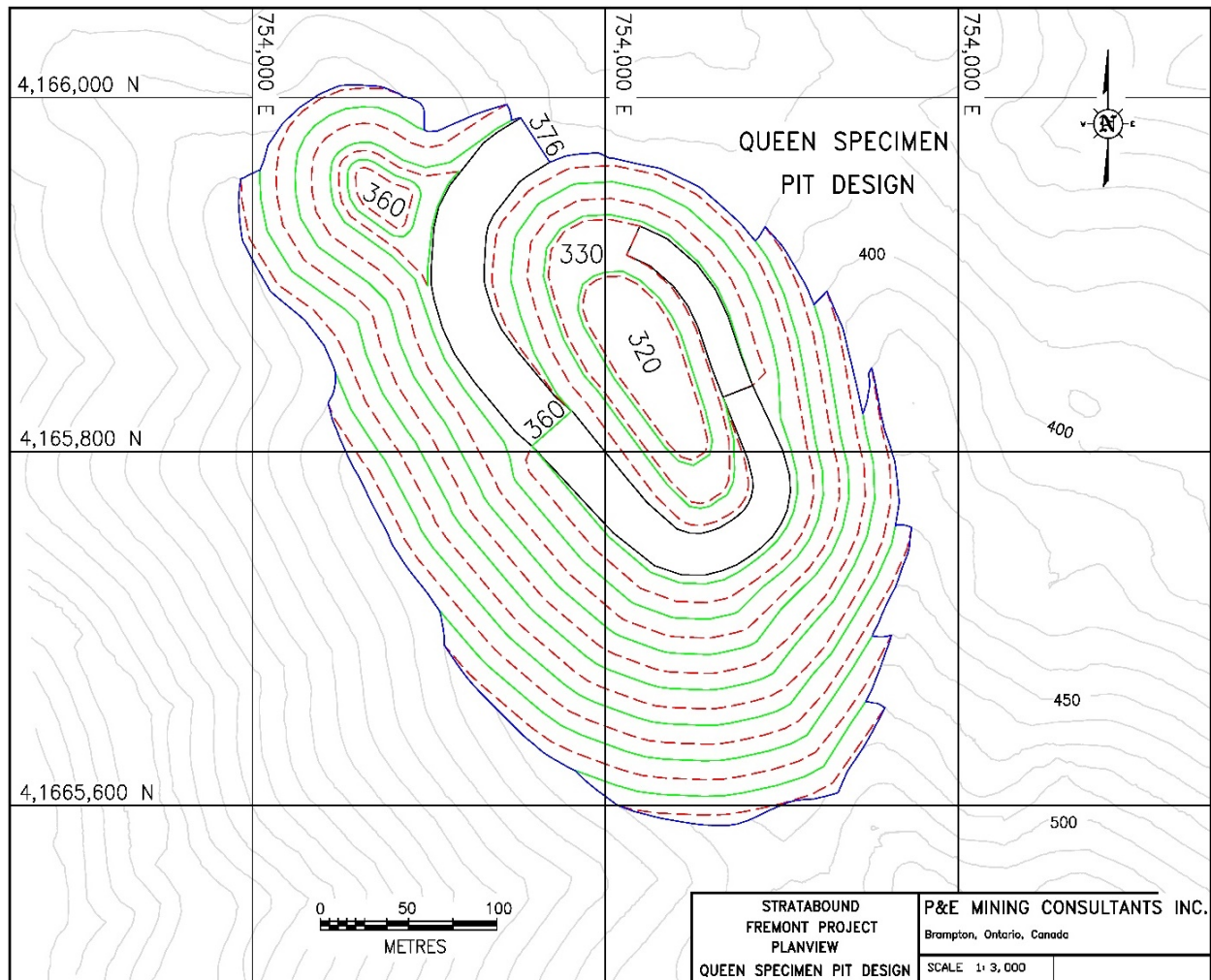

FIGURE 16.3 QUEEN SPECIMEN PIT DESIGN



16.1.2.1 Geotechnical Studies

A pit slope geotechnical study was completed by Golder Associates in 1988 for a previous operator of the Project. The resulting report is dated July 1988 and titled “Compilation of Geotechnical Reports Prepared by Golder Associates for Goldenbell Resources Incorporated, Re Pine Tree Project, Mariposa County California”. The design pit slopes used for this PEA are based on this report and are summarized in Table 16.2.

16.1.2.2 Hydrogeological Studies

No hydrogeological studies have been completed for the PEA to assess groundwater conditions. It is assumed that most of the open pits will be relatively dry. Underground mining may likely encounter groundwater.

16.1.2.3 Mining Dilution and Losses

During mining, dilution and losses will occur. It is assumed that low-grade rock surrounding the mineralized zones would be mixed with the planned mineralized material during mining, thereby causing dilution. Historical underground workings may be purposely collapsed as open pit mining approaches the workings, which may result in additional dilution.

In order to estimate the amount of dilution, a 2 m thick waste “skin” is assumed around the outside perimeter of the mineralized zones and this was modelled on the pit benches. The volume of this skin relative to the volume of the mineralized zone subsequently determines the amount of dilution. When the waste “skin” is averaged over several benches in the open pit the overall average dilution is 13.7%.

A 3-D solid was created for the diluting “skin” outside the mineralized zone and the diluting grade was estimated from skin-constrained assays. The diluting grade applied is 0.50 g/t Au.

Mineralized mined material losses incurred during mining are assumed at 3% for both open pits.

As an example, Table 16.3 presents the impact that dilution and mining losses have on the tonnage within the Pine Tree-Josephine Pit. The waste quantity decreases as waste gets mixed in with the mineralized material.

Item	Unit	Undiluted	Diluted
Total Pit Material	Mt	32.25	32.25
Total Waste Material	Mt	24.25	23.93
Strip Ratio	W:O	3.0	2.9
Total Mineralized Material (all feeds)	Mt	8.00	8.83
Total Mineralized Material to Process Plant	Mt	7.54	8.31
Au grade	g/t	1.97	1.80
Oxide Mineralized Material to Heap Leach	Mt	0.46	0.51
Au grade	g/t	0.99	0.93

After the two pit designs are completed, the dilution and mining loss factors are applied to the tonnage contained within. The potential mineralized material and waste rock tonnages are reported inside each pit. These are summarized in Table 16.4. These diluted tonnages are used as the planning basis for the PEA open pit production schedule. The breakdown by Mineral Resource classification is shown in Table 16.5.

TABLE 16.4				
TOTAL PIT TONNAGES (DILUTED)				
Item	Unit	Pine Tree-Josephine Pit	Queen Specimen Pit	Total
Total Open Pit Material	Mt	32.25	12.82	45.07
Total Waste Material	Mt	23.93	10.68	34.61
Strip Ratio	W:O	2.9	5.0	3.3
Total Mineralization (all feeds)	Mt	8.83	2.14	10.97
Total Mineralized Material to Process Plant	Mt	8.31	2.14	10.45
Au grade	g/t	1.80	1.31	1.70
Oxide Mineralized Material to Heap Leach	Mt	0.51		0.51
Au grade	g/t	0.93		0.93
Contained Gold to Processing	oz	479,836	90,128	569,964

TABLE 16.5						
MINERALIZED MATERIAL PLANT FEED CLASSIFICATION						
Classification	Pine Tree-Josephine Pit (Mt)	Au (g/t)	Queen Specimen Pit (Mt)	Au (g/t)	Total (Mt)	Au (g/t)
Sulphide to Process Plant						
Indicated	7.91	1.82			7.91	1.82
Inferred	0.41	1.33	2.14	1.31	2.55	1.31
Total	8.31	1.80	2.14	1.31	10.45	1.70
Oxide to Heap Leach						
Indicated	0.50	0.94			0.50	0.94
Inferred	0.01	0.72			0.01	0.72
Total	0.51	0.93			0.51	0.93

16.1.3 Open Pit Mining Schedule

The open pit mine production schedule consists of one year of pre-production pre-stripping and seven years of mine production.

The target processing rate is approximately 2.19 Mt per year, or 6,000 tpd. Table 16.6 presents the open pit mine production schedule.

To improve the head grade to the process plant, lower-grade mineralization between the Au cut-off grades of 0.46 g/t and 0.90 g/t was stockpiled for later processing in the LOM production schedule. The peak size of this low-grade stockpile is 1.4 Mt at an average grade of 0.67 g/t Au.

Note: the potential process plant mineralized material tonnages utilized in the PEA contain both Indicated and Inferred Mineral Resources. The reader is cautioned that Inferred Mineral Resources are considered too speculative geologically to have the economic considerations applied to them that would enable them to be categorized as Mineral Reserves, and there is no certainty that value from such Mineral Resources will be realized either in whole or in part.

16.1.4 Open Pit Mining Practices

It is assumed that the Fremont Gold mine will be an owner-operated conventional open pit mining operation. While contract mining may be a viable option, it was not examined in this PEA.

The mine operation will undertake all drilling and blasting, loading, hauling, and mine site maintenance activities. In addition, the operation will require technical services, such as mine planning, grade control, geotechnical, and surveying.

It is anticipated that the mining operations would be conducted 24 hours per day and 7 days per week throughout the entire year.

It is assumed that all materials mined will require drilling and blasting to some degree. Open pit bench heights are planned at 5 m and ammonium nitrate/fuel oil mixture (“ANFO”) explosives are planned for use.

It is expected that diesel powered front-end loaders (CAT 992 size) and hydraulic excavators will be used to dig the blasted rock. The anticipated truck size is 90 t, similar to the CAT 777, although alternate truck sizes may be used depending on future pit configuration and haulage distances.

The primary mining operation will be supported by a fleet of support equipment consisting of dozers, road graders, watering trucks, maintenance vehicles, and service vehicles.

Portions of the deeper pits will likely experience groundwater seepage. No quantitative information was available to adequately predict the expected water inflow into the pits. There is the potential that some of the pit water could be pumped to the process plant to be used as a source of process water. There is also potential that water may drain into historical workings.

The open pit equipment fleet by year is summarized in Table 16.7 and the associated manpower is shown in Table 16.8. Some equipment and personnel are required in Years 12 and 13 for the final open pit closure pit backfilling operations.

**TABLE 16.6
OPEN PIT MINING SCHEDULE**

Item	Unit	Total	Y -1	Y 1	Y 2	Y 3	Y 4	Y 5	Y 6	Y 7
Pine Tree-Josephine Pit										
Total Pit Material	Mt	32.25	3.00	14.44	7.60	7.20	0.45			
Total Waste Material	Mt	23.93	2.74	12.00	4.39	4.70	0.11			
Strip Ratio	W:O	2.9								
Total Mineralization (all types)	Mt	8.83	0.33	2.44	3.22	2.79	0.33			
Total Mineralized Material to Process Plant	Mt	8.31	0.26	2.00	3.21	2.50	0.33			
Au grade	g/t	1.80	1.63	2.08	1.64	1.73	2.13			
Oxide Mineralized Material to Heap Leach	Mt	0.51	0.07	0.44						
Au grade	g/t	0.93	1.15	0.90						
Queen Specimen Pit										
Total Pit Material	Mt	12.82						5.94	4.08	2.80
Total Waste Material	Mt	10.68						5.19	3.33	2.16
Strip Ratio	W:O	5.0						6.9	4.4	3.4
Total Mineralization (all types)	Mt	2.14						0.75	0.75	0.64
Total Mineralized Material to Process Plant	Mt	2.14						0.75	0.75	0.64
Au grade	g/t	1.31						1.14	1.26	1.57
Total Open Pit										
Total Pit Material	Mt	45.07	3.00	14.44	7.60	7.20	0.45	5.94	4.08	2.80
Total Waste Material	Mt	34.61	2.74	12.00	4.39	4.70	0.11	5.19	3.33	2.16
Strip Ratio	W:O	3.3	10.4	6.0	1.4	1.9	0.3	6.9	4.4	3.4
Total Mineralization (all types)	Mt	10.97	0.33	2.14	3.22	2.79	0.33	0.75	0.75	0.64

**TABLE 16.6
OPEN PIT MINING SCHEDULE**

Item	Unit	Total	Y -1	Y 1	Y 2	Y 3	Y 4	Y 5	Y 6	Y 7
Total Mineralized Material to Process Plant	Mt	10.45	0.26	2.00	3.21	2.50	0.33	0.75	0.75	0.64
Au grade	g/t	1.70	1.63	2.08	1.64	1.73	2.13	1.14	1.26	1.57
Oxide Mineralized Material to Heap Leach	Mt	0.51	0.07	0.44						
Au grade	g/t	0.93	1.15	0.90						
Contained Gold to be Processed	oz	569,964	13,784	133,868	169,794	139,456	22,933	27,416	30,382	32,330

**TABLE 16.7
OPEN PIT EQUIPMENT FLEET**

Item	-1	1	2	3	4	5	6	7	8	9	10	11	12	13
Drill, 250 mm, Crawler, Rotary	1	2	1	1	1	1	1	1						
Stemming Truck, 15 t	1	1	1	1	1	1	1	1						
Transport for Detonators	1	1	1	1	1	1	1	1						
Hydraulic Shovel, 10 m ³	1	2	1	1	1	1	1	1					1	1
Wheel Loader, 12 m ³	1	1	1	1	1	1	1	1	1	1			1	1
Haul Truck, 91 t	3	6	4	4	2	8	6	5	1	1			4	7
Personnel Van/Bus	1	1	1	1	1	1	1	1						
Dozer D10	3	3	3	3	3	3	2	2	1	1				
Welding Truck	1	1	1	1	1	1	1	1						
Excavator, 4 m ³	1	1	1	1	1	1	1	1						
Fuel Truck	1	1	1	1	1	1	1	1	1	1				
Grader, 16H-Class 16' Blade	2	2	2	2	2	2	2	2	1	1				
Light Plant	4	4	4	4	4	4	4	4	2	2				

**TABLE 16.7
OPEN PIT EQUIPMENT FLEET**

Item	-1	1	2	3	4	5	6	7	8	9	10	11	12	13
Lube Truck	1	1	1	1	1	1	1	1	1	1				
Mechanic Truck	1	1	1	1	1	1	1	1	1	1				
Pickup Truck	8	8	8	8	8	8	8	8	2	2				
Pit Water Pumps Diesel	1	1	1	1	1	1	1	1						
Flat Deck w Hiab	1	1	1	1	1	1	1	1						
Forklift	1	1	1	1	1	1	1	1						
Water truck, (40 t 8,000 Gallon)	1	1	1	1	1	1	1	1	1	1				
Drill, 90 mm, Crawler, Percussion	1	1	1	1	1	1	1	1						
Trailer, Lowboy	1	1	1	1	1	1	1	1						

**TABLE 16.8
OPEN PIT PERSONNEL**

Personnel	-1	1	2	3	4	5	6	7	8	9	10	11	12	13
Driller	2	6	3	3	1	3	2	2						
Driller Helper	2	6	3	3	1	3	2	2						
Blasting Foreman	1	1	1	1	1	1	1	1						
Blaster	1	1	1	1	1	1	1	1						
Labourer	1	1	1	1	1	1	1	1						
Truck Drivers	5	22	14	13	2	31	22	16	2	2			13	25
Shovel Operator	3	6	3	3	1	3	2	2					3	3
Loader Operator	1	1	1	1	1	1	1	1	1	1			1	1
Heavy Duty Mechanic	5	20	13	12	1	16	12	10	2	2			9	12
Grader Operator	4	4	4	4	4	4	4	4						
Dozer Operator	8	8	8	8	8	8	6	6	2	2				

**TABLE 16.8
OPEN PIT PERSONNEL**

Personnel	-1	1	2	3	4	5	6	7	8	9	10	11	12	13
Water Truck Operator	4	4	4	4	4	4	4	4	2	2				
Utility Operators	2	2	2	2	2	2	2	2						
Mine Superintendent	1	1	1	1	1	1	1	1						
Mine General Foremen	1	1	1	1	1	1	1	1						
Mine Foremen	4	4	4	4	4	4	4	4						
Maintenance General Foreman	1	1	1	1	1	1	1	1						
Maintenance Foreman	2	2	2	2	2	2	2	2	1	1				
Planner	1	1	1	1	1	1	1	1	1	1				
Welder	2	2	2	2	2	2	2	2	1	1				
Gas Mechanic	2	2	2	2	2	2	2	2						
Tireman	1	1	1	1	1	1	1	1	1	1				
Partsman	1	1	1	1	1	1	1	1						
Laborer	2	2	2	2	2	2	2	2						
Equipment Trainer	1	1	1	1	1	1	1	1						
Chief Engineer	1	1	1	1	1	1	1	1						
Senior Mine Engineer	1	1	1	1	1	1	1	1						
Mine Engineer	1	1	1	1	1	1	1	1						
Geologist	1	1	1	1	1	1	1	1						
Surveyor	1	1	1	1	1	1	1	1						
Survey Tech	1	1	1	1	1	1	1	1						
Mine Tech	1	1	1	1	1	1	1	1						
Grade Control Tech	1	1	1	1	1	1	1	1						
Total	66	109	85	83	55	105	87	79	13	13			26	41

16.1.4.1 Waste Rock Storage

Waste rock mined from each pit will have different destinations. Table 16.9 describes the waste rock balance.

Item	Unit	Pine Tree- Josephine Pit	Queen Specimen Pit	Road Cuts	Total
Total Open Pit Waste	Mt	23.9	10.7	2.8	37.4
Total Open Pit Waste	Mm ³	11.3	5.0	1.3	17.6
Fill for Highway Bypass	Mm ³	1.2			1.2
Fill for haulroad to Queen Specimen Pit	Mm ³	0.4			0.4
Backfill directly in Pine Tree-Josephine Pit	Mm ³	1.0	5.0		6.0
Waste to Pine Tree-Josephine Waste Storage	Mm ³	9.9			9.9
Total	Mm³	12.5	5.0		17.6
Pit Backfilling					
Backfill Rehandle to Pine Tree-Josephine Pit	Mm ³				4.1
Backfill Rehandle to Queen Specimen Pit	Mm ³				4.2
Remaining in Waste Storage	Mm ³				1.6

Pine Tree-Josephine Pit: Initial waste rock from the Pine Tree-Josephine Pit will be used to build roads and the highway bypass. The remaining waste rock will be placed into the large waste rock storage facility to the east of the Pine Tree-Josephine Pit (see the site layout in Figure 18.1). A minor amount (1 Mt) of waste rock mined in Phase 3 will be placed into the lower portions of the Phase 1 Pine Tree-Josephine Pit.

Queen Specimen Pit: All of the waste rock mined from this open pit will be placed into the Pine Tree-Josephine Pit, as part of the required backfilling operation. Approximately half of the Pine Tree-Josephine Pit will be backfilled during Queen Specimen open pit mining.

Backfilling: At the cessation of mining, it is required to backfill the open pits near to original topography. Backfilling the Pine Tree-Josephine Pit will require an additional 8.7 Mt (4.1 Mm³) reclaimed from the large waste storage facility. The Queen Specimen Pit will also require 8.9 Mt (4.2 Mm³) of waste rock to be re-handled from the large waste storage facility. Ultimately approximately 3.5 Mt (1.6 Mm³) will remain in the waste storage facility.

For the purposes of this PEA the waste rock storage facilities were not designed in detail, however, potential sites were identified and field reconnaissance will be done at the next stage of study to confirm the preferred locations. Past Feasibility Studies used the same sites.

The tailings dry stack storage facility will be located adjacent to the process plant site. There may be the opportunity to place dry stack material within the Pine Tree-Josephine Pit, which would require a longer transport distance compared to the planned facility near the process plant. An evaluation of the environmental impacts will be required since underground mining will be occurring beneath the Pine Tree-Josephine Pit.

16.1.4.2 Mine Support Facilities

The Fremont Gold open pit operations will require mine offices, maintenance facilities, warehousing, and storage areas.

A maintenance shop area and fuel and lube station will also be required.

16.2 UNDERGROUND MINING

This section covers the portion of the Mineral Resource amenable to underground mining and outside of open pit mining areas.

16.2.1 Introduction

The Fremont Deposit is comprised of eight mineralized domains in two distinct groupings: the mineralized domains of the Pine Tree-Josephine (“PTJ”) area and the Queen Specimen (“QS”) area. The QS area was determined to be uneconomical to mine using underground methods and is not included in the following sections.

The PTJ area is approximately 1.0 km along strike and extends to a maximum depth of approximately 750 m below surface (20 masl). PTJ contains historical workings that reach a maximum depth of 625 m below surface (160 masl) and extend over the entire strike of the area in upper levels (560 masl and above), decreasing to 150 m in strike at the lowest level (190 masl). Historical vertical development extends 30 m below the lowest level.

Extraction of mineralization will utilize Longhole (“LH”) stoping, either on longitudinal retreat or, in areas where sufficient thickness and grade exists, with transverse access. Approximately 33% of the extracted tonnes will be from transverse mining, with the remaining 67% from longitudinal retreat. Figure 16.4 shows the historical development relative to the current stopes and extents of the mineralized domains. A stand-off distance of 3.1 m (10 ft) to all old workings, both development and stopes, has been applied to reduce the potential for rock stability issues surrounding historical voids. Existing workings have not been integrated in the new mine plan.

FIGURE 16.4 UNDERGROUND MINE EXTENTS

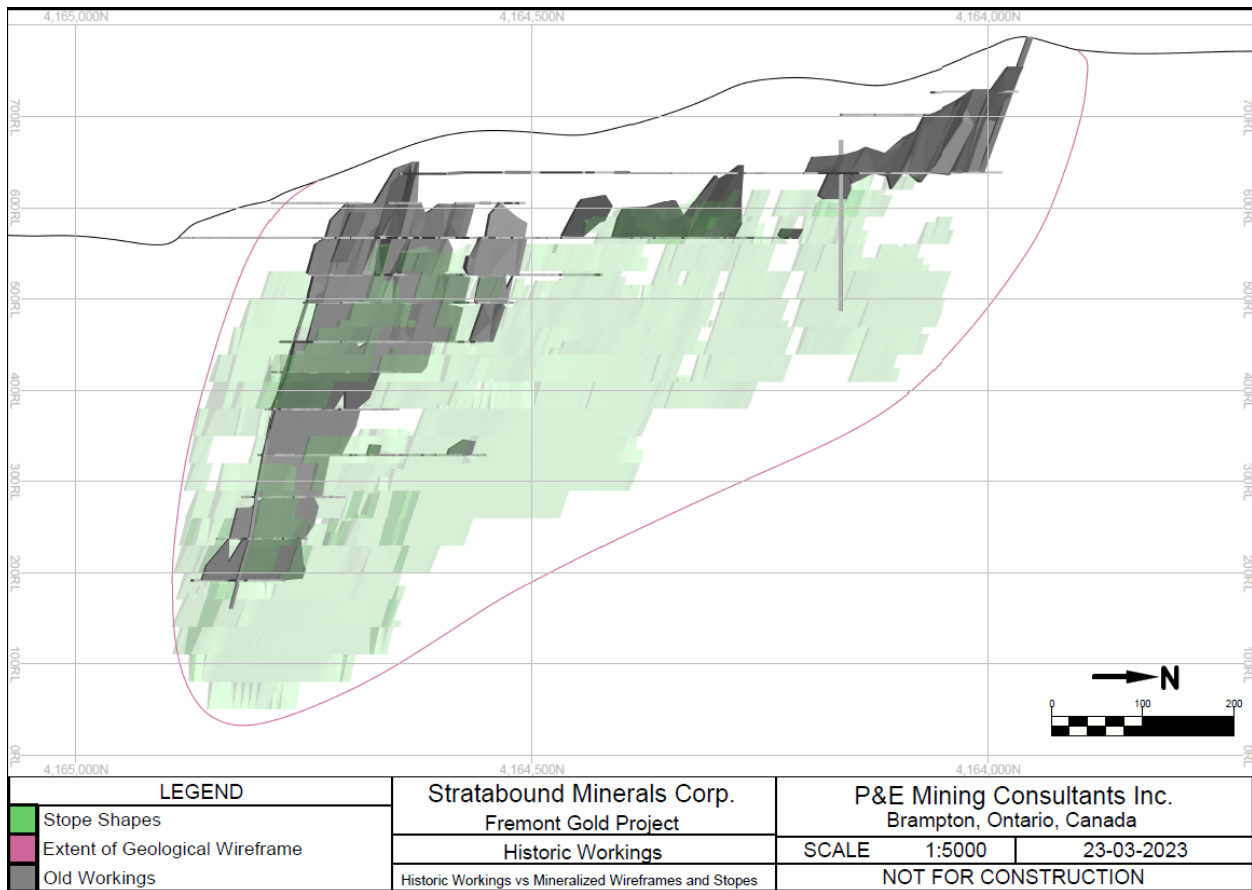

Backfilling for the underground mine utilizes paste backfill (“PF”) to both ensure effective support of voids, and to maximize the use of process plant tailings in backfill, thereby limiting the environmental impact of surface tailings storage. PF is expected to use three recipes: a high-strength recipe for areas utilized as artificial sill pillars, a low-strength recipe for areas where only the stope walls will be exposed, and a minimum-strength recipe for areas where the stope walls will never be exposed. It is also possible that for mining areas that will never be exposed, development waste rock fill with no binder content could be used as backfill. Approximately 20% of all stopes will be filled with high-strength PF, 75% with low-strength PF, and 5% with either minimum-strength PF or waste rock fill.

The mine has been designed utilizing a Railveyor™ (“RV”) haulage system to minimize costs associated with transporting mined material over significant lateral and vertical extents from the underground mine to the surface waste storage facilities or process plant. The low operating cost of the system, coupled with its zero-emissions electrical drive, provide significant economic and environmental benefits to the Project. The RV route includes an underground portion extending approximately 1,600 m (inclusive of ramp and loading level), and a surface portion extending 2,600 m from the underground portal to the tipping points. Figure 16.5 shows the extents of the RV system.

FIGURE 16.5 RAILVEYOR™ ROUTE

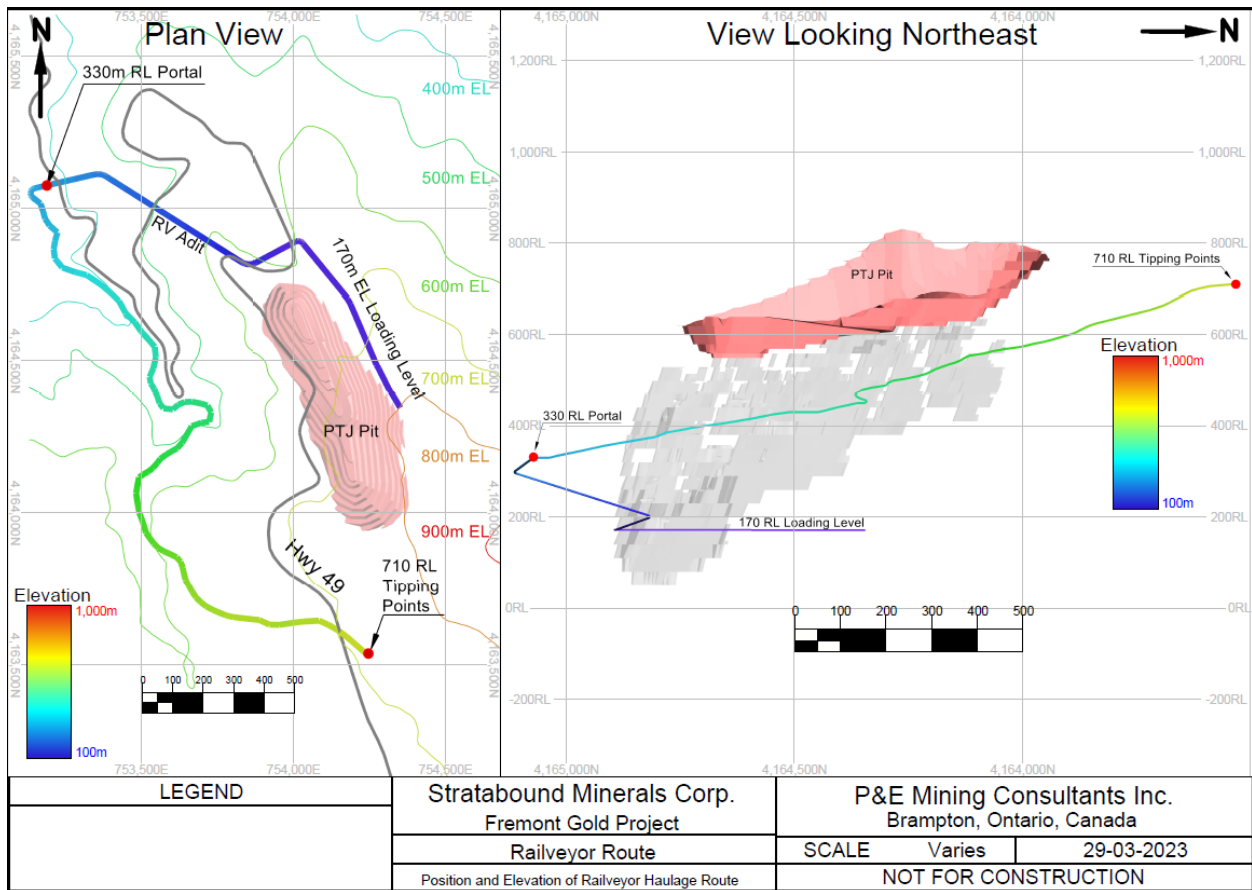

Capital development is sized to support 30 t haul trucks and 10 t Load-Haul-Dump (“LHD”) units, with a main ramp and the majority of CAPEX drift and ramp development sized at nominal 4.5 m W x 4.5 m H, and level operating development sized at 4.0 m W x 4.0 m H. A portal located at 330 masl provides primary access to the underground. A designated ramp for the RV is driven parallel to the main adit ramp to a loading level at 170 masl. The main ramp is then driven upwards and downwards to the vertical extents of underground mining. Above the 200 masl level, passes are used to transport broken material to the RV loading level. Below 200 masl, broken material passes are used to transport material to a truck loadout at 20 masl. Material from the truck loadout is transported to the 200 masl level and dumped into the RV system for final transport out of the mine.

To support a 4,000 tpd production target, multiple mining areas will be in production simultaneously. The mine is divided into four mining blocks to facilitate this. Production begins in the lower blocks and progresses upwards as development reaches new blocks. This bottom-up approach was selected to optimize ounces in the earlier years of production, as higher-grade areas are generally located deeper in the mine. For each mining block above the lowest (Block 4), stopes on the bottom level will be backfilled with high-strength PF to create an artificial sill pillar and allow eventual undermining by the block below. A zone of influence (pit bottom pillar) extending 30 m below the open pit limits has been utilized to prevent interaction between the underground and open pit mining. Stopes within this zone will be excavated after the end of open pit life at a

reduced mining recovery. A similar crown pillar was evaluated for original topography and does not impact any underground mining areas. Figure 16.6 shows the distribution of the mining blocks, pillars, and stope grades in the underground mine.

FIGURE 16.6 MINING BLOCKS AND STOPE GRADES

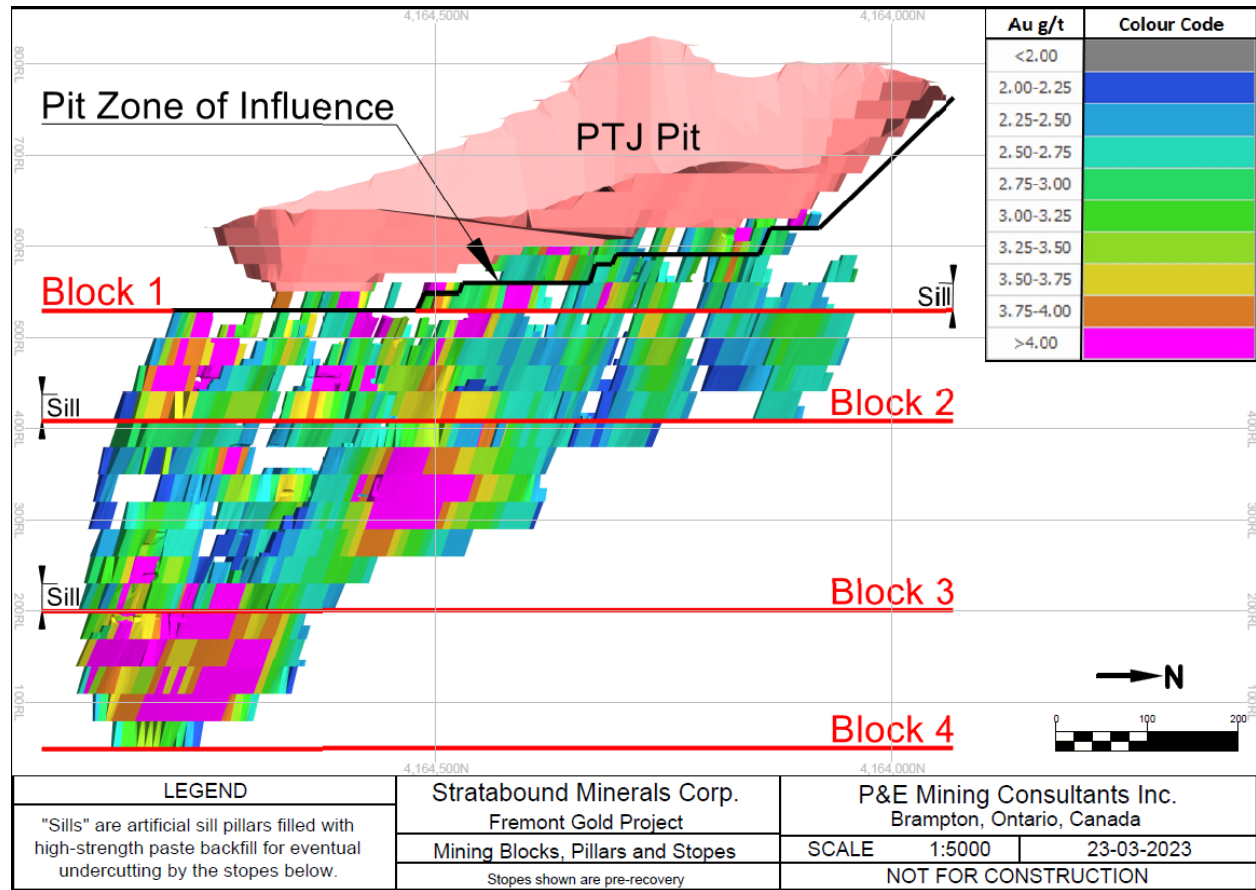

Services (ventilation, power, dewatering, etc.) will be provided down two fresh air raises located at the northwest and southeast of the mine. PF will be provided through boreholes running approximately parallel to the ventilation raises.

Mining and development will be performed entirely by Company personnel, with a fleet acquired through a lease-to-own strategy.

The underground mine in the PTJ area is expected to produce 4,000 tpd over a life of nine years, including a one-year ramp-up period. Pre-production development is expected to take one year. A total of 11.4 Mt grading 3.12 g/t Au are estimated to be produced, containing 1.14 Moz Au.

16.2.2 Mine Planning Criteria

16.2.2.1 Mining Parameters

The initial design of the underground mining complex considered the following parameters:

- Initial production methods of:
 - Sub-level caving without additional backfill (similar to New Afton).
 - Sub-level caving with additional un-cemented backfill (similar to Lac des Iles).
 - Longhole stoping with PF (similar to Goldex and numerous others).
 - The Deposit was determined to be physically amenable to caving methods. However, the lack of selectivity and increased initial CAPEX made these less economically attractive versus longhole stoping with PF.
- Initial parameters of:
 - 92% mining recovery.
 - 13% external dilution.
 - 30 m mining level intervals.
- Preliminary Deswik Stope Optimizer (“DSO”) stopes at 2.0 g/t Au cut-off grade (“COG”) totalling:
 - 16 Mt at 3.1 g/t Au.
 - 75% conversion from DSO to final mining plan.
 - Total mine production plan of 12.5 Mt.
- Preliminary production rate estimates:
 - Taylor’s Rule (Taylor, 1986) of 3,006 tpd.
 - Modified Taylor’s Rule (Long, 2009) of 2,892 tpd.
 - Production rate of 4,000 tpd selected due to open pit influences on overall Project production rate and the ability to mine multiple mining blocks concurrently.
- Use of high strength cemented PF to eliminate in-situ pillars, reduce backfill transport costs, and decrease final surface tailings storage requirements.
- Stope productivity of 360 tpd per stope (average), varying from 200 to 550 tpd depending on the access type (longitudinal or transverse) and the geometry of the stope.
- Haulage via RV system, material handling via passes:
 - A trade-off analysis was performed that indicated that the RV system, while capital-intensive, provides a positive NPV benefit through significantly reduced OPEX, while also reducing diesel usage and, consequently, site greenhouse gas emissions.

16.2.2.2 Railveyor™

The RV system is a materials handling system that utilizes stationary drive stations to move connected train cars that create a trough along a network of rails. The RV operates in a very low friction regime with a high ratio of load to dead weight versus other tracked or trackless haulage systems. These features result in a highly energy efficient haulage process, with low maintenance and operating costs, and its fully electric drive system produces no greenhouse gas emissions.

The trough size specified for the Fremont Project is capable of transporting large broken rock material up to 0.61 m. Broken rock material will be fed through a series of broken rock material to reclaim feeders, which will be used to load the RV trains as they pass under the hopper (this arrangement is currently in use at Doe Run Mines in Missouri). The ability of the RV to handle large broken rock material sizes negates the need for underground crushing, further reducing costs.

Another significant benefit of the RV is its ability to operate at gradients of up to 30%, significantly steeper than haul trucks. This is beneficial as the surface haulage route from the portal to the process plant using the existing highway averages 7.6% grade over 4.9 km. The RV, utilizing a maximum gradient of 25%, allows for a significantly reduced distance of 2.6 km at an average gradient of 15% (portions of the haul route transit over relatively flat terrain, reducing the average gradient). In the underground mine, the gradient of the RV adit is limited by the ability of trackless machinery to drive the face and transport broken material from the face to the RV. The RV adit is driven at a nominal 17% average grade versus a nominal 12.5% average grade for a normal trackless drift, reducing the length of the initial adit by nearly 300 m.

Since the RV is an autonomous system controlled by computer routing, it operates in a designated area segregated from pedestrian or vehicle traffic. In the Fremont underground mine, this includes a designated adit parallel to the main adit at a nominal profile of 4.0 m W x 4.0 m H, and a designated loading level at 160 masl with the same profile. To accommodate drive stations with a minimum width of 4.5 m, cut-outs will be taken as necessary in the walls of both drifts. RV trains are estimated at 300 m in length, and passing will be accomplished using over/under arrangements to minimize drift width, as shown in Figure 16.7. Dumps will utilize a loop configuration, where the entire train is inverted during dumping to prevent carry-back, as shown in Figure 16.8. Two dumps will be installed, one for mineralized material, which dumps on the ROM, and another for waste material, dumping on a stockpile for eventual re-handling to the waste rock storage facility. The RV is sized to accommodate a nominal 5,000 tpd of material throughput from the loading level to the dumps. Weight scales are included in the system to ensure correct loading and allow better reconciliation of throughput.

FIGURE 16.7 RAILVEYOR™ CROSS-SECTION

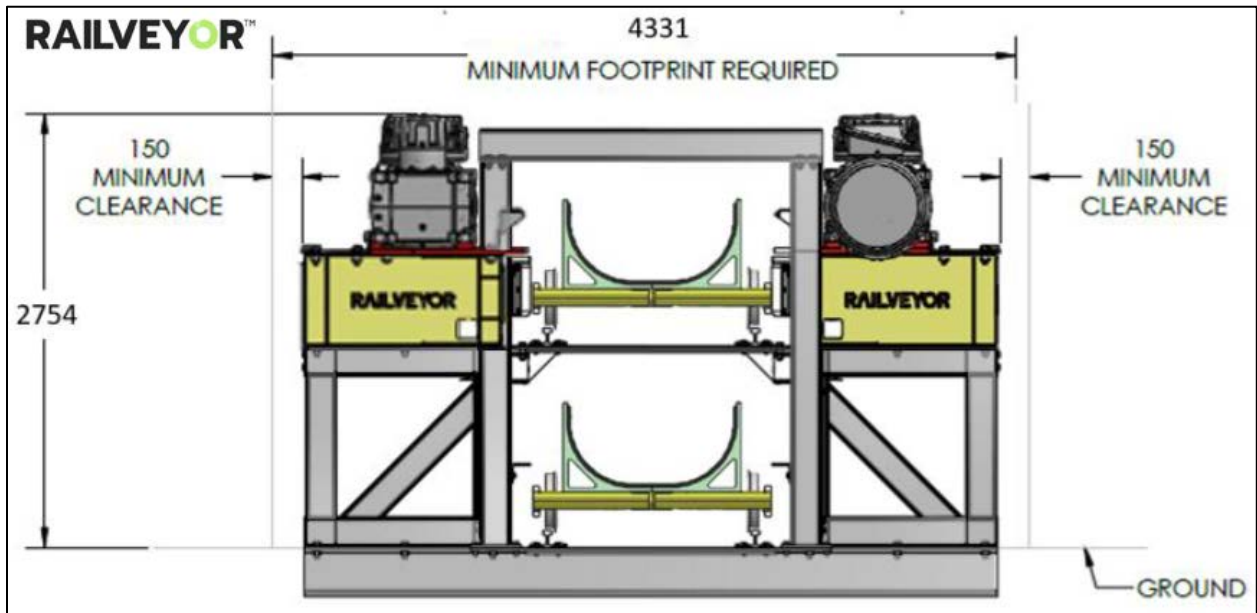

Source: Railveyor™

FIGURE 16.8 RAILVEYOR™ LOOP CONFIGURATION

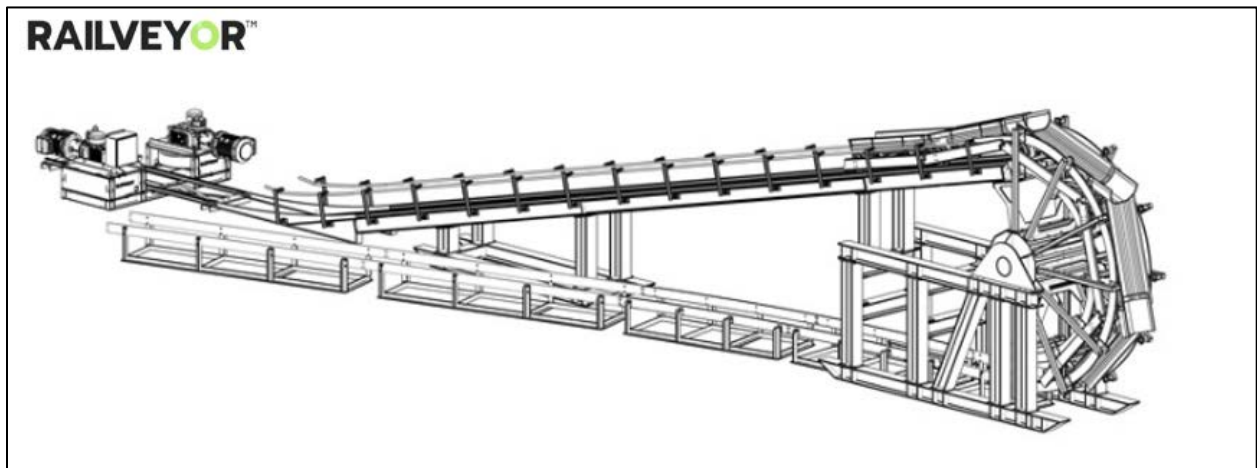

Source: Railveyor™

16.2.2.3 Cut-off Grade

Table 16.10 shows the Cut-Off Grade (“COG”) calculations.

TABLE 16.10 INITIAL CUT-OFF GRADE PARAMETERS			
Parameter	Unit	Marginal COG	Incremental (Development) COG ¹
OPEX Development	\$/t	5.00	0
Mining	\$/t	34.50	2.00
Backfilling	\$/t	5.00	0
Processing	\$/t	12.00	12.00
Refining	\$/t	6.50	6.5
G&A	\$/t	2.50	2.50
Total	\$/t	65.50	23.00
Recovery ²	%	92	92
Payable ³	%	82	82
Gold Price	\$/oz	1,750	1,750
COG	g/t	1.5	0.5

Notes: COG = cut-off grade.

¹ Incidentally mined material from development that grades above this COG will be sent to the process plant.

² Recovery from the flotation circuit.

³ Payable on concentrate from flotation circuit.

A multi-variable analysis of tonnes, cut-off grades and mining rates was performed that resulted in the selection of a higher COG to better balance NPV and IRR considerations. Final stope shapes were created using a 2.0 g/t Au COG.

16.2.2.4 Deswik Stope Optimizer (DSO)

DSO was used to generate all stope shapes. This program algorithmically analyzes incremental changes in stope shape and size within a series of set parameters to create the maximum value shape meeting the parameters. DSO shapes in 0.1 g/t Au increments above the Marginal COG were utilized in the analysis to determine optimal balance of IRR and NPV.

16.2.3 Geotechnical Considerations

No geotechnical analysis of the Deposit has been performed. The Authors have estimated all parameters and recommend additional geotechnical work in future studies of the Project. Based on limited geotechnical logging of drill core, rock quality in the Fremont underground has been estimated as “Good”, with stability factor (N) of 10.

16.2.3.1 Stope Sizing

Level spacing was analysed and a 30 m interval was selected as the best balance between drilling capabilities, capital development costs, and the influence of existing openings. Stope strike length will be limited to 40 m for a consideration of Hydraulic Radius (“HR”), and stope spans are limited to 20 m as an operational consideration to prevent extraction losses in corners. The resulting HR of any wall of the stope is limited to a value under 8, which is expected to be the upper end of unsupported stability using the Matthew’s Stability Graph Method, and easily supportable with additional support if necessary. In general, transverse stopes are the largest stopes in the mine, with longitudinal stopes being limited on strike to 30 m to reduce the potential for additional ground support.

16.2.3.2 Crown

A 30 m crown pillar below surface was estimated for the Project. All stope shapes generated in the 2.0 g/t Au DSO stope set within 30 m of surface are within the boundaries of the open pit and are not directly affected by the crown pillar.

16.2.3.3 Pit Pillar / Zone of Influence

A zone of influence of 30 m was projected around the maximum extents of the open pit to examine the effects of an exclusion zone similar to the crown pillar applied below the limit of the open pit. This zone intersects portions of the top four mining levels of the underground mine. It was deemed feasible to extract most stopes within this zone of influence after the end of open pit operations, and at a reduced mining recovery and increased dilution, with backfill from the open pit. All stopes in the mine plan within this zone have mining recovery reduced to 70% and an additional 5% dilution added, are to be mined on retreat using remote-controlled machinery to reduce hazards to personnel, and are not to be mined until open pit operations are complete. It is anticipated that some stopes will be drilled using downholes from the open pit floor, while others will be drilled using upholes from the underground. A total of 2% of all tonnes mined from the underground are affected by this zone.

16.2.3.4 Artificial Sill Pillars

To facilitate the 4,000 tpd production rate, multiple mining fronts are needed. As such, the underground mine is divided into four vertically separate mining blocks. Mining progresses from the bottom of each block to the top. The lowest level of each block, with the exception of the lowest level in the mine, will be backfilled with high-strength PF to create an artificial sill pillar. These pillars will be of sufficient strength to be self-supporting when undercut by further mining. All mining in stopes directly under the artificial sill pillars will be done using remote machinery once blasting is complete.

16.2.3.5 Stand-off to Historical Workings

Historical workings exist over a significant portion of the underground mining area. As relatively good survey data exists, and relatively recent investigation of the underground workings indicates they have not caved significantly, a 3.1 m (10 ft) exclusion zone has been placed around all existing

workings, with no development or production planned within these areas. In practice, it is normally possible to mine through existing development, and it may be possible to utilize existing production voids for backfilling or other purposes. However, for the purposes of this PEA any material within the stand-off area has been excluded from the mine plan.

16.2.4 Development

Development in the underground uses standard trackless development methods, with 10-t class LHDs, 2-boom development jumbos and 30-t class haulage trucks. Vertical development is predominately driven by contractors using Alimak methods, however, a minority of metres are excavated using longhole drop raises. Ground support is installed using mechanized bolters and is expected to include wire mesh and rebar in CAPEX development, and a combination of wire mesh, rebar and split sets in mineralized OPEX development. Allowance has been made for the installation of long support methods in development intersections. Figure 16.9 shows the extents of underground vertical and lateral development.

FIGURE 16.9 UNDERGROUND DEVELOPMENT SCHEMATIC

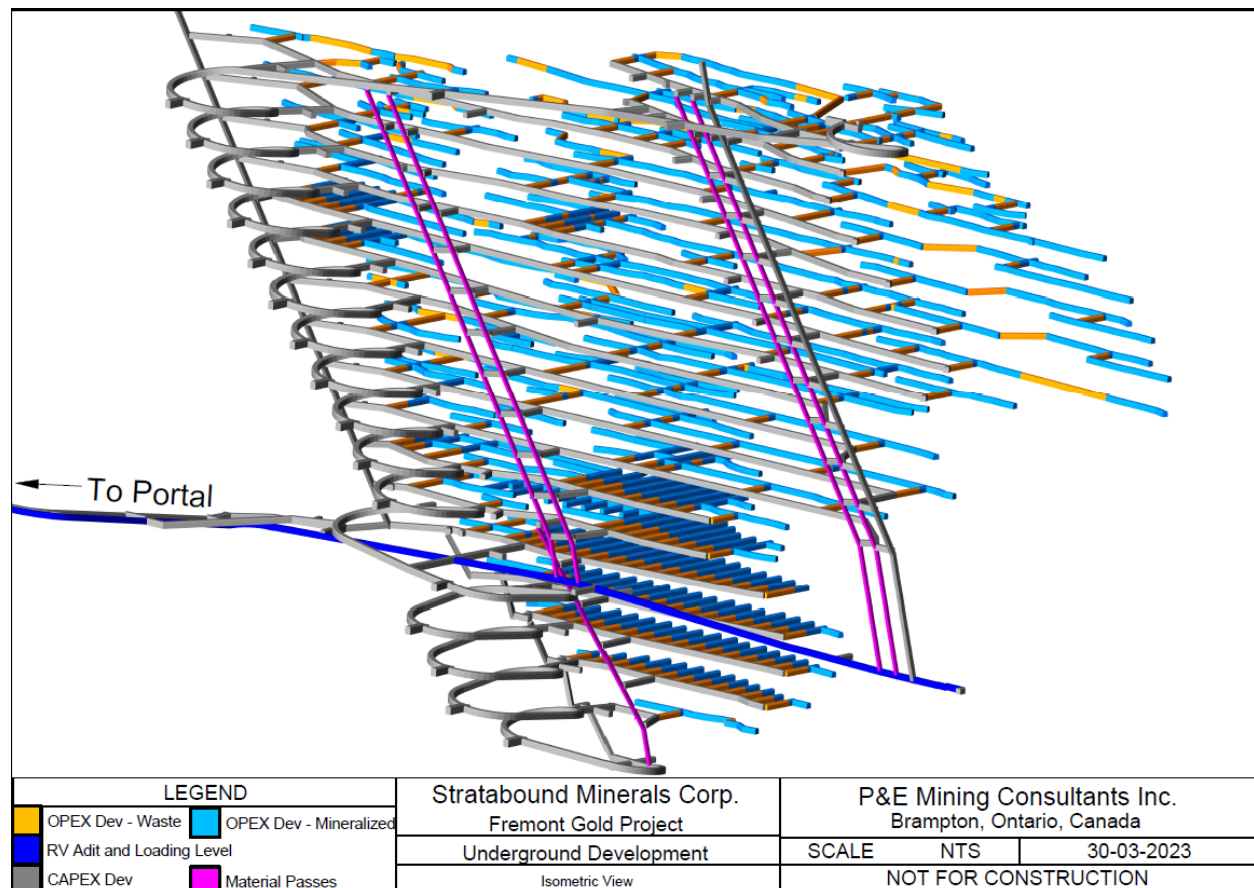

16.2.4.1 Lateral Development

Table 16.11 shows lateral development totals by profile and purpose. All profiles are nominally rectangular in section, however, in practice are expected to be excavated with rounded shoulders.

TABLE 16.11 LATERAL DEVELOPMENT			
Type	Profile	Purpose	Quantity (linear m)
CAPEX	4.0 m W x 4.0 m H	Dewatering	350
		Electrical	519
		RV Loading Level	706
		RV Adit	995
		Pass Accesses	1,246
		Ventilation Accesses	971
	4.5 m W x 4.5 m H	Main Ramp	5,435
		Level Accesses	806
		Footwall Drifts	7,315
4.5 m W x 5.5 m H	Remuck Bays	504	
OPEX	4.0 m W x 4.0 m H	Mineralized OPEX Development	17,947
		Waste OPEX Development	5,905
Total			42,697

16.2.4.2 Vertical Development

Table 16.12 shows vertical development totals by profile and purpose. All profiles are nominally rectangular in section. All vertical development will be scaled, bolted, and screened as required. This is a necessity for the safe driving of Alimak raises, and all drop raises will be utilized as emergency egresses with ladderways, necessitating ground support and screen. Broken material passes are expected to be shotcreted, instead of screened, to reduce abrasion from material in the pass and increase the useable life of the pass.

TABLE 16.12 VERTICAL DEVELOPMENT			
Type	Profile	Purpose	Quantity (linear m)
CAPEX	3.1 m W x 3.1 m L	Ventilation Raises - Drop Raise	175
		Ventilation Raises - Alimak	1,033
		Broken Material Passes - Alimak	1,988
Total			3,196

Since initial access to the mine is at the 170 masl, the majority of ventilation raises and material passes must be driven bottom-up so that they are in place prior to lateral development breaking

through to them. Additionally, development will bypass levels, or portions of levels, to prioritize access to higher-grade mining blocks, so the ability to drive the raise independent of any development other than the bottom access is crucial. Alimak methods were selected for ventilation raises and broken material passes as, like raise bores, they are excavated from the bottom to the top, however, can be driven at a lower angle than raise bored openings and can change dip to better follow the mineralized domains. It is expected that, due to the length of the raises (over 500 m in some cases), it will be necessary to utilize electric-drive Alimaks instead of standard compressed-air powered units for improved efficiency. A specialized contractor will be used to drive the Alimak raises. All Alimak raises will be supported and either screened or shotcreted depending on their application.

16.2.5 Production

16.2.5.1 Mining

Production in the underground utilizes In-The-Hole Hammer (“ITH”) longhole drill rigs and 102 mm (4 inch) diameter drill holes loaded with ANFO to fragment the rock for excavating. Slot raises normally use a “Dice-5” pattern, however, large-diameter canister drills (Machine Roger V30) are used to drill initial slot raises in uphole stopes to provide improved blasting performance. Drilling is estimated at 20% upholes and 80% downholes.

Explosives charging and priming activities occur from the overcut for downholes and from the undercut for upholes. 10-t class LHDs load broken mineralized material from the stopes to the passes, where the material transits to reclaim bins prior to being loaded into the RV system. Due to the design of levels, it is possible to segregate LHDs tasked with production from other equipment and personnel through “soft” barriers such as laser gates. This achieves a high degree of automation in the excavation process, improving productivity and reducing the number of required operators. Cemented PF is pumped from surface to the underground through 102 mm (4 inch) diameter pipes. PF is expected to be cured to sufficient strength for adjacent production blasting after 14 days, with drilling expected to be able to commence after a maximum of three days.

16.2.5.2 Dilution

Dilution, either internal (from deliberate inclusion in a mining shape) or external (incidental as a result of overbreak or poor drilling/blasting practices) adds additional tonnes below COG to a mining plan. Dilution estimates are based on first principles calculations and on the Author’s experience at other mines using the same mining methods, and are as follows:

- Floor gouge depth of 0.3 m.
- Sidewall overbreak on longitudinal stopes averaging to an equivalent of 0.5 m on both sides (1.0 m total).
- No sidewall overbreak on transverse stopes.
 - Primary stope overbreak is into adjacent mineralization.
 - Blasting of secondary stopes normally breaks to the PF/virgin rock contact.

- End members of transverse groups where sidewall overbreak could be into unmineralized material comprise a total of 2% of tonnes, therefore, this scenario is ignored.
- Endwall overbreak (one end only) of 0.6 m.

An additional 5% dilution is mathematically added to all stopes affected by the Pit Pillar exclusion zone of influence. Dilution in sidewalls is interrogated against the block model to determine the quantity of mineralization included within it. Floor gouge, endwall overbreak, and additional dilution in the Pit Pillar zone of influence are assumed to have zero grade.

Total average external dilution on underground stopes is estimated at 13%.

16.2.5.3 Mining Loss

Mining loss is defined as a portion of material left behind in a stope due to any or all of blasting, loading, or ground support issues. All stopes other than those affected by the Pit Pillar exclusion zone of influence are assumed to have a mining loss of 8%, while those within the Pit Pillar exclusion zone of influence are assumed to have a mining loss of 30% to reflect additional complexities with mining in the area. Development is assumed to have a 99% recovery.

Total average mining loss on underground stopes is estimated at 9%.

16.2.5.4 Material Handling

Initial development of the underground mine utilizes standard trackless haulage, with LHDs loading trucks and the material being hauled to a temporary dump. Once the RV is installed, LHDs can load the RV directly using side-loading through connections between the main ramp and the RV ramp. From this point, the RV is used for all transport of mineralized and waste material out of the mine. Trucks will still be used when necessary to transport material to the broken material passes during development operations (e.g., when developing a new level prior to accessing the broken material passes on that level).

Material handling in the underground mine utilizes five broken material passes: three mineralized material passes and two waste rock passes. Below the loading level at 170 masl, a single pass is used to transport mineralized material to a central truck loadout at the 20 masl level, from where it is hauled up to the 200 masl level and transhipped into the RV system via the passes. Waste material is expected to be loaded in the level access of levels from 170 masl and below, and hauled and transhipped to the RV system in a similar fashion. All broken material passes are equipped with electrically-operated cover doors at each dump point (finger raise) to prevent short-circuits in the ventilation system and to limit “dusting out” of levels from the pass. Each dump point will also be equipped with a grizzly with 0.6 m passing size to segregate oversize. Oversize will be dealt with using secondary breaking in a re-muck bay if necessary, prior to re-entering the material handling system.

On the 170 masl loading level, reclaim feeders will be located at the bottom of each raise to allow selective loading of the RV trains. Computerized controls will be used to manage RV train traffic on a single main transit line with bypasses, to maintain broken material pass flow rates at optimal

quantities, and to ensure that the dump point for each train is assigned based on its source material pass, eliminating the risk of cross-contaminating broken material to either the run-of-mine (“ROM”) pad or the waste dump.

Figure 16.10 shows the underground broken material handling system.

FIGURE 16.10 LONGITUDINAL PROJECTION OF MATERIAL HANDLING SYSTEM

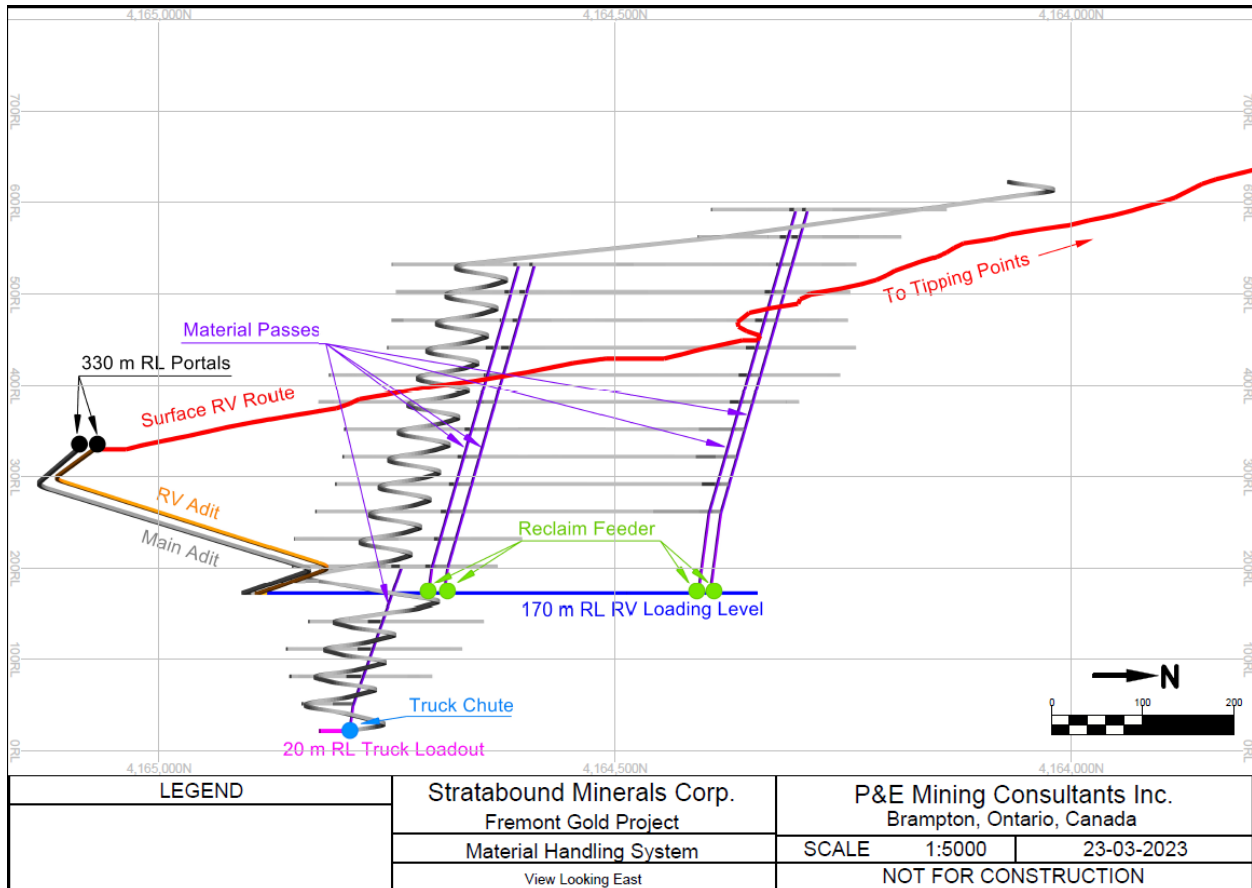

16.2.6 Mine Services

16.2.6.1 Backfill

A backfill plant will be constructed adjacent to the process plant for the purposes of manufacturing PF. The PF solids will be comprised of tailings and cement binder and will nominally be comprised of 70 to 75% solids by mass. Positive displacement pumps will be used to pump the PF from the plant through overland pipes to boreholes situated near the rim of the open pit and adjacent to the ventilation raises, from where it will transit to the underground levels. A total of 49% of tailings generated by processing underground mineralization will be utilized in PF to backfill the underground stopes. This total could be increased if historical voids are filled.

In the footwall drifts, 102 mm steel pipe will be used to transport the PF to the intersection of the stope access, and HDPE pipe of a similar diameter will be used to transport it to the stope. In situations where artificial pillars are being undermined and no overcut is available, longhole drills will be used to drill and ream a 152 mm (6 inch) service hole into the top of the open void, and HDPE pipe will be inserted into the stope through the drill hole. The annulus between the pipe and the walls of the hole will be used to vent displaced air during filling.

Fill walls in the undercuts will be constructed using off-the-shelf fill wall frames sprayed with shotcrete as necessary. In some cases, rammed rock and shotcrete can be utilized to reduce costs.

16.2.6.2 Ventilation

Initial ventilation will be provided using semi-rigid ducting in the adits until the Fresh Air Raise (“FAR”) from 170 masl to surface is completed. Once complete, a 2.13 m diameter fan with a 350 kW motor will be installed at the top of the raise to provide 100 m³/s of fresh air to the underground workings. Fresh air flow to each level will be governed by a small auxiliary fan or ventilation regulator at the FAR bulkhead in each level, and flow into the Return Air Raise (“RAR”), or the ramp will be governed by a similar setup at the RAR bulkhead. A booster fan of 2.13 m diameter with a 27 kW motor will be installed in the ventilation drift on the 170 masl production level to direct air down the drop-raised FARs to the bottom of the mine. Similar FAR controls will be installed on the lower FAR as the upper FAR.

Exhaust air will be directed to either the RAR (above 170 masl) or to the ramp (all areas of the mine) before reaching surface. Towards the end of mine life, the extreme upper levels of the mine (560, 590 and 620 masl levels) will be ventilated by drawing fresh air from the FAR at 530 m RL across the level and up the ramp prior to it exhausting out the upper RAR to surface. The RV loading level and adit will be entirely within the return (exhaust) air system.

Figure 16.11 shows underground ventilation and PF distribution systems.

FIGURE 16.11 VENTILATION AND PASTEFILL DISTRIBUTION SYSTEMS

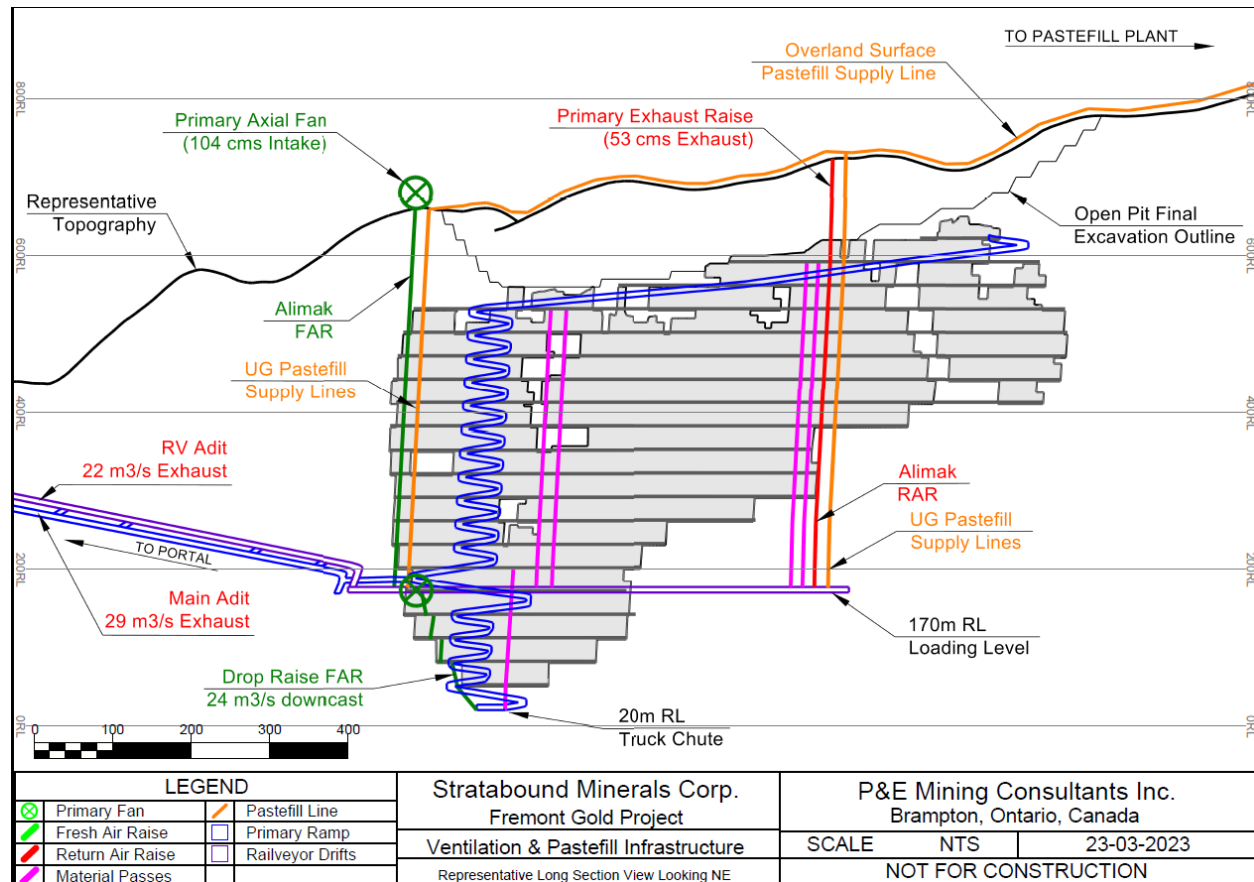

16.2.6.3 Dewatering

Electric submersible pumps will be installed at the working face and pump to the level sumps. Level sumps will cascade water via gravity to pump stations at the bottom of each mining block. Pump stations are equipped with settling sumps to segregate solids, and clean water sumps to recycle water into the service water system where possible. Excess water is pumped to surface via piping in the RAR for use in the process plant. Hydrogeological studies have not been performed on the Project, and the Authors have estimated water inflows at 8.5 L/s from groundwater and 10 L/s from service water, backfill flushing, and other sources. It is expected that 6 L/s of this water will be recycled into the service water system or lost through evaporation or transport in mined material, leaving a net positive balance of 12.5 L/s to be pumped to the process plant. The Authors recommend further investigation of the hydrogeological parameters of the underground at a later stage of study.

At each pump station, a submersible pump will be used in conjunction with a multi-stage centrifugal pump to move water to the next station above, in series. Each individual pump station has pumps sized to handle 100% of the mine flow, using 50% duty cycle at 25 L/s at 300 m head. Schedule 80 steel pipe of 102 mm diameter will be used for main dewatering lines.

16.2.6.4 Electrical Power

Electrical power will be supplied to the underground at a nominal 13.8 kV supply voltage, prior to being stepped down to 600 V at sub-stations for on-level reticulation. Substations will be located in the level access, with one substation servicing two active levels. Primary infrastructure (ventilation fans and the RV system) will utilize 1,500 kVa substations. Production areas will utilize 1,000 kVa substations. Development areas will utilize 750 kVa substations. A total of 13 substations will be installed at the maximum extents of mining. Maximum power draw is estimated at 4.1 MW in the second year of underground production, with a steady-state power draw of 3.6 MW. Maximum connected load also occurs in the same year, at 5.6 MW. Average steady-state electrical consumption will be approximately 31M kWh/yr. Figure 16.12 shows the electrical distribution and dewatering system for the underground mine.

FIGURE 16.12 ELECTRICAL DISTRIBUTION AND DEWATERING SYSTEM

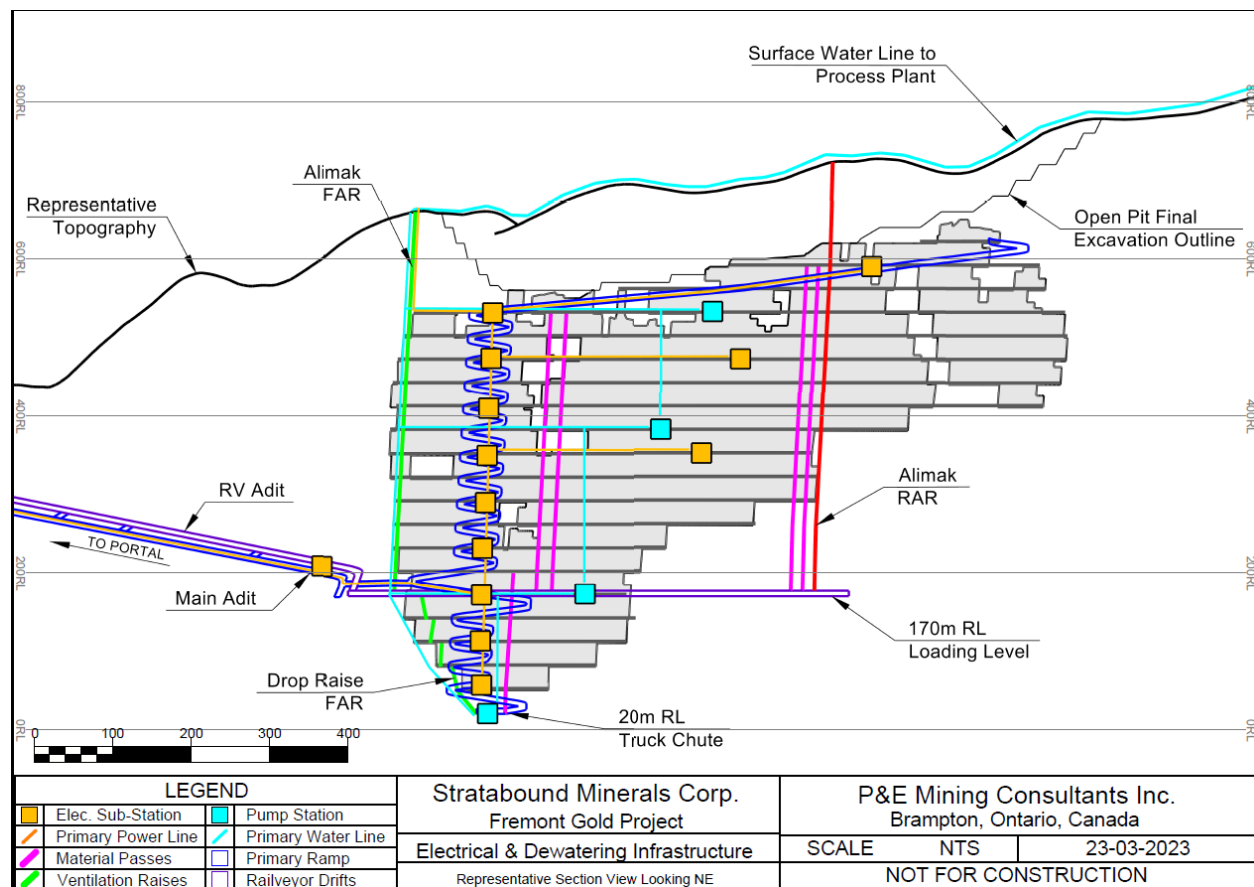

16.2.6.5 Other Infrastructure

Figure 16.13 shows the location of other significant infrastructure detailed in the following subsections.

FIGURE 16.13 UNDERGROUND INFRASTRUCTURE

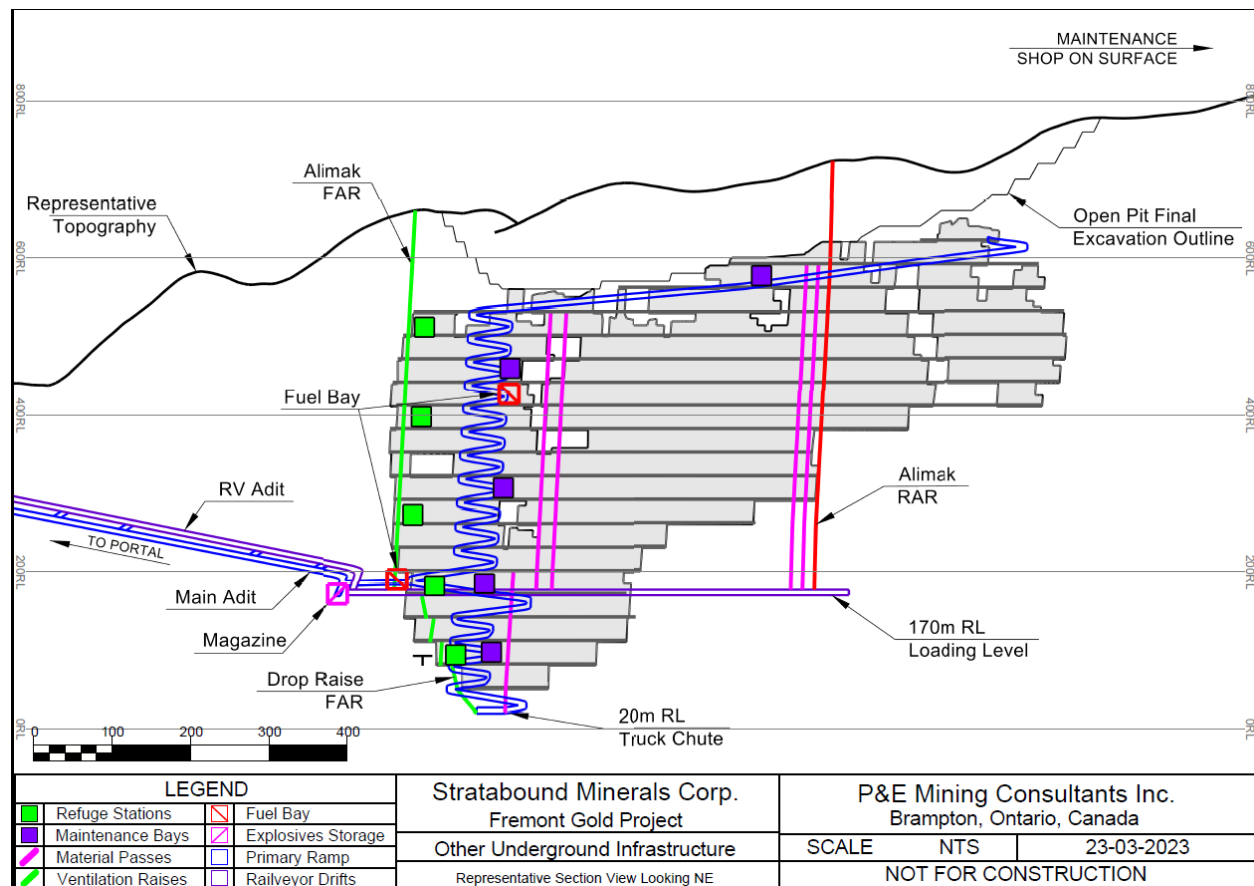

Refuge Stations and Egresses

Five refuge stations will be installed in the underground. The refuge stations will be equipped with compressed air, potable water, and first aid equipment; they will also be supplied with a fixed telephone line and emergency lighting. The refuge stations will be capable of being sealed to prevent the entry of gases, and equipped with airlocks to allow them to function as mine rescue bases. A refuge station will be installed near the intersection of the adit and the 170 masl level, with other stations being installed at the bottom of each mining block.

Ladderways will be installed from the Alimak climbers in the fresh air raise from surface at the NW end of the Deposit. Ladderways will also be installed in the drop-raised ventilation raises below the 170 masl level. This ensures that every level has at least two means of egress.

Compressed Air

Due to the large extents of the mine and the minimal requirement for compressed air due to selected equipment (electric-drive Alimaks, electro-hydraulic longhole drills, electric face pumps, etc.), a centralized compressed air distribution system has not been included. Equipment, where necessary, will be specified with onboard atmospheric compressors. Mobile compressor units will be utilized in areas where significant draw is expected (V30 drilling, primarily).

Fuel Storage and Distribution

A mobile equipment station for fuelling and lubrication, similar to a RockTech SatStat™, will be located on the 410 and 170 masl levels to provide fuel for the underground mobile equipment fleet. Additionally, there will be a fuel truck and a lube service truck to service the less mobile mining equipment (drills and jumbos). During development, fuel will be transported by a tank truck; prior to the installation of the first fuel station on 170 masl level. From this fuel bay, mine equipment can load fuel directly, or the fuel truck can load fuel and transport it to them.

Explosives Storage

Explosives and detonators will be stored on surface in approved magazines. A magazine for bulk explosives and a magazine for initiation systems will be installed at the 170 masl level prior to the start of production. Designated loading vehicles will load explosives from the appropriate magazine and transport them to production areas on a shift-by-shift or daily basis. Day boxes near active development faces will be used as temporary storage for daily explosive consumption.

The primary blasting agent used in the underground will be ANFO, however small quantities of packaged emulsion will be used where conditions require.

Communications

A Wifi-6 communications system will be installed in the underground mine to facilitate the transfer of data to and from the underground. This system will support the remote operation of machinery, real-time monitoring of mobile and fixed plant equipment, automated control of the materials handling system (RV, reclaim feeders and trucks chute), semi- or fully-autonomous operation of LHDs and LH drills in production areas, and provide high-quality audio communication among personnel.

Central Blasting

A central blasting system will be installed in the underground, which will allow the initiation of blasts remotely from a safe control point on the surface. Digital central blast systems will be sourced from a major supplier of explosives. These systems are extremely safe and contain redundancy coding that prevents accidental initiations, as well as reporting for blasts that fail to initiate. These systems will work through the mine Wifi-6 communications system.

Maintenance Facilities

Mobile underground equipment will be maintained in the surface maintenance shop located on surface. Preventative maintenance checks will be performed in designated maintenance bays underground, located in each mining block. A mechanic's truck equipped with a boom crane will be used to perform emergency repairs underground. Maintenance operations will be directed by the maintenance supervisor. A maintenance planner will ensure the availability of spare parts and supplies and a maintenance general foreman will provide direct management and supervision to maintenance crews.

16.2.7 Equipment

Table 16.13 shows the underground mine fleet at full production.

TABLE 16.13 UNDERGROUND FLEET			
Type	Role	Comparable Unit	Quantity
Mobile Equipment	Jumbo	Sandvik DD421	3
	LH Drill	Sandvik DU411	4
	Bolter	Sandvik DS421	3
	LHD (10 t)	Sandvik LH410	5
	Truck (30 t)	Sandvik TH430	3
	Grader	Elphinstone UG20K	1
	ANFO Loader	Kovatera MC100 system with specialty attachments by role	4
	Scissor Deck		4
	Fan/Pipe Handler		3
	Fuel/Lube		2
	Forklift/Utility		3
	Shotcreter		2
	Transmixer		Getman A64
	Light Vehicle	Polaris Ranger EV	10
Diamond Drill	Boart LM55	2	
Material Handling	Haulage System	Railveyor™ – Drive Station	98
		Railveyor™ – Train	4
	Reclaim Feeder	Komatsu RF-27	4
	Truck Chute	Variant Mining Technologies Standard Duty	1

Equipment will be acquired through a lease-to-own strategy. Mobile heavy equipment is expected to have a working life of five years, after which point it will be rebuilt. Light vehicles will be scrapped instead of rebuilt, and new units acquired. Reclaim feeders will be rebuilt once during the mine life. The truck loading chute will not be required later in mine life and will not be rebuilt.

16.2.8 Personnel

Table 16.14 shows the number of personnel by group at peak production. Some roles are rostered, some are dayshift only. The total represents the peak number of personnel on payroll for all rosters.

TABLE 16.14 UNDERGROUND PERSONNEL	
Role	Quantity
Development Operators	25
Production Operators	27
Services and Backfill Operators	21
Materials Handling / RV	3
Supervision and Management	9
Mining Department Subtotal	85
Mobile Maintenance	25
Fixed Plant Maintenance	21
Electrical Maintenance	14
Supervision, Planning and Management	10
Maintenance Department Subtotal	70
Engineering and Projects	13
Geology and Drill Core Shack	9
Admin, Procurement, HSE and Other	29
Ancillary Departments Subtotal	51
All Departments Total	206

16.2.9 Mine Plan

Table 16.15 shows the underground mine plan.

TABLE 16.15 UNDERGROUND MINE PLAN				
Group	Material Class	Mass (kt)	Contained Metal (koz Au)	Grade (g/t Au)
Fully Diluted Stopes	Indicated	1,985	215	3.37
	Inferred	9,625	1,035	3.35
	Waste	830	-	-
	Backfill	32	-	-
Mining Losses	Indicated	230	25	3.37
	Inferred	770	83	3.35
	Waste	50	-	-
Recovered Tonnes	Indicated	1,755	190	3.37
	Inferred	8,855	952	3.35
	Waste	781	-	-
Mineable Portion of	Indicated	1,885	190	3.14

TABLE 16.15 UNDERGROUND MINE PLAN				
Group	Material Class	Mass (kt)	Contained Metal (koz Au)	Grade (g/t Au)
Mineral Resource ¹	Inferred	9,506	952	3.12

Note: ¹ Waste has been distributed into the Mineral Resource classifications using tonnage weighting

A total of 11,391 kt grading 3.12 g/t Au and containing 1,132 koz Au is estimated to be mined from the Fremont underground mine.

16.2.10 Mine Schedule

16.2.10.1 Development Schedule

Table 16.16 shows the underground mine development schedule. Development has been scheduled using Equivalent Metres, a method of determining the total work required to advance a drift based on the area of the face. This method is used where faces of disparate sizes are expected to be excavated concurrently in multiple locations using similar equipment. The result of this method is that the total work of development resources is accounted for, independent of the linear metres of advance. Vertical development is all one profile, therefore equivalent and linear metres are equal.

16.2.10.2 Production Schedule

Table 16.17 shows the underground mine production schedule.

**TABLE 16.16
UNDERGROUND DEVELOPMENT SCHEDULE**

Units	Cost Type	Development Type	Underground Development Schedule by Year ¹										Total ²	
			2	3	4	5	6	7	8	9	10	11		
Linear Metres	CAPEX	Dewatering	60	121	39	42	18	0	35	15	20	0	350	
		Electrical	120	168	35	83	37	0	30	15	30	0	519	
		RV Loading Level	483	182	0	0	0	0	0	0	0	0	665	
		RV Adit	795	240	0	0	0	0	0	0	0	0	1,036	
		Broken Material Pass Accesses	0	252	197	272	357	42	65	34	27	0	1,246	
		Ventilation Accesses	0	166	266	121	257	51	81	18	10	0	971	
		Main Ramp	1,311	2,077	266	545	239	0	196	335	465	0	5,435	
		Level Accesses	0	240	179	176	93	0	58	30	30	0	806	
		Footwall Drifts	0	1,238	1,085	1,106	2,321	361	666	262	276	0	7,315	
		Re-muck Bays	0	115	210	72	33	0	15	15	45	0	504	
	OPEX	Mineralized OPEX Development	0	508	2,750	1,723	1,002	3,792	3,163	3,228	1,782	0	17,947	
		Waste OPEX Development	0	335	1,087	644	233	964	746	1,179	716	0	5,905	
	All	Total Lateral Linear m	2,770	5,643	6,113	4,785	4,589	5,210	5,055	5,132	3,401	0	42,697	
	CAPEX	Drop Raise – Ventilation	0	175	0	0	0	0	0	0	0	0	175	
		Alimak Raise – Ventilation	517	516	0	0	0	0	0	0	0	0	1,033	
		Alimak Raise – Broken Material Pass	443	658	886	0	0	0	0	0	0	0	1,988	
		All	Total Vertical Linear m	960	1,349	886	0	0	0	0	0	0	0	3,196
	Equivalent Metres	CAPEX	Dewatering	46	92	29	32	14	0	27	11	15	0	266
			Electrical	91	128	27	63	28	0	23	11	23	0	394
RV Loading Level			464	174	0	0	0	0	0	0	0	0	638	

TABLE 16.16
UNDERGROUND DEVELOPMENT SCHEDULE

Units	Cost Type	Development Type	Underground Development Schedule by Year ¹										Total ²
			2	3	4	5	6	7	8	9	10	11	
Equivalent Metres	CAPEX	RV Adit	605	183	0	0	0	0	0	0	0	0	787
		Broken Material Pass Accesses	0	191	150	207	271	32	49	26	21	0	947
		Ventilation Accesses	0	196	313	143	304	61	95	22	12	0	1,145
		Main Ramp	997	1,579	202	414	181	0	149	255	354	0	4,130
		Level Accesses	0	230	171	169	89	0	56	29	29	0	774
		Footwall Drifts	0	1,189	1,042	1,062	2,228	346	639	252	264	0	7,022
		Re-muck Bays	0	87	159	55	25	0	11	11	34	0	383
	OPEX	Mineralized OPEX Development	0	386	2,090	1,309	761	2,882	2,404	2,453	1,354	0	13,640
		Waste OPEX Development	0	254	826	490	177	733	567	896	544	0	4,487
	All	Total Lateral Eq m	2,202	4,690	5,010	3,944	4,078	4,054	4,020	3,966	2,650	0	34,615
		Average Eq m / d	6.1	13.0	13.9	11.0	11.3	11.3	11.2	11.0	7.4	0.0	11.2
	CAPEX	Drop Raise – Ventilation	0	175	0	0	0	0	0	0	0	0	175
		Alimak Raise – Ventilation	517	516	0	0	0	0	0	0	0	0	1,033
		Alimak Raise – Broken Material Passes	443	658	886	0	0	0	0	0	0	0	1,988
All	Total Vertical Eq m	960	1,349	886	0	0	0	0	0	0	0	3,196	

Note: ¹ Years are in relation to the Project production schedule that includes open pit mining.

² Totals may not sum due to rounding.

Eq m = equivalent metres, Eq m / d = equivalent metres per day.

TABLE 16.17
UNDERGROUND PRODUCTION SCHEDULE

Category	Units	Underground Production Schedule by Year ¹										Total ²
		2	3	4	5	6	7	8	9	10	11	
Mineralized Tonnes	kt	0	140	1,440	1,440	1,440	1,440	1,440	1,440	1,440	1,171	11,391
Contained Metal	koz	0	14	163	157	152	136	142	142	129	108	1,143
Gold Grade	g/t	0.00	3.02	3.51	3.39	3.27	2.95	3.06	3.07	2.79	2.88	3.12
Development Waste	km	176	341	326	246	230	255	251	256	174	0	2,256
Pastefill Volume ³	km ³	0	51	529	529	529	529	529	529	529	430	4,188
Tails Consumption	kt	0	69	715	715	715	715	715	715	715	581	5,653
Nominal Underground Daily Haulage Rate	tpd	488	1,337	4,906	4,682	4,639	4,709	4,698	4,712	4,484	3,252	4,397
Average Underground Power Draw	MW	1.8	3.5	4.1	3.8	3.6	3.4	3.7	3.5	3.6	1.7	3.5

Notes: ¹ Years are in relation to the Project production schedule that includes open pit mining.

² Totals may not sum due to rounding.

³ For clarity, units for pastefill volume are in thousand of cubic metres, not kilometres cubed.

16.2.10.3 Graphical Schedule

Figure 16.14 presents the historical and planned underground workings. Figures 16.15 to 16.18 show the underground advancement of development and production operations for the end of years 2, 4, 8 and mine life.

FIGURE 16.14 HISTORICAL AND PLANNED UNDERGROUND WORKINGS

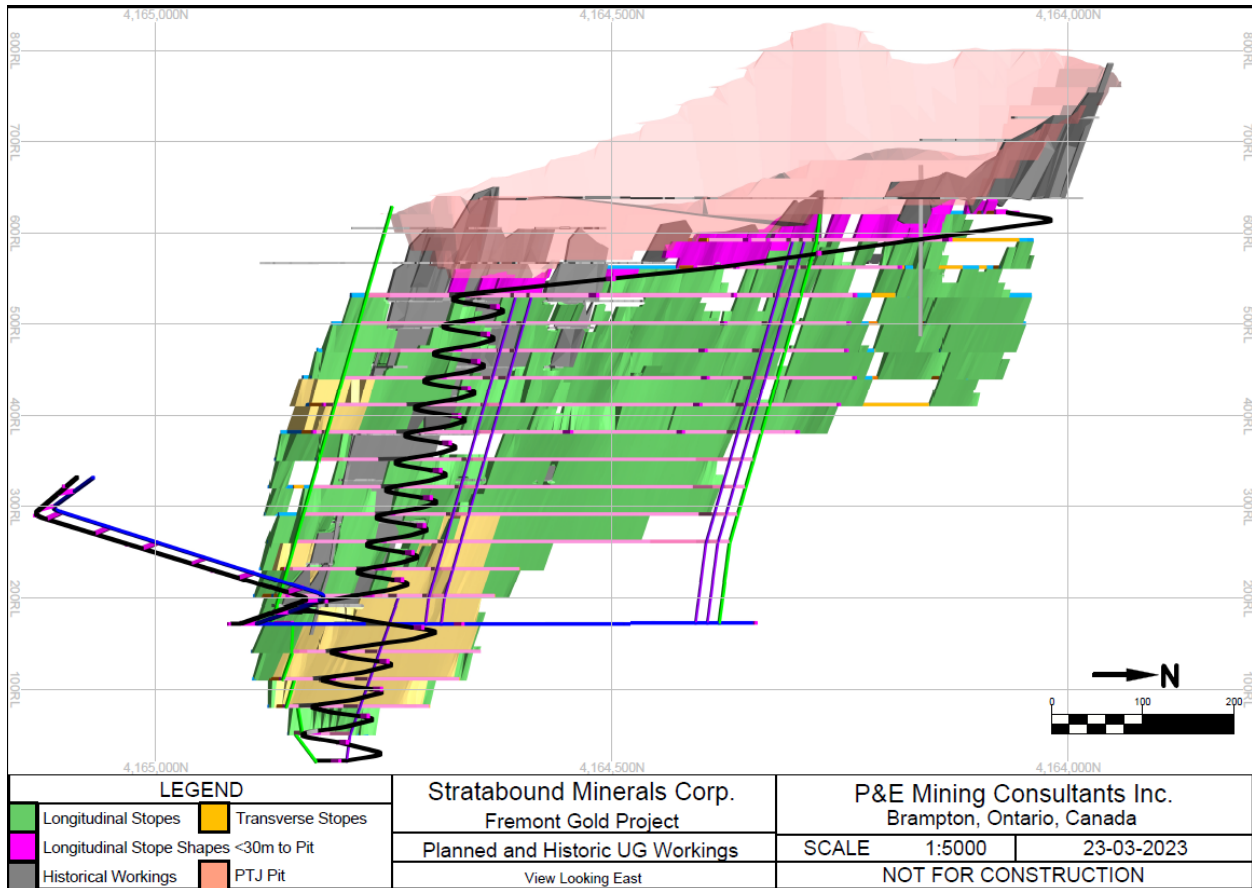

FIGURE 16.15 UNDERGROUND WORKINGS AS OF YEAR 2

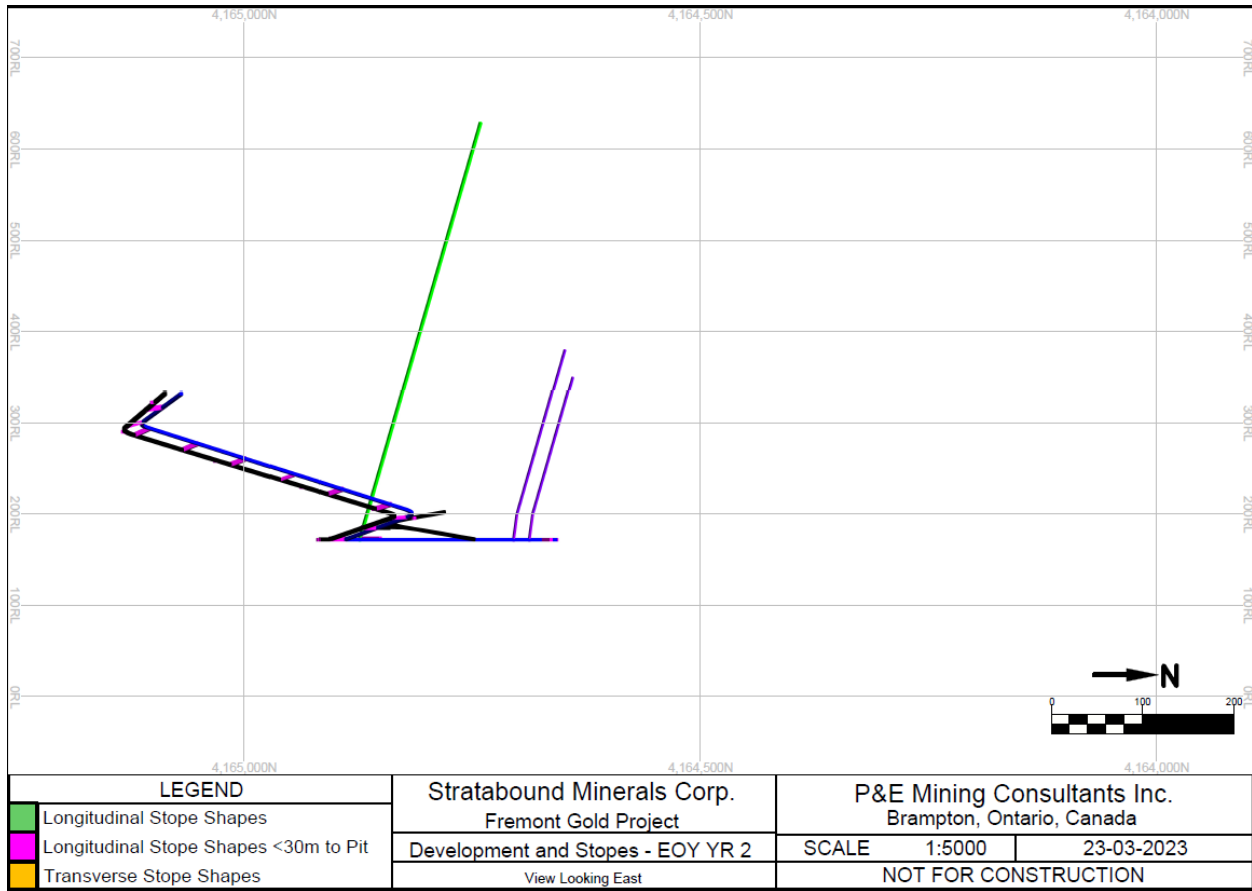

FIGURE 16.16 UNDERGROUND WORKINGS AS OF YEAR 4

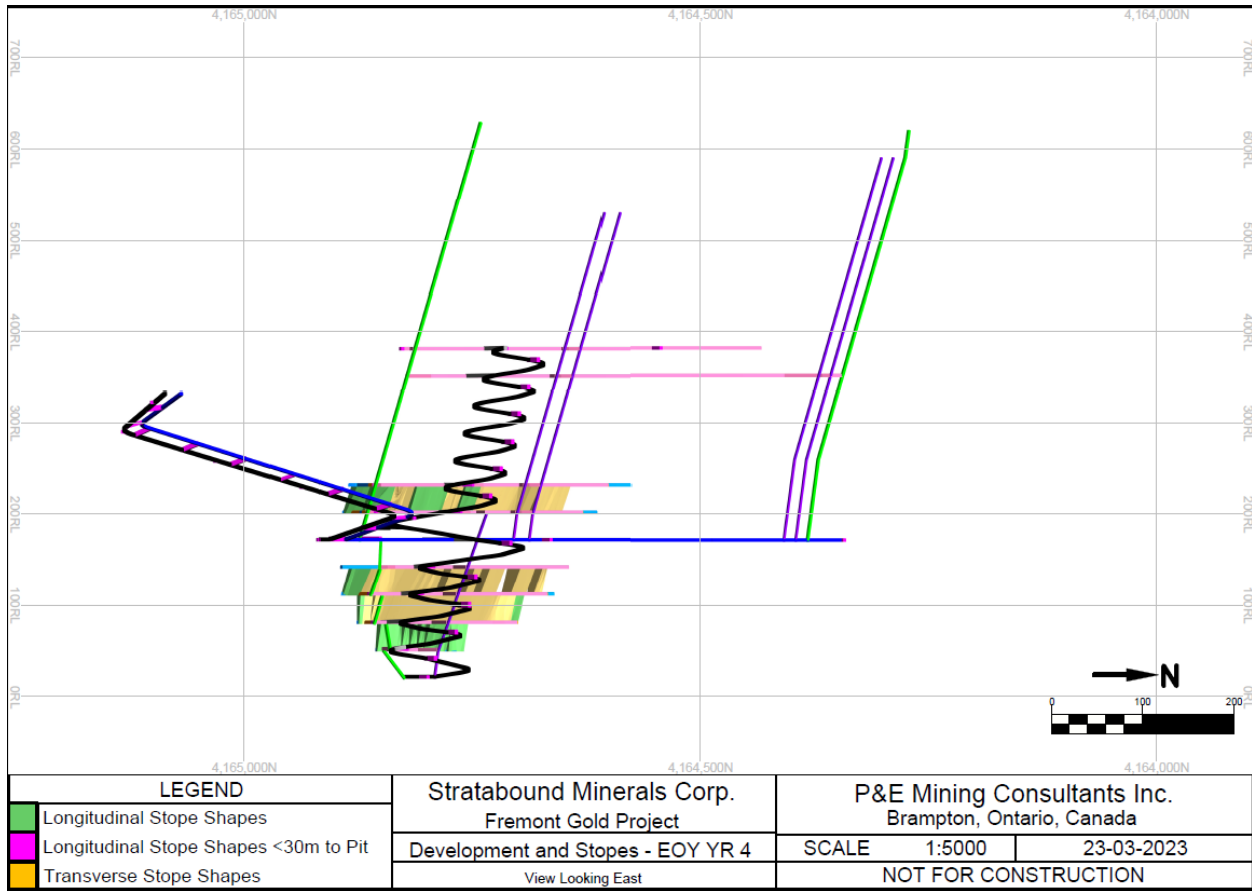

FIGURE 16.17 UNDERGROUND WORKINGS AS OF YEAR 8

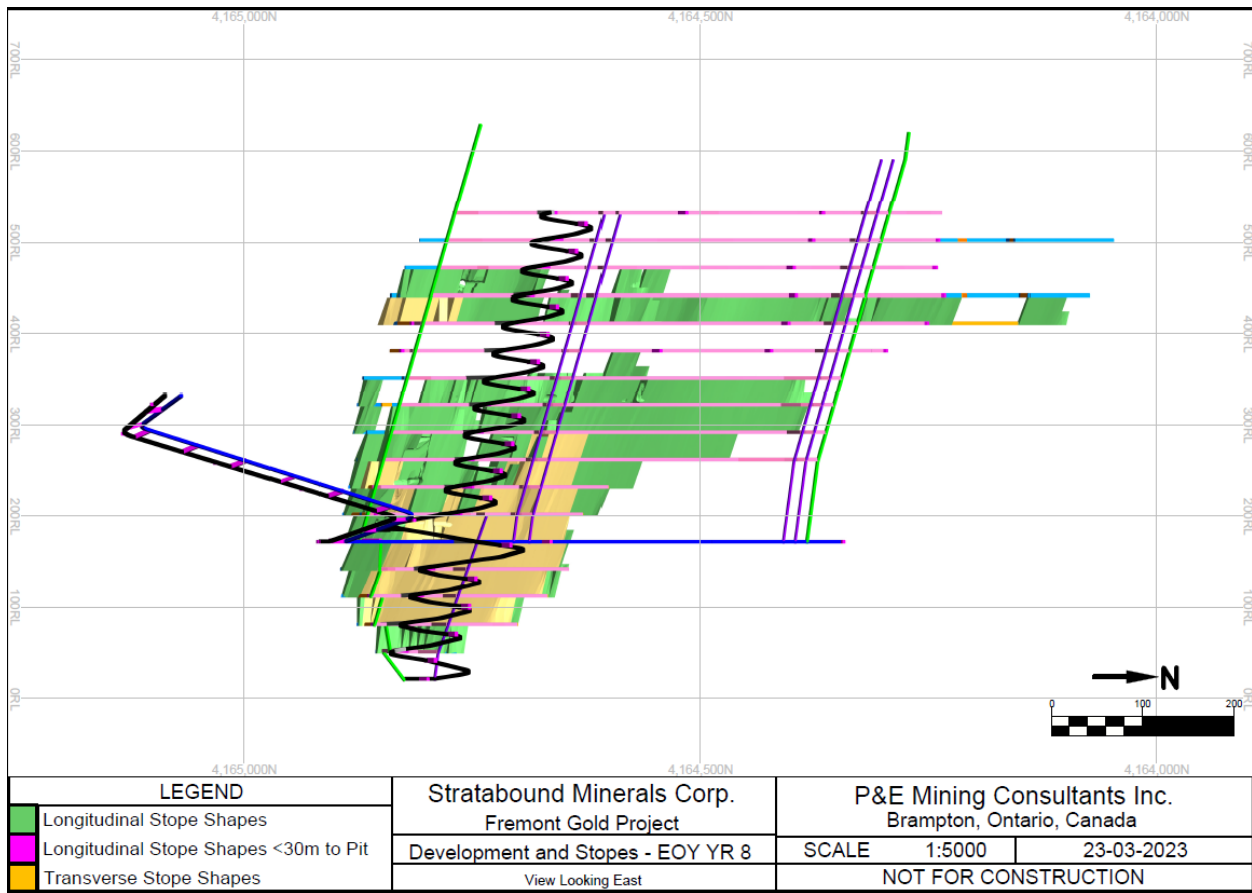
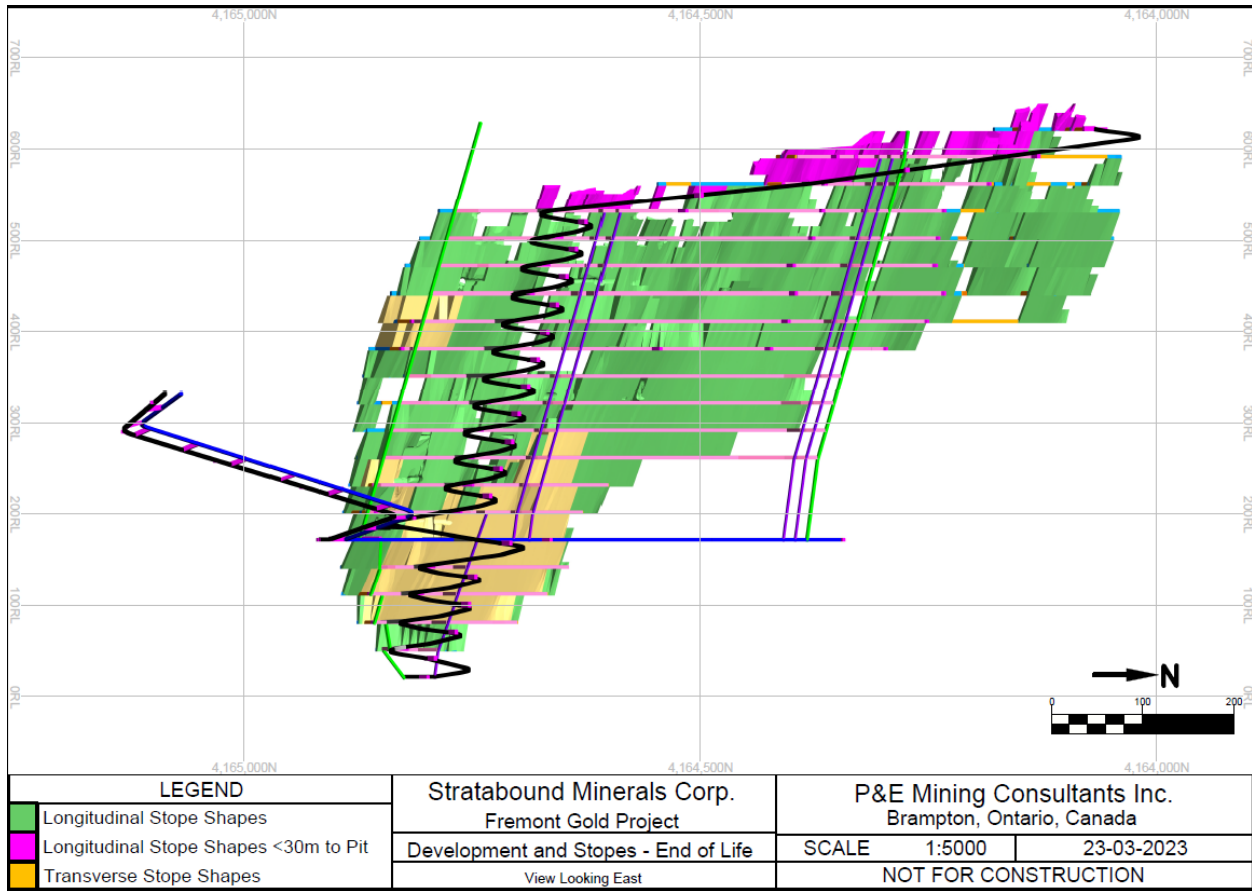

FIGURE 16.18 UNDERGROUND WORKINGS AT END OF LIFE



16.3 LIFE-OF-MINE PRODUCTION SCHEDULE

The LOM processing schedule will rely solely on mineralized material from the open pits for most of the first four years. In years 5 to 8, mineralized material will be delivered from both the underground mine and open pits. During years 8 and 9 the final years of processing will rely on underground mine operations and stockpiled low-grade mineralized material from the open pits. In years 10 and 11 mineralized material will come solely from underground mining.

Table 16.18 summarizes the LOM schedule.

TABLE 16.18
COMBINED MINING SCHEDULE (LIFE OF MINE)

Item	Unit	Total	-1	1	2	3	4	5	6	7	8	9	10	11
Open Pit														
Waste Rock	Mt	34.61	2.74	12.00	4.39	4.70	0.11	5.19	3.33	2.16				
Sulphide Mineralized Material	Mt	10.45	0.26	2.00	3.21	2.50	0.33	0.75	0.75	0.64				
Sulphide Au Grade	g/t	1.70	1.63	2.08	1.64	1.73	2.13	1.14	1.26	1.57				
Total Open Pit Material	t	45.58	3.07	14.44	7.60	7.20	0.45	5.94	4.08	2.80				
Strip Ratio	W:O	3.2	8.2	4.9	1.4	1.9	0.3	6.9	4.4	3.4				
Heap Leach Mineralized Material	Mt	0.51	0.07	0.44										
Oxide Au Grade	g/t	0.93	1.15	0.90										
Underground														
Total Mineralized Material	t	11.39				0.14	1.44	1.44	1.44	1.44	1.44	1.44	1.44	1.17
Au Grade	g/t	3.12				3.02	3.51	3.39	3.27	2.95	3.06	3.07	2.79	2.88
Combined OP & UG														
Total Mineralized Material	t	22.36	0.33	2.44	3.21	2.64	1.77	2.19	2.19	2.08	1.44	1.44	1.44	1.17
Au grade	g/t	2.40	1.53	1.87	1.64	1.80	3.25	2.62	2.58	2.53	3.06	3.07	2.79	2.88
Contained gold	koz	1,727.7	16.4	146.6	169.8	153.1	185.4	184.4	181.8	168.9	141.7	142.1	129.2	108.4

Note: OP = open pit, UG = underground.

17.0 RECOVERY METHODS

17.1 PROCESS DESCRIPTION SUMMARY

Metallurgical test work has indicated that the sulphide replacement mineralization (“SRM”) and quartz-hosted gold mineralization (“QTZ”) are not amenable to direct cyanidation and require an oxidation step to liberate the gold. The test work has indicated that the majority of the gold can be concentrated utilizing gravity and flotation concentration methods. Alternatively, metallurgical test work results to date have indicated that the oxide cap mineralization (“OCM”) material is amenable to heap leaching for the recovery of gold. The Fremont Project will be a 6,000 tonne per day flotation concentrator supported by a 1,500 tonne per day heap leach operation.

The transition and sulphide mineralized material are not amenable to heap leach technology and will be treated in a flotation concentrator. The material will be ground to 150 µm in a closed-circuit ball mill and the gold will be concentrated utilizing bulk sulphide flotation. The flotation concentrate will be filtered and will be toll processed at one of the regional process plants for roasting and cyanidation. The tailings from the process will be filtered and deposited in a lined facility.

The oxide cap of the mineralization will be treated by conventional heap leaching of crushed mineralized material stacked on a single use pad. Gold will be leached from the mineralized material with dilute cyanide solution and recovered from the solution using carbon adsorption. The gold-laden carbon will be shipped to an off-site processor for stripping and doré production.

The general arrangement for the process plant area is presented in Figure 17.1.

17.2 FLOTATION CONCENTRATOR

The primary mineralized material treatment at the Fremont Project will be through the flotation concentrator.

The flotation concentrator flowsheet is presented in Figures 17.2 and 17.3.

FIGURE 17.1 PROCESS PLANT AREA GENERAL ARRANGEMENT

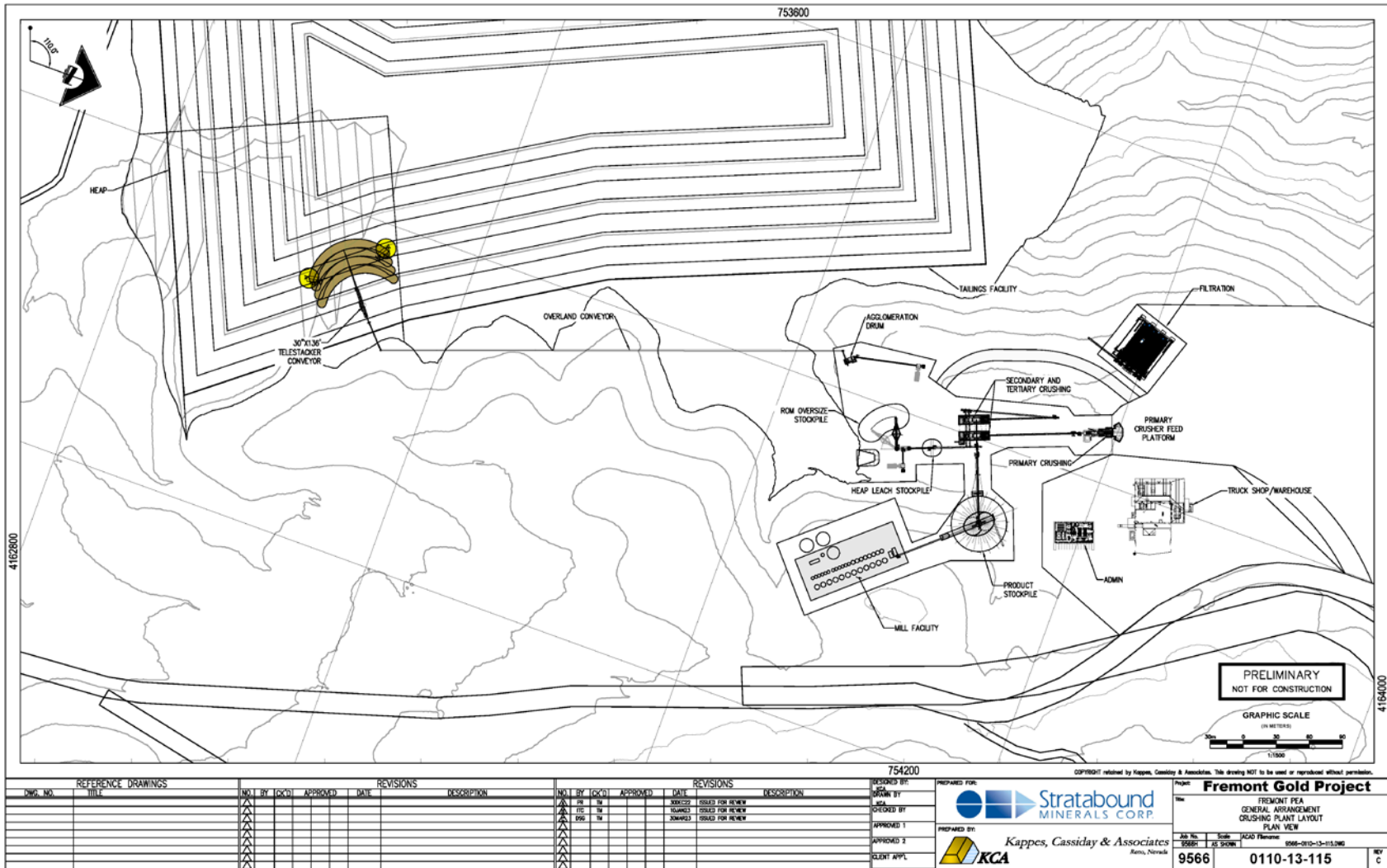

REFERENCE DRAWINGS				REVISIONS				REVISIONS				DESIGNED BY		PREPARED FOR		PROJECT		
DRG. NO.	TITLE	NO.	BY (DC)	APPROVED	DATE	DESCRIPTION	NO.	BY (DC)	APPROVED	DATE	DESCRIPTION	NAME	DATE	SCALE	JACO FINISH	DATE	REV	
		1	TR				1	TR		2023-02-22	ISSUED FOR REVIEW	Stratabound Minerals Corp.	2023-02-22	AS SHOWN	0966-010-13-115.066			
		2	TR				2	TR		2023-02-22	ISSUED FOR REVIEW	Kappes, Cassidy & Associates	2023-02-22			9566	0110-13-115	C
		3	TR				3	TR		2023-02-22	ISSUED FOR REVIEW							
		4	TR				4	TR		2023-02-22	ISSUED FOR REVIEW							
		5	TR				5	TR		2023-02-22	ISSUED FOR REVIEW							

Source: KCA (2023)

FIGURE 17.2 FLOTATION CONCENTRATOR FLOWSHEET 1

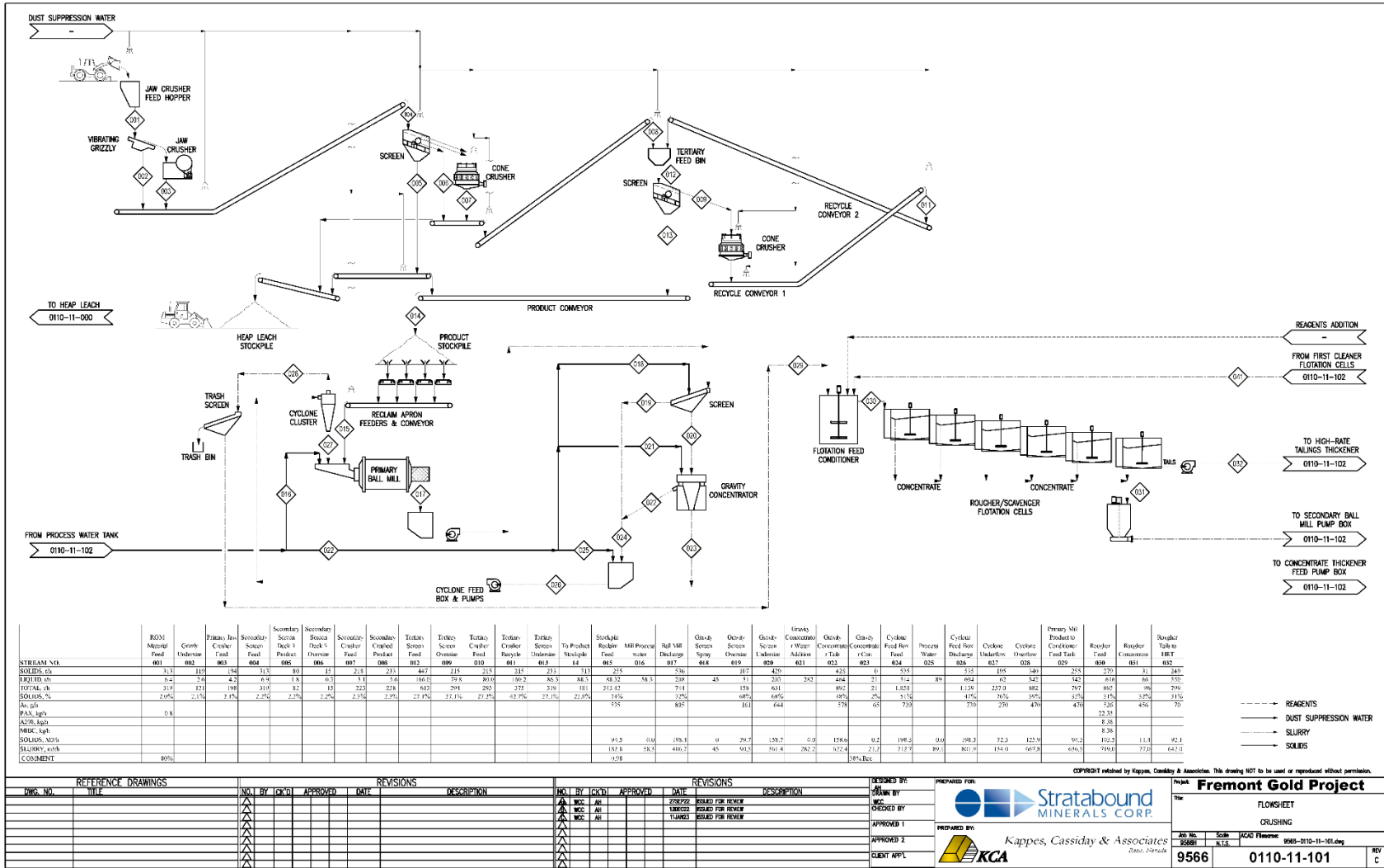

Source: KCA (2023)

Copyright retained by Kappes, Cassidy & Associates. This drawing NOT to be used or reproduced without permission.

Project: **Fremont Gold Project**

Client: **Stratabound Minerals Corp.**

Engineer: **Kappes, Cassidy & Associates**

Job No: **9566** Scale: **KCAU Flowsheet** Date: **09/08-01/10-11-01.dwg**

Sheet: **9566** Title: **0110-11-101** Rev: **C**

FIGURE 17.3 FLOTATION CONCENTRATOR FLOWSHEET 2

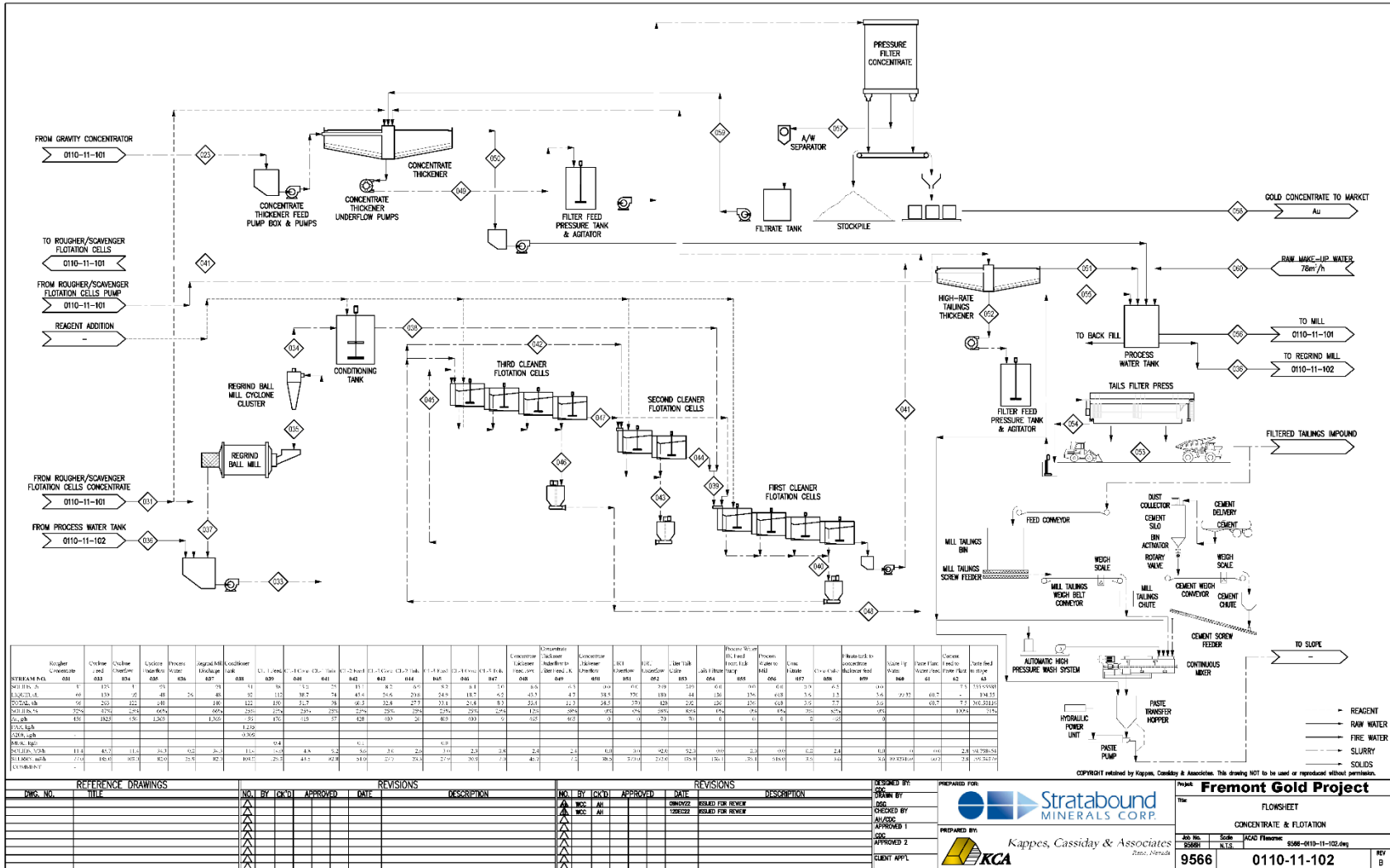

Stream No.	Flow Rate (t/hr)	Grade (%)	Component 1 (%)	Component 2 (%)	Component 3 (%)	Component 4 (%)	Component 5 (%)	Component 6 (%)	Component 7 (%)	Component 8 (%)	Component 9 (%)	Component 10 (%)	Component 11 (%)	Component 12 (%)	Component 13 (%)	Component 14 (%)	Component 15 (%)	Component 16 (%)	Component 17 (%)	Component 18 (%)	Component 19 (%)	Component 20 (%)	Component 21 (%)	Component 22 (%)	Component 23 (%)	Component 24 (%)	Component 25 (%)	Component 26 (%)	Component 27 (%)	Component 28 (%)	Component 29 (%)	Component 30 (%)		
010-11-101	100	10.0	10.0	0.0	0.0	0.0	0.0	0.0	0.0	0.0	0.0	0.0	0.0	0.0	0.0	0.0	0.0	0.0	0.0	0.0	0.0	0.0	0.0	0.0	0.0	0.0	0.0	0.0	0.0	0.0	0.0	0.0	0.0	
010-11-102	100	10.0	10.0	0.0	0.0	0.0	0.0	0.0	0.0	0.0	0.0	0.0	0.0	0.0	0.0	0.0	0.0	0.0	0.0	0.0	0.0	0.0	0.0	0.0	0.0	0.0	0.0	0.0	0.0	0.0	0.0	0.0	0.0	0.0

REF. NO.	REFERENCE DRAWINGS	NO. BY	CHKD	APPROVED	DATE	DESCRIPTION	NO. BY	CHKD	APPROVED	DATE	DESCRIPTION

DESIGNED BY	PREPARED FOR	PROJECT
JSC	Stratabound Minerals Corp.	Fremont Gold Project

APPROVED 1	APPROVED 2	CLIENT APPL.
JSC	KCA	

JOB NO.	SCALE	DATE	REV
9566	N.E.S.	05/08-01/11-102.dwg	B

Source: KCA (2023)

17.2.1 Process Design Criteria

Preliminary engineering and design of the process plant was undertaken by Kappes, Cassiday & Associates (“KCA”) for crushing, grinding, gravity concentration, flotation, concentrate filtration, tailings filtration and tailings paste backfill. The criteria used for the design of this circuit are summarized in Table 17.1.

Annual Tonnage Processed	2.19Mt
Concentration Operation	12 hours/shift, 2 shift/day, 7 days/week
Crushing Production Rate	313 t/h
Grinding Production Rate	255 t/h
Primary Grinding Product Size	80% -149 microns (100 mesh)
Gravity Concentration Type	Centrifugal Concentrator
Rougher/Scavenger Flotation Retention Time	23 minutes
Regrind Grinding Product Size	80% -37 microns (400 mesh)
First Cleaner Flotation Retention Time	29 minutes
Second Cleaner Flotation Retention Time	29 minutes
Third Cleaner Flotation Retention Time	29 minutes
SRM Gold Recovery to Concentrate	85.6%
QTZ Gold Recovery to Concentrate	93.6%

Combined gravity and flotation gold recovery for the sulphide mineralization is estimated at 90% based on historical operation and test work.

17.2.2 Process Description

17.2.2.1 Crushing

Run-of-mine mineralization will be delivered by haul trucks from the open pit or by a Railveyor™ system from the underground mine to the primary crusher pad area. As much as possible, material will be direct-dumped by haul trucks into the primary crusher dump hopper. Mineralization will also be reclaimed from stockpiles by a front-end loader into the dump hopper located above the apron feeder as required for either blending or haul truck availability.

A stationary grizzly over the dump hopper will be included to prevent oversized material (+500 mm) from plugging the feeder. A rock breaker will be used to break up any oversized material. An apron feeder will deliver the run-of-mine mineralized material to a vibrating grizzly. The grizzly oversize will be crushed utilizing the primary jaw crusher. The jaw crusher product will combine with the grizzly undersize and discharge to the primary crusher discharge conveyor which feeds the secondary screen.

The secondary screen is a multi-deck screen that will separate the primary crushed product into oversize, middlings and undersize. Undersized material passes the desired product of the system and is fed to the crushed stockpile. Middlings bypass the secondary crusher while oversize will be crushed in the secondary cone crusher. The secondary cone crusher product and screen middlings will discharge to the secondary crusher discharge conveyor, which feeds the tertiary screen.

An estimated 25% of the heap leach material will need to be crushed. This portion will be campaigned through the process plant crusher, utilizing the primary and secondary circuits. The discharge secondary screen undersize and secondary cone crusher product conveyors are reversible. When reversed, these conveyors feed the heap leach stockpile conveyor.

The tertiary screen oversize will be crushed in the tertiary cone crusher. Cone crusher product is returned to the tertiary screen. The tertiary screen undersize will discharge onto the product conveyor which will feed the crushed stockpile.

17.2.3 Crushed Stockpile and Reclamation

The crushed stockpile is filled by the crushed stockpile stacker. The stockpile will be constructed over a subterranean tunnel containing reclaim belt feeders and the reclaim tunnel conveyor.

17.2.4 Grinding and Gravity Separation

The ball mill discharge is transferred to a vibrating screen, sending material that is too large for the gravity concentrator to a sump and the remaining undersize to a centrifugal gravity concentrator. The tailings from the gravity concentrator combines with the screen oversize in a sump and is pumped to hydrocyclones for size separation. The gravity concentrate is transferred to the concentrate thickener for dewatering. The hydrocyclone closes the grinding circuit sending the oversize back to the ball mill and the undersize to a trash screen to prepare it for flotation.

17.2.5 Flotation and Re grind

The cyclone overflow feeds the conditioning tank for the rougher and scavenger circuit. The frother (Methyl Isobutyl Carbinol (“MIBC”)), promotor Aero 208, and collector (potassium amyl xanthate (“PAX”)) are added to the conditioning tank. The concentrates from the rougher and cleaner flotation cells are combined and transferred to the regrind ball mill discharge sump. The tailings from the scavenger cells are transferred to the tailings thickener for preliminary dewatering.

The combined regrind ball mill discharge and rougher/scavenger flotation concentrate are pumped from the ball mill discharge sump to a cluster of hydrocyclones. The cyclone oversize feeds the regrind ball mill while the undersize is transferred to the conditioning tank for the cleaner flotation circuit.

Additional MIBC, Aero 208 and PAX are added to the conditioning tank for the cleaner flotation circuit. The conditioned material is transferred to the first of three stages of cleaner concentration flotation cells. The concentrate from the 1st cleaner flotation cells is fed to the 2nd cleaner flotation

cells while the tailings from the 1st cleaner flotation cells are recycled to the rougher/scavenger conditioning tank. The concentrate from the 2nd cleaner flotation cells is fed to the 3rd cleaner flotation cells while the tailings from the 2nd cleaner flotation cells are recycled to the 1st cleaner flotation cells. The concentrate from the 3rd cleaner flotation cells is transferred to the concentrate thickener while the 3rd cleaner tailings are recycled to the 2nd cleaner flotation cells.

17.2.6 Concentrate Dewatering

The combined flotation and gravity concentrates are pumped from the underflow of the concentrate thickener to the agitated filter feed tank. The concentrate thickener overflow water is transferred to the process water tank for reuse in the process plant. The concentrate is then pumped to a vertical plate and frame filter for final dewatering. The filtered concentrate discharges onto a reversible belt where it can either be fed to a stockpile or loaded into bulk bags. The filtrate is returned to the concentrate thickener.

17.2.7 Tailings

The tailings are pumped from the tailings thickener underflow to the agitated filter feed tank. Overflow solution from the tailings thickener will be transferred to the process water tank for use in the process. The tailings are then pumped to a horizontal plate and frame filter for final dewatering. The presses will operate in a cycle consisting of filter closing and clamping, filter feed, core wash and core blow, membrane squeeze of the filter cake, cake discharge and finally cloth washing. The wash water is used for core washing and for cloth washing prior to beginning a new filtration cycle. Filtrate is collected in the thickener overflow/filtrate tank and pumped back to the process plant. After completion of the filtration cycle, the cake will discharge onto a cake discharge conveyor where it can be sent to the tailings storage facility or fed to the paste backfill plant. There is a conveyor system to transport the tailings to the dry stacked tailings storage facility to a radial stacker for discharge of the filtered tailings into a lined tailings storage facility. The tailings will be spread out and compacted in short lifts for stability and to minimize water absorption.

17.2.8 Paste Backfill

There will be times when the tailings are used to backfill the underground mine. During these times, the filtered tailings will be transferred to a tailings bin. A screw feeder in the bin will deliver the tailings to the tailings weigh belt conveyor which discharges into a continuous paste mixer. A screw feeder will deliver cement from a silo into the continuous paste mixer in proportion to the tailings. The continuous mixer adds appropriate water, mixes and discharges the paste into a transfer hopper. A paste pump takes the paste from the hopper and pumps it to a stope for backfilling the underground mine.

17.3 HEAP LEACH

The Pine Tree-Josephine Deposit has an oxide cap that is amenable to heap leach processing. The 0.5 Mt of oxide cap will be processed in a heap leach during the first year of operation at a rate of 1,500 tonnes per day. The heap leach flowsheet is presented in Figure 17.4.

17.3.1 Process Design Criteria

Preliminary engineering and design of the heap leach facility was undertaken by KCA. The criteria used for the design of this circuit are summarized in Table 17.2.

Annual Tonnage Processed	0.55 Mt
Stacking & Leaching Operations	12 hours/shift, 2 shift/day, 7 days/week
Nominal Stacking Rate	1,500 t/d
Screening Plant	75% -50 mm
Crushing Operations	+50 mm campaigned through concentrate crusher
Crushed Product Size	80% - 28 mm
Leach Cycle	90 days
Solution Application Rate	10 L/h/m ²
Nominal Adsorption Treatment Flow	96 m ³ /h
Gold Recovery	82%

17.3.2 Process Description

17.3.2.1 Screening and Crushing

The oxide cap is weathered and Stratabound estimates that 75% of the material meets the desired leach size of 100% passing 50 mm. To minimize the load on the crusher, a portable screening plant will be utilized to separate the oversize for additional crushing. The screening plant discharges into an oversize stockpile and an undersize stockpile. The oversized material from the screening plant will be campaigned through the crusher. The oversize is fed to the crusher by loader. When crushing the heap leach mineralized material, the crusher will discharge into the undersize stockpile from the screening plant.

17.3.2.2 Agglomeration, Conveying and Stacking

A front-end loader will collect material from the combined screen undersize and crushed mineralized material stockpile and feed it into a hopper. A belt feeder in the hopper will convey the mineralized material to an agglomeration drum. Cement will be added to the belt feeding the agglomeration drum, where the mineralized material will be gently tumbled and sprayed with water to form agglomerates.

The heap will be constructed in 10 m high lifts, using a mobile conveyor stacking system. The system will consist of mobile field conveyors (grasshoppers) that transfer the material from the agglomeration discharge conveyor in the crusher area to a horizontal index conveyor and mobile stacker conveyor. The mobile stacker will pivot in a semi-circular arrangement. Stacking will be done in a retreating fashion, starting near the pregnant solution pond and retreating upslope. The

grasshopper conveyors will be repositioned as necessary once each stacking line/strip has been completed.

Once the designated area has been stacked and leached over the first lift, a second lift will be stacked over the first in a similar retreating fashion, using the appropriate lift setback for overall heap stability. Grasshopper conveyors will be used to convey material up the lifts as necessary into the live stacking area. Additional lifts will be constructed in similar fashion.

17.3.2.3 Leach Pad

The preliminary design of the Heap Leach facility (“HLF”) meets or exceeds North American standards and practices for containment, piping systems, and ponds, which is intended to lessen the environmental risk of the facilities to impact the local soils, surface water, and ground water in and around the site.

HLFs are intended to operate as zero discharge systems; therefore, they include provisions to accommodate upset conditions such as severe storms and temporary loss of electric power or pumps.

The HLF will have the following features:

- Will have a composite base liner that meets or exceeds international standards consisting of (from the base up) 0.3 m of compacted low permeability soil, a 2.0 mm thick double sided textured high density polyethylene (“HDPE”) geomembrane around the perimeter of the HLF from the edge of liner to 50 m into the pad and 2.0 mm thick smooth HDPE geomembrane elsewhere on the pad, and a 0.5 m thick drainage layer of crushed agglomerated mineralization or mine waste rock.
- Mineralized material will be stacked in nominal 10 m lifts using conveyors starting from the lower elevations of the leach pad. Benches will be provided between lifts to provide an overall heap slope of 3 H:1 V.
- Solution will be collected above the leach pad geomembrane (2.0 mm HDPE, or 1 mm linear low-density polyethylene (“LLDPE”)) and delivered to the Pregnant Pond using a drainage pipe system placed above the geomembrane within the 0.5 m drainage layer.
- During normal operation, pregnant solution will be removed from the Pregnant Pond to an adsorption facility. During upset conditions, water will overflow by gravity from the Pregnant Pond to Event Ponds.

17.3.2.4 Leaching Systems

A total leach time of 90 days has been designed for the heap leach system, which is based upon preliminary metallurgical test work with the appropriate field adjustments made, as described in

Section 13. Leach solutions will be applied to the oxide material at a nominal application rate of 10 L/h/m².

Pumps at the barren tank will be used for barren solution application to the heap leach. These pumps will be mounted beside the barren tank to provide the necessary flow and head to irrigate the heap leach pad up to its ultimate height and size. High-strength cyanide and an anti-scalant agent will be added to the suction side of the barren leach solution pumps by metering pumps.

A steel header pipe from the barren tank pumps will supply the solution to the active irrigation areas on the leach pad. Valved tees at the header will supply leach solution to risers that distribute solution to the top of the stacks at the active leach cells.

Gold-bearing solutions draining from the leach pad are collected at the bottom of the stack by a network of perforated drainage pipes within a gravel layer and are directed to the pregnant pond.

Installed submersible pumps in the ponds are used for solution transfer. The pumps are mounted on slides on the pond sidewalls to facilitate placement and extraction of the pumps in the ponds. Additional rough-textured protective liner panels and conveyor belting are installed on the pond sidewalls in the area where the pumps are located to protect the pond liner.

17.3.2.5 Solution Collection System

During leaching, solution will be collected above the composite liner system by a network of perforated collection pipes within the drainage layer liner cover material and diverted to a low point constructed at the separation berms within each solution collection cell.

The drainage layer overliner material will be free-drained crushed durable gravel with a target permeability of approximately 1×10^{-1} cm/sec and placed on the pad liner in a 0.5 m thick layer.

17.3.2.6 Adsorption

Pregnant solution will be pumped from the pond to the up-flow, open-top, carbon steel adsorption columns. Magnetic flow meters with totalizers and wire samplers for continuous sampling of the pregnant solution will be installed.

Pregnant solution will continue to flow through the columns until the gold concentration of the barren solution exiting a train exceeds the desired limits. The carbon will then be pumped to the bagging circuit. Carbon will then be sequentially moved up the adsorption train counter-currently to the solution flow from column 5 to column 1. New or stripped carbon will be pumped into column 5. All carbon transfer will be achieved using recessed impeller or screw-type pumps to minimize carbon attrition.

Barren solutions from the last carbon columns will be continuously sampled by wire samplers for metallurgical accounting then discharged to the carbon safety screens to recover floating fugitive carbon. Any fugitive carbon will be collected and recovered into tote bins. The solution discharge from the screens will flow by gravity to the barren advance tanks. Barren advance pumps will deliver barren solution to the barren solution tank.

The gold laden carbon will be bagged in supersacks and shipped to a carbon stripping facility for further treatment.

17.4 REAGENTS

17.4.1 Potassium Amyl Xanthate (PAX)

PAX will be used as a collector for the sulphide minerals containing the gold. The PAX will be metered into the conditioning tanks in proportion to the processing rate of the flotation circuit.

The PAX consumption for the flotation circuit is estimated at 120 g/t.

17.4.2 Aero 208

Aero 208 will be used as a promotor for the flotation of the gold-containing minerals. The Aero 208 will be added to the conditioning tanks in proportion to the processing rate of the flotation circuit.

The Aero 208 consumption for the flotation circuit is estimated at 40 g/t.

17.4.3 Methyl Isobutyl Carbinol (MIBC)

MIBC will be used as a frother for the flotation circuit. The MIBC will be metered into the conditioning tanks in proportion to the processing rate of the flotation circuit.

The MIBC consumption is estimated at 49 g/t of material processed.

17.4.4 Sodium Cyanide

The sodium cyanide make-up and addition will be comprised of a sodium cyanide mix system. The system is designed for dry sodium cyanide delivery in ISO-containers. The system will consist of a cyanide mix tank, recirculation/transfer pump and a cyanide storage tank. The cyanide mix system is designed to produce a 20% cyanide solution. From the cyanide storage tank, metering pumps will be used to add controlled quantities of cyanide solution to the heap leach barren solution pumps.

Sodium cyanide usage is estimated to average 0.51 kg/tonne.

17.4.5 Cement

Cement will be used for agglomeration and to control pH in the heap leach system. Cement will be metered from a silo by a screw feeder onto the heap leach agglomeration feed conveyor in proportion to the rate of mineralized material being conveyed and the desired dosage per tonne.

Cement will also be used to strengthen the tailings when they are processed in the paste plant to backfill the underground mine.

Cement usage for the heap is estimated to average 3.5 kg/tonne of material processed.

17.5 WATER

Water runoff from upstream of the developed Property will be diverted around the mine operations and allowed to return to natural drainage locations. Ditches around ponds, stockpiles, buildings and roads will collect water from developed portions of the Property which will be directed to small sedimentation settling ponds to allow the turbidity to clear before discharge to natural drainage locations.

Estimates of average monthly precipitation were based on the Central California NWS COOP Network. The evaporation rates were based on information from the California Irrigation Management System. The monthly rainfall and evaporation data are summarized in Table 17.3.

Water	Jan	Feb	Mar	Apr	May	Jun	Jul	Aug	Sep	Oct	Nov	Dec	Annual
Average Precipitation	152	138	117	66	22	7	1	1	11	38	85	125	763
Pan Evaporation	39	57	79	114	150	183	205	189	145	94	53	39	1,347

The 100-year, 24-hour storm event was taken into account and is from the NOAA Point Precipitation Frequency Estimates at 190 mm.

KCA prepared preliminary water balances for the proposed tailings facility, the heap leach, as well as the process plant. The model for the tailings facility approximates the circulation of solutions within the process facility, as well as the introduction of precipitation and evaporation as a function of time. The results of the water balance model predict the make-up water and discharge water flow rates and minimum storage capacities required.

The facility estimated water balance is presented in Figure 17.5.

The mine is expected to need approximately 170 litres per minute in the open pit and 170 litres per minute in the underground, and the process plant requires 607 litres per minute, giving a total average site requirement of 947 litres per minute of water. This works out to approximately 498,000 m³ of makeup water per year.

FIGURE 17.5 WATER BALANCE

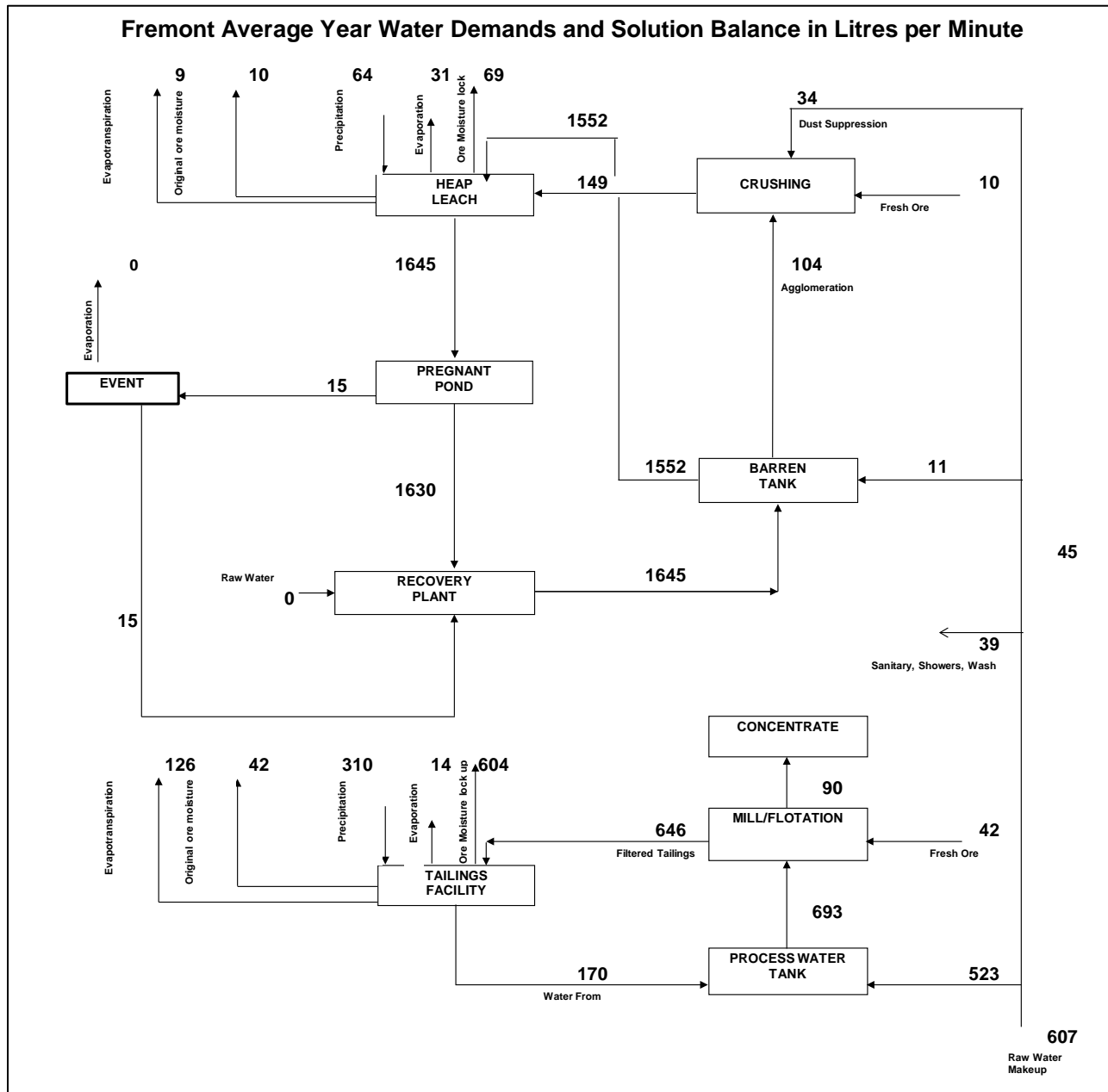

18.0 PROJECT INFRASTRUCTURE

18.1 INFRASTRUCTURE

The infrastructure for the Fremont Project has been developed to support a mining, processing, and heap leaching operation. This includes the access road to the Project site, power supply, communication, heap leach pad, process plant, and ancillary buildings. Water supply to the site, including tanks, pipelines, ponds, and diversions, are described in Section 18.3. Haul roads within the mining area and the mine waste rock storage facility are described in Section 16. The Leach Pad and Process/Event Pond are discussed in Section 17.

18.1.1 Existing Installations

California State Highway 49 bisects the Property from north to south and numerous private dirt roads provide access for mineral exploration and cattle grazing. A 70 kV power transmission line owned by PG&E traverses the Property from east to west. The local Bear Valley substation is located adjacent to Fremont Gold Mining LLC's office-warehouse, along Highway 49.

18.1.2 Access and Site Roads

The Fremont Property is readily accessible by California State Highway 49, Figure 18.1. The Property is located mid-way between the Towns of Mariposa and Coulterville. The Town of Mariposa is located 12.6 miles (20.3 km) south of the Property and is the nearest community with major infrastructure.

A bypass of Highway 49 will be constructed to avoid the pit area. The highway will be moved approximately 0.25 km to the west of the Pine Tree-Josephine Pit. The current site access road will be used, and moderate upgrades will be done to the surface and width of the road to allow for safe vehicle traffic on the road. The site roads will be constructed or upgraded to an operating surface width of 10 m. Magnesium Chloride ("MgCl") or equivalent will be applied as needed to the access roads for dust control.

FIGURE 18.1 FREMONT PROJECT SITE LAYOUT

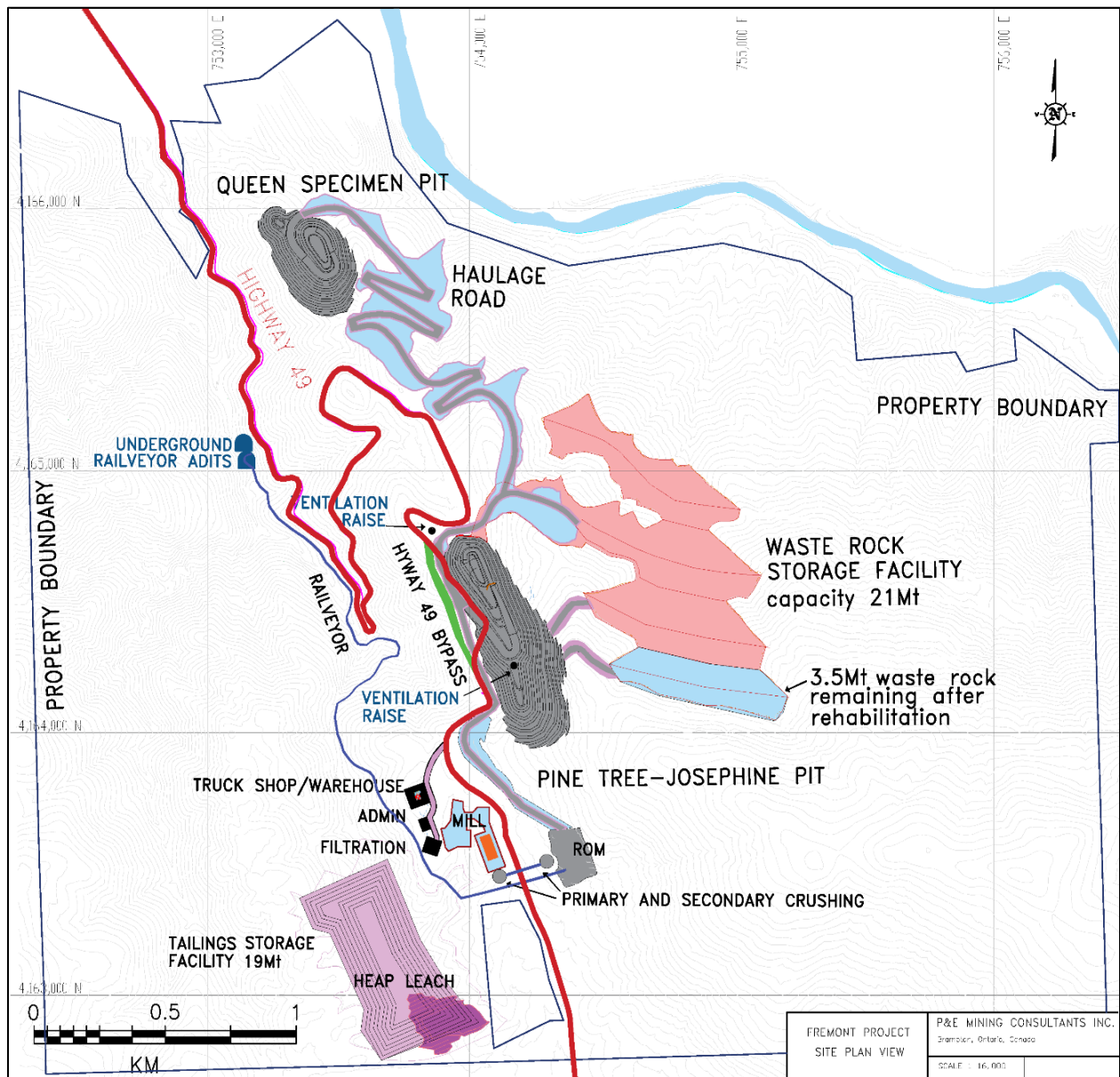

18.1.3 Project Buildings

Buildings on the proposed mine site will include a site security building, administrative offices, a mobile equipment maintenance shop, a warehouse, process plant buildings and a laboratory.

The site security building will be located at the exit from the highway to the Project site. The security building includes an entry access gate that will control all site ingress-egress. A security fence will surround the active mine and facilities from the entry gate.

The administration building will be a double- or triple-wide office trailer with sufficient room for up to eight offices, one conference room, and a first aid clinic. A second trailer will be used for

mine operations to house the mining supervision, engineering, and geology departments. A third trailer will be used for safety and training facilities. Each building will be in service with electricity, water, and leach field sewage.

The mobile equipment maintenance shop located near the process plant will include service bays to support equipment maintenance. Lubricants and coolants will be managed and stored in the area as required by MSHA and other state and federal regulations. A mobile equipment wash facility will be located adjacent to the maintenance shop. Wash water will be directed to a settling basin where water and solids will be separated. Water will be treated with an oil-water separator and re-circulated.

18.1.4 Warehouse

The warehouse for the process area will be located in the same building as the mobile equipment maintenance shop.

18.1.5 Laboratory

A laboratory facility will be constructed near the process plant and will process samples from the mine and process facilities. The lab will include a wet lab, atomic adsorption, and fire assay capability with the capacity to process up to 150 samples per day.

18.1.6 Fuel Storage and Dispensing

A fuel storage depot will be located near the mobile equipment maintenance shop. It will include separate diesel aboveground tanks for fuelling light/intermediate and heavy vehicles as well as aboveground gasoline storage tanks. Spill containment will be designed for 110 percent of the largest tank or tanker within the containment. A sump will be located at one end of the containment so that spilled fuels can be pumped from the containment using a portable pump for appropriate disposal.

18.1.7 Explosives Storage

Explosive agents will be purchased, transported, stored, and used in accordance with the Bureau of Alcohol, Tobacco, and Firearms, Department of Homeland Security provisions, MSHA regulations, and other applicable federal, state, or local legal requirements. The primary explosive used will be ANFO. Ammonium nitrate prill will be stored in a silo in a secure area and other explosive agents, boosters, and blasting caps will be stored in magazines within a separate secured area near the east waste rock storage facility.

18.2 ELECTRICAL POWER SUPPLY

18.2.1 Process Plant and Heap Leach Electrical Power Supply

There is currently an existing substation at the Project site. The on-site substation is assumed to be able to provide sufficient power for the operation. A 70 kV power transmission line owned by PG&E traverses the Property from east to west. The local Bear Valley substation is located adjacent to Fremont Gold Mining LLC's office warehouse along Highway 49.

Power requirements are separated into Heap Leach power requirements and Process Plant power requirements. The heap leach operation will only occur in Year 1 of operation. Years 2 to LOM will include the process plant and underground mine power requirements.

The estimated attached power for the process plant, which includes the water supply system, crushing system, milling, flotation concentration, including the reagents area, and ancillary equipment at the Fremont mine site, is 10.3 MW with an average demand of 7.6 MW. The estimated process plant electrical power consumption by project area is depicted in Table 18.1.

Area/Description	Total Connected Load (kW)	kWh/t Mineralized Material	Average Demand, (kW)
Area 0113 - Crushing	1,180.16	2.28	663.84
Area 0116 - Grinding	3,553.20	10.68	3,115.42
Area 0117 - Gravity Concentration	222.31	0.74	215.64
Area 0121 - Flotation	2,077.61	5.18	1,511.46
Area 0470 - Tails Thickening, Filtration and Stacking	2,171.67	5.85	1,707.29
Area 0270 - Tailings Paste Backfill	655.02	0.67	196.51
Area 0130 - Concentrate Handling	76.38	0.19	55.56
Area 0134 - Reagents	20.00	0.05	14.55
Area 0160 - Process Emergency Power	10.00	0.01	5.63
Area 0162 - Water Supply & Distribution	223.86	0.43	125.92
Area 0366 - Facilities	70.00	0.14	39.38
Total	10,260.19	26.22	7,651.19

The estimated connected load for the heap leach, which includes a water supply system, shared crushing system, screening system, Carbon-in-Column facility, including the reagents area, and ancillary equipment at the Fremont mine site is 1.6 MW and an average demand of 0.9 MW. The estimated Heap Leach electrical power consumption by project area is depicted in Table 18.2.

TABLE 18.2
HEAP LEACH POWER REQUIREMENTS

Area/Description	Total Connected Load (kW)	kWh/t Mineralized Material	Average Demand, (kW)
Area 113 - Crushing	1,019.94	3.01	555.71
Area 120 - Heap Leach Pad & Ponds	220.50	2.01	124.03
Area 128 - CIC Circuit	26.50	0.24	14.91
Area 134 - Reagents	54.01	0.49	30.38
Area 360 - Power	10.00	0.05	5.63
Area 362 - Water Distribution	96.33	0.88	54.19
Area 365 - Laboratory	195.00	1.78	109.69
Total	1,622.28	8.46	894.53

Power requirements for the underground mine at steady state are estimated at 3.6 MW as described in Section 16.2.6.4.

18.2.2 Site Electrical Power Distribution

On-site electricity will be routed to equipment at 4,160V via overhead power lines. Transformers will reduce the voltage from 4,160 to 480V to feed the MCC(s) and distribution panels. Ancillary loads, i.e., lighting, instruments, etc., will be fed through small, dry-type transformers, which will step down from 480V to a range of 220 to 127V.

18.2.3 Backup Power

A 750 kW, 480V diesel-powered backup generator will be installed in the process plant area for emergency power for those parts of the processing system that need to run continuously, which include the process solution pumps to maintain solution circulation, certain items of small equipment within the process plant, thickeners and plant lighting. A diesel fuel tank will provide a minimum of 24 hours of fuel necessary to fulfill the attached equipment power requirements.

18.3 WATER

18.3.1 Water Supply and Requirements

As discussed in Section 17.5, the average water demand estimate is 498,000 m³/year, which includes water for the heap leach facility, crushing, the heap leach recovery plant, the milling and flotation circuit, concentrate handling, tailings facility, dust suppression, road dust control, underground mine requirements, and miscellaneous uses. Water for the Project is assumed to be obtained from dewatering of historical underground workings and voids and wells.

18.3.2 Potable Water

Potable water demands have been estimated at 2.33 m³/hr and will be stored in a 20 m³ potable water tank. Potable water will be required at the administration buildings, laboratory, warehouse, truck shop, and process building. Due to the proximity of the Project to the town of Bear Valley, California, potable water will be sourced from the town water system.

18.3.3 Fire Water and Protection

The source of fire-fighting water for the Fremont Mine will be the 825 m³ (218,000 gallon) raw/fire water tank. The water transmission systems supplying the mine will be designed to meet the pressure and volume requirements to meet fire codes based on the equipment and building types constructed at the mine. Based on the current building sizing and construction, the required fire-fighting water requirement is estimated at 340 m³/hr (1,500 gpm) for two hours with a minimum pressure of 138 kPa (20 psi).

18.3.4 Domestic Wastewater Disposal

Domestic wastewater will be disposed in three septic systems: one located at the process plant building, a second at the Administration Buildings, and the third at the laboratory/warehouse. Based on the estimated domestic wastewater flow rate, each septic system will be designed with a capacity of 5.6 m³ (1,500 gallons). Portable toilets will be used where septic systems are not available.

19.0 MARKET STUDIES AND CONTRACTS

19.1 METAL PRICES AND FOREIGN EXCHANGE

The Author used the approximate 36-month (3-year) average monthly trailing gold price as of October 31, 2022 of US\$1,750/oz for this PEA. Foreign exchange rates were not considered since all costing and revenue was calculated in US dollars.

19.2 CONTRACTS

There are currently no material contracts in place pertaining to the Fremont Gold Project. The Project is open to the spot gold price market and there are no streaming or forward sales contracts in place.

20.0 ENVIRONMENTAL STUDIES, PERMITS, AND SOCIAL OR COMMUNITY IMPACTS

20.1 PROJECT PERMITTING REQUIREMENTS AND STATUS

The Fremont Project is transitioning from an exploration project to a development project on a property with a history of underground mining, mineral processing, and mineral exploration. The Property has been the subject of past underground gold mining activities dating to the 1800s with the last mining and mineral processing activity ceasing circa 1944. The Fremont site can be described as a Brownfield site. However, considering gold mining and mineral processing in the area has occurred over 90 years, the residual impact is small, and the remaining environmental liabilities are limited. Some basic infrastructure is established: roads (Highway 49 crosses the Property), an electric substation that is connected to the regional grid station is on-site, and a private water well and access to two others. Lake McClure, on the Merced River, is located 1.9 miles (3 km) north.

Excepting for permitting (County Administrative Use Permits and Grading Permits) required for mineral exploration initiated in 2013 and completed in 2022 to advance the mineral resource estimate for the Fremont Project, the permitting process for the Fremont Project has not yet begun, and there are no active or open permit applications at this time.

Permitting for the Fremont Project, which is located on private land in Mariposa County California, will progress following well established procedures and requirements defined by local, state, and federal ordinances, laws, and regulations. There are three distinct phases to permitting mining projects on private lands in Mariposa County, California. The process begins with filing applications and supporting documents to obtain the Primary Land Use Entitlements. The second phase involves filing applications and supporting documents to obtain a series of Environmental Resource Permits mostly from state environmental resource agencies and also some local and federal resource agencies. The final phase of the permitting process involves filing applications and associated documents to obtain Site Development and Operating Permits and Approvals from local, state, and federal agencies having jurisdiction over project development and operations.

20.1.1 Primary Land Use Entitlements

The Mariposa County Planning Department (the County) is the Lead Agency for processing and issuing the Primary Land Use Entitlements for the Fremont Project, which are summarized in Table 20.1. The process begins with submittal of an application for a mining land use permit and supporting documents to the County. The use permit is a discretionary permit, and the first for the Project. This will trigger an environmental review required by the California Environmental Quality Act (CEQA). The County will serve as the Lead Agency for the CEQA environmental review process. Commonly, the application package for a mine use permit will include an application with a project description and permit-level designs, a Mine Reclamation Plan, baseline environmental studies and impact evaluations.

TABLE 20.1 PRIMARY LAND USE ENTITLEMENTS AND PROJECT APPROVALS			
Permit/ Authorization	Agency/ Department	Regulatory Requirements	Previously Prepared Documents
County Land Use Permit	Mariposa County Planning Department	Required by Mariposa County Mining Ordinance (Title 17 of the Mariposa County Code) and the County Land Use Zoning Ordinance where proposed land use is conditional	Application for the Pine Tree-Josephine Project
Environmental Impact Report and Evaluation	Mariposa County Planning Department	Required for compliance with the California Environmental Quality Act (CEQA)	September 1987 Draft Environmental Impact Report for the Pine Tree-Josephine Project
Mining/Mine Reclamation Plan including Financial Assurance for Reclamation	Mariposa County Planning Department	Compliance with California's Surface Mining and Reclamation Act (SMARA) and County mine reclamation ordinance	None
Section 106, National Historic Preservation Act (16 USC 470; 36 CFR 62; 36 CFR 65)	California State Office of Historic Preservation/ Mariposa County Planning Department	Avoidance of historic, architectural, archaeological, or cultural characteristics of properties that meet National Register Criteria.	Prior cultural resources reports in 1987 Draft EIR files.

Source: Benchmark Resources (May 2022)

Using information in the application and the supporting documents, the County will determine the appropriate scope of the environmental impact analysis. Following a staff review and analysis under CEQA, the Lead Agency will determine the appropriate scope for the Environmental Impact analysis and commission the preparation of a Draft Environmental Impact Report (DEIR). For new mining projects like the Fremont Project, the scope of the environmental review is comprehensive and includes the characterization of baseline conditions of the Project environmental setting, and evaluation of the associated Project impacts, both adverse and beneficial, including cumulative impacts. Table 20.2 summarizes the probable environmental impact evaluations that will be required for approximately twenty identified environmental issues specific to the Fremont Project.

TABLE 20.2			
IDENTIFIED ENVIRONMENTAL EVALUATIONS POTENTIALLY REQUIRED FOR FREMONT PROJECT ENVIRONMENTAL AND PERMITTING REVIEW PROCESS			
Aesthetics	Recreation	Land Use	Energy
Biological	Utilities	Population	Hazards/Hazardous Materials
Geology	Agriculture/Forestry	Transportation	Mineral Resources
Hydrology	Cultural Resources	Wildfire	Public Services
Noise	Greenhouse Gases	Air Quality	Tribal Cultural Resources

Source: Benchmark Resources (May 2022)

The environmental review process is a local, public process involving characterization of the environmental and evaluation of any constraints imposed by that setting and Project impacts upon that setting. During the process, Project stakeholders will have opportunities to provide feedback and comments on the Project. Stakeholders will include the public, the Project proponent, Non-Governmental Organizations (NGOs), responsible governmental agencies (e.g., environmental resource agencies) having downstream permitting and approval authority and others. Four important milestones in this process are 1) the circulation and public review of the DEIR, 2) preparation of the Final EIR, including comments and responses to comments on the DEIR and 3) preparation of a Lead Agency Staff Report for decision Makers, and 4) County Planning Commission Hearings followed by County Board of Supervisors Hearings. The Board of Supervisors is a locally elected board comprised of five supervisors, one from each District in the County.

The Mine Reclamation Plan follows a parallel but separate path. This begins with a review by the Lead Agency staff followed by submittal to the California Division of Mine Reclamation for a review to assure compliance with California’s Surface Mining and Reclamation Act (SMARA). The Lead Agency Staff Report for Decision Makers includes staff evaluations and findings with respect to the Mine Reclamation Plan, the Final EIR, mitigation measures proposed to mitigate Environmental Impacts and the proposed Mining Land Use Permit, including recommended conditions of approval.

The County Board of Supervisors is the permitting agency for the Primary Land Use Entitlements and will hold one or more public hearings on the Project after the County Planning Commission completes its hearing process. Project and Mine Reclamation Plan approval and Certification of the EIR requires a simple majority vote by the Board of Supervisors. Approval of the Mining Land Use Permit (Conditional Use Permit), Adoption of the Mine Reclamation Plan and Certification of the EIR, constitutes approval of the Primary Land Use Entitlements for the Project.

20.1.2 Environmental Resource Permits

Following approval of the Primary Land Use Entitlements, issuance of the Primary Environmental Resource Permits and Project Approvals can commence. There are a handful of local, state, and federal agencies having Environmental Resource permitting authority for mining and similar

projects in California. Table 20.3 summarizes the permits, associated agencies and regulatory requirements. There is often coordination and communication between the US Army Corps of Engineers (USACE) that issues the Individual/Nationwide Section 404 Discharge Permit and the departments in the California Regional Water Quality Control Board Central Valley Region (RWQCB) that issue the Section 401 Water Quality Certification and the Lake/Streambed Alteration Agreement.

TABLE 20.3 PRIMARY ENVIRONMENTAL RESOURCE PERMITS AND PROJECT APPROVALS			
Permit/ Authorization	Agency/ Department	Regulatory Requirements	Previously Prepared Documents
California Endangered Species Act Section 2081 Permit	California Department of Fish and Wildlife (CDFW)	Activity where incidental take of state-listed threatened or endangered species is anticipated	Prior coordination with CDFW (DFG at the time) included in 1987 Draft EIR records
Waste Discharge Requirements	California Regional Water Quality Control Board, Central Valley Region (RWQCB)	Required prior to discharge of mine wastes to the land California Code of Regulations (CCR) Title 27 (Water Code 13000 et seq)	Application prepared for the 1987 Pine Tree Josephine Mine Project
Individual/Nationwide Section 404 Discharge Permit	US Army Corps of Engineers (USACE)	Compliance with the Clean Water Act (CWA) 33 USC 1341	None
Section 401 (Water Quality) Certification	RWQCB	CWA, 33 USC 1251: <i>If the Project Requires U.S. Army Corps of Engineers 404 permit)</i>	None
Lake/Streambed Alteration Agreement	RWQCB	Fish and Game Code 1603	None
Construction Stormwater Permit; Notice of Intent	RWQCB	40 CFR Part 122	None
Industrial Stormwater Permit; Notice of Intent	RWQCB	40 CFR Part 122	None
National Pollutant Discharge Elimination System (NPDES) Permit	RWQCB	33 USC 1251 et Seq.	None
Water Code 10730; Sustainable Groundwater Management Act	County or local Joint Powers Authority	Management of groundwater basins to prevent overdraft.	None

TABLE 20.3 PRIMARY ENVIRONMENTAL RESOURCE PERMITS AND PROJECT APPROVALS			
Permit/ Authorization	Agency/ Department	Regulatory Requirements	Previously Prepared Documents
Class V Injection Well Permit	US Environmental Protection Agency (USEPA) Region 9	Required for underground mines where mine backfill is proposed	None
Authority to Construct	Mariposa County Air Pollution Control District (APCD)	Compliance with local APCD rules prior to construction of stationary air emission sources (Local Air District rules, per Health and Safety Code 42300 et seq.)	None
Permit to Operate (Local Air District rules)	APCD	Compliance with local APCD rules prior to operation of stationary air emission sources	None

Source: Benchmark Resources (May 2022)

20.1.3 Site Development and Operating Permits and Approvals

Site development and operating permits and approvals are those site-specific approvals required either prior to construction or operation and are typically issued by local, state, or federal agencies through an administrative process typical in the mining industry (Table 20.4).

TABLE 20.4 LOCAL, STATE AND FEDERAL PERMITS AND APPROVALS		
Local	State	Federal
Sewage Disposal Permit	Underground Mine Classification	Legal Identity Report
Hazardous Waste Generator	Underground Diesel Engine Permit	Training Plan
Hazardous Materials Business Plan (HMBP)/Emergency Response Plan	Blaster's License(s)	Mine Rescue Capability
Spill Control Countermeasure Plan (SPCC)	Air Pressure Vessel Operation	Ventilation Plan
Consolidated Emergency Contingency Plan	Cal EPA ID Number	Escape Firefighting and Evacuation Plan
Well Permits	Encroachment Permit(s)	Mine Operation Notification
Building Permits	Hazardous Materials Transportation License	Explosives Permits
Grading Permits	Permit to Appropriate Water	Legal Identity Report

TABLE 20.4		
LOCAL, STATE AND FEDERAL PERMITS AND APPROVALS		
Local	State	Federal
Fire Management Plan		Training Plan

Source: Benchmark Resources (May 2022)

20.2 SUMMARY OF ENVIRONMENTAL STUDIES

The Fremont Property has been the subject of historical, recent, and ongoing environmental studies. The most extensive of these are baseline and other studies conducted in the 1980s for the environmental impact analysis and permitting of the then-proposed Pine Tree Project located on the Property. The Pine Tree Project was never developed. The environmental impact analysis for the Pine Tree Project, which had a much larger footprint than the current Fremont Project, identified some minor environmental constraints and impacts, however, none of these issues are known to have a material impact on the ability to extract the Mineral Resources identified in this PEA. Renewed interest in exploring the Mineral Resource potential of the Property began in 2013 and has continued to date. Mariposa County issued Administrative Use Permits for exploration projects beginning in 2013 and completed in 2022. When issuing these permits, the County found that there were not any significant environmental constraints or impacts associated with the exploration work.

20.2.1 Historical Environmental Studies

In the 1980s Goldenbell Mining Corporation (Goldenbell) proposed to develop, operate, and reclaim a mine, mineral processing and gold recovery project on the Fremont Property referred to as the Pine Tree Project. In September of 1987 Faverty & Associates (Faverty) completed a Draft Environmental Impact Report (DEIR) for Goldenbell's Pine Tree Project. Faverty prepared the DEIR for the Mariposa County Planning Department to satisfy, in part, the requirements for environmental review of the proposed project required by the California Environmental Quality Act (CEQA). Located on private land in Mariposa County California, the proposed Pine Tree Project was subject to an environmental review under California's laws and regulations rather than the federal National Environmental Protection Act (NEPA).

The Mariposa County Planning Department (The County) was and still is the Lead Agency for environmental review of projects, including mining projects, on private lands in Mariposa County. The County developed the Scope of Environmental Concerns for the 1987 DEIR to satisfy the requirements of CEQA as contained in the California Administrative Code (CAC) Sections 15122-15126. Faverty used these concerns to scope the environmental studies and environmental impact analysis in the Pine Tree Project DEIR. The results of the 1987 environmental impact analysis are that most of the impacts from the proposed Project were less than significant or less than significant with mitigation. The results of the 1987 DEIR also identified some significant and unavoidable impacts. The original Pine Tree Project had a much larger footprint, sulphide roaster, acid plant, higher daily throughput, wet tailings management facility, higher water demand, longer highway by-pass, open pit not filled at mine closure and many other aspects not currently proposed in the Fremont Project.

The Fremont Project is expected to represent much lower environmental impacts or risks than the previously proposed Pine Tree Project. A gold-containing sulphide concentrate is proposed to be produced by a conventional grinding-gravity-flotation process and the concentrate will be shipped out of state for processing. The flotation process tailings will mostly be used as mine backfill – residual tailings will be dewatered and “dry stacked” in a confined location on the mine site. Low grade mineralized material will be heap leached on an impermeable pad located on historical tailings. Water conservation will be an important aspect of the proposed Fremont Project which will include the maximum use of mine water and the recycling of concentrate and tailings moisture. Waste rock will be returned to mined-out pits at end of mine life.

Goldenbell did not pursue the permitting process through to completion and ended the process before approval of a Final Environmental Impact Report and issuance of a mining use permit.

20.2.2 Recent and Current Environmental Studies

From 2013 through to present, Stratabound and its predecessors have conducted a series of mineral exploration projects on the Fremont Property under Administrative Use Permits (AUPs) issued by the County. For each AUP the County completed an environmental review of exploration project pursuant to CEQA. In issuing each AUP, including conditions of approval, the County made the following findings:

- The proposed use is consistent with the policies and development standards of the general plan, the zoning ordinance, other county codes, any applicable area plan, and any other applicable code and regulations.
- There is no substantial evidence that the exploration Projects as approved will have significant adverse effect on the environment, and will not be detrimental to the public health, safety, and welfare.
- The Planning Director shall impose any conditions and/or requirements necessary to guarantee compliance with the findings in this Section.
- In accordance with the general rule described in Section 15061 (b)(3) of the CEQA Guidelines, it can be said with certainty that the AUP will not cause a significant effect on the environment.

When Stratabound assumed control of the Fremont Property in 2021, the AUP issued in 2017 was still open. Stratabound completed exploration work under the 2017 AUP and the required reclamation of disturbed areas in the spring of 2022. Subsequently, the County inspected the reclamation work and closed the AUP.

In 2022, Stratabound resumed environmental baseline studies on a selective basis in anticipation of completing the PEA for the Fremont Project and providing a portion of information needed to advance the Project through subsequent stages of exploration, permitting, mine development, operation and closure. Specifically, these included completing a Spring Biological Survey of the Property and resuming surface water and groundwater quality monitoring using monitoring

stations established during baseline studies for the previously proposed Pine Tree Project from the 1980s. The biological, surface water and groundwater baseline studies are ongoing.

20.3 REQUIREMENTS AND PLANS FOR MINE WASTE ROCK AND TAILINGS MANAGEMENT AND DISPOSAL

Preliminary plans in this PEA for management and disposal of mine waste rock and tailings resulting from the Fremont Project include the following:

- Overburden and waste rock not used in construction will be stored in the Waste Rock Storage Facility, located in Rocky Gulch. The Waste Rock Storage Facility has a design capacity of 21.0 million tonnes (Mt) within a 495 thousand square metre (122 acre) footprint. Through progressive and final reclamation of the Pine Tree-Josephine and Queen Specimen open pit mines an estimated 17.5 Mt will be returned to the Pine Tree-Josephine and Queen Specimen pits prior to final contouring, reclamation, and closure of the pits. The remaining 3.5 Mt will be closed in place.
- Tailings will be stored and disposed on the surface using the dry-stack method of placement and in the underground mine workings as paste backfill. Located in the upper reaches of Hell Hollow, the Tailings Storage Facility has a capacity of 19 Mt and a 240 thousand square metre (59 acre) footprint.
- Plans call for constructing a heap leach area of 512kt capacity and footprint within the Tailings Management Facility. Following leaching, the heap leach residuals will remain in this area and be closed in place.

Mining wastes generated by the Fremont Project will be regulated by the RWQCB in accordance with regulations contained in Title 27 of the California Code of Regulations (Title 27 CRC) and the applicable portions of the Porter Cologne Water Quality Control Act. In California, Mining waste means all solid, semisolid, and liquid materials from the extraction, beneficiation and processing of ores and minerals. Mining waste includes, but is not limited to, soil, waste rock, overburden, and tailings, slag, and other processed waste materials. California classifies mine waste into three groups (A, B and C) based on each waste's physical and chemical characteristics that could affect the potential to cause pollution or contamination using the results of tests adopted by the RWQCB and the California Department of Toxic Substances Control. The RWQCB requires the generator or discharger of the mining wastes to evaluate the potential of the discharge of each mining waste to produce, over the long term, acid mine drainage, the discharge or leaching of heavy metals, or the release of other hazardous substances that may persist in the waste after disposal.

In addition to waste classification standards, Title 27 CCR contains waste treatment requirements and siting, design, and construction standards for waste management units (mine waste storage and disposal areas) at mine sites. Among other things these standards require protection from flooding, construction and discharge standards, general containment requirements, waste containment requirements for clays and synthetic liners, leachate collection and removal systems, precipitation and drainage controls and water quality monitoring standards for mine waste units.

Title 27 CCR also includes standards for closure, post-closure monitoring and maintenance of mine waste management units

Mine operators are required to obtain permits to discharge mining wastes to the land, known commonly as Waste Discharge Requirements (WDRs) which are one of the Primary Environmental Resource permits identified and discussed in Section 20.1.2, above. To obtain WDRs mine operators file an application with the RWQCB, submitting an accompanying Report of Waste Discharge describing the mine wastes, their characteristics and test results, the proposed classification of the mine wastes, preliminary waste management unit designs and supporting calculations and management plans. Based on the RWQCB staff's review and evaluation, they will propose tentative WDRs including permit findings, provisions, monitoring and reporting requirements and closure and post closure requirements for consideration by the mine operator prior to submission to their Board for consideration at a public hearing, and adoption.

There is insufficient data at this time to determine the classification of the wastes, and hence, the containment, construction, monitoring and closure/post-closure requirements that will be in the permit issued by the RWQCB. Regardless, the mine operator will be required to obtain WDRs and to manage mine wastes that they generate and discharge in accordance with the requirements of the RWQCB and the applicable regulation in Porter Cologne and Title 27 CCR.

Summarizing above, Stratabound's waste management and mitigation measures include:

1. Maximizing the return, reclamation and contouring of approximately 17.5 Mt of waste rock back into the mined out open pits.
2. Maximizing the return of tailings back underground as paste fill, the remaining stored, reclaimed and contoured by the dry-stack method of tailings.
3. Recycling, reusing and treating all water discharge with, other than evaporation, the objective of achieving zero discharge.
4. Following test work, Stratabound proposes to determine the material's environmental classifications with the intent to repurpose any remaining mine wastes as beneficial aggregate by-products as is successfully done at the Soledad Mountain Gold Mine in Kern County, California.
5. The electric-powered Railveyor™ bulk material transport system to be implemented in the underground mine will not only increase productivity but will obviate the need for approximately five conventional diesel-powered haul trucks thereby reducing related greenhouse gas and particulate air emissions, the related need for underground ventilation, discharge and associated extra power consumption.
6. Ongoing studies will examine the use of the Railveyor™ in the open pit configuration, as well as other electric green-equipment alternatives, automation and state-of-the-art clean technology in further reducing traffic, noise, greenhouse gas and dust emissions.

20.4 SOCIAL AND COMMUNITY-RELATED REQUIREMENTS AND PLANS

Thus far, only informal discussions have been held with members of the community and the County, and therefore, there remains to be negotiations and agreements in effect with the county and local communities. Given that there is insufficient groundwater available on site to meet the Project needs and that surface water rights are controlled by Merced Irrigation District or allocated to the County, agreements will be required to secure a water supply for the Fremont Project.

20.5 MINE RECLAMATION AND CLOSURE/POST-CLOSURE REQUIREMENTS

SMARA and Title 27 CCR, respectively, contain mine reclamation and mine closure/post-closure requirements for mines on private lands in California. The County is the Lead Agency for implementing SMARA mine reclamation requirements for disturbances at surface mines and surface disturbances at underground mines. The Fremont Project includes both a surface mining element and an underground mining component. The RWQCB is responsible for regulating mine closure and post-closure requirements for mine waste storage and disposal units and mine sites. SMARA establishes mine reclamation standards, requirements for preparation and approval of Mine Reclamation Plans and standards for preparing and updating cost estimates for implementing the Mine Reclamation plan based on the degree of mine development and requirements for establishing and maintaining financial assurance for implementing the approved reclamation plan. Title 27 CCR establishes closure and post-closure requirements of mine waste management units and mine sites, closure/post-closure plan requirements, standards for estimating and maintaining closure/post-closure cost estimates and establishing and maintaining financial assurances for closure and post-closure acceptable to the RWQCB.

Closure and post-closure cost estimates are updated annually along with an appropriately funded financial assurance mechanism acceptable to the RWQCB. The RWQCB, provides oversight for these annual cost estimate updates and corresponding adjustments to the financial assurance mechanism that may be warranted. In turn, the County, as Lead Agency for SMARA oversees the annual update of the reclamation cost estimate and any necessary adjustments to the financial assurance mechanism. WDRs issued by the RWQCB typically require establishment and funding of the financial assurance mechanism prior to the discharge of any mining wastes. Establishment and funding of the financial assurance mechanism for implementation of the Mine Reclamation Plan is required following approval of the Mine Reclamation Plan.

In addition to closure/post-closure cost estimates and financial assurance, Title 27 CCR and hence, the RWQCB has required cost estimates and financial assurances for the cost to investigate and remediate “reasonably foreseeable releases”. In some cases, the RWQCB has issued WDRs requiring closure cost estimates and financial assurances for closing mineral processing areas including mineralized material stockpile areas.

This PEA includes a preliminary estimate of reclamation costs of \$30M which has been included in the operating and capital costs (Section 21).

21.0 CAPITAL AND OPERATING COSTS

Total capital costs, operating costs, and royalty payments for the Fremont Gold Project are estimated at \$1.72B, equivalent to \$76.90/t processed, over two years of pre-production development, 11 years of production life and two years of reclamation.

Capital and operating costs for the process, site infrastructure related to processing, and general and administration components of the Fremont Project were estimated by KCA. The mine will utilize Owner mining, and the costs for mining and site infrastructure related to mining were provided by the Authors. The estimated costs are considered to have an accuracy +/- 25-30% and are discussed in this section.

21.1 CAPITAL COSTS

The capital cost estimate addresses the engineering, procurement and start-up costs of the Fremont Gold Project, as well as ongoing sustaining capital expenditures over the life of mine (“LOM”).

Initial capital costs consist of purchases of equipment, preparation of the site, construction of a process plant, tailings storage facility, pre-production mining of the Pine Tree-Josephine open pit, and a one km bypass of Highway 49. Site infrastructure includes an administration office, first aid station and mine rescue training facility, water treatment facilities, mobile equipment maintenance shop and a warehouse. Total initial capital expenditures (“CAPEX”) are estimated at \$176.5M before contingency, \$203.0M after contingency.

No provision has been included in the capital cost for future escalation. All capital costs accrue a 15% contingency. Costs are provided using Q4 2022 US dollars. Table 21.1 presents a breakdown of the capital cost estimate for the Project.

Area	Initial Capital Costs (\$M)	Sustaining Capital Costs (\$M)	Total Capital Costs (\$M) ¹	LOM Cost per Tonne (\$/t)
Open Pit Mining Equipment ²	13.4	36.1	49.5	2.22
Open Pit Pre-Production	7.9	-	7.9	0.35
Site Infrastructure for Mining	16.1	9.9	26.0	1.17
Highway 49 Realignment	14.0	-	14.0	0.63
Process Plant Including Paste Backfill Plant	78.4	-	78.4	3.52
Tailings Thickening, Filtration and Stacking	38.5	2.5	41.0	1.84
Owner’s Costs	8.2	-	8.2	0.37
Heap Leach Facility	-	8.0	8.0	0.36
Underground Mine – Railveyor™ system	-	22.8	22.8	1.02
Underground Mine – all else ²	-	166.6	166.6	7.47

TABLE 21.1
PROJECT CAPEX SUMMARY

Area	Initial Capital Costs (\$M)	Sustaining Capital Costs (\$M)	Total Capital Costs (\$M) ¹	LOM Cost per Tonne (\$/t)
Subtotal	176.5	245.9	422.4	18.94
Contingency @ 15%	26.5	36.9	63.4	2.84
Total	203.0	282.8	485.8	21.78

Notes: ¹ Totals may not sum due to rounding.

² Mining equipment is acquired by a lease-to-own strategy.

21.2 INITIAL CAPITAL COSTS

Initial capital costs are all costs incurred in YR -2 and YR -1. As presented in Table 21.1 above, initial capital costs are estimated at \$203.0M. The following sub-sections provide additional detail.

21.2.1 Open Pit Mining Equipment

Major equipment items for open pit mining are assumed to be purchased on a lease-to-own basis with a 10% down payment. Initial CAPEX includes down payments and the first two years of lease payments on the mine fleet required for pre-production mining as described in Section 16, a fuelling station, communications system, pit dewatering system and explosives storage. Capital expenditures during the pre-production period are estimated at \$13.4M.

21.2.2 Open Pit Pre-production

3.0 Mt of material have been planned for open pit pre-production, consisting of 2.7 Mt waste rock and 0.3 Mt of mineralized material, at a unit cost of \$2.56/t mined, for an estimated capitalized cost of \$7.9M.

21.2.3 Site Infrastructure for Mining

Site infrastructure includes initial roads between the Pine Tree-Josephine open pit and the process plant and waste rock storage facility, clearing and grubbing of the pit and waste rock storage areas, drainage ditches and settling ponds, and buildings such as a gatehouse, administration office, warehouse and truck maintenance shop. It also includes an allowance for improvements to the electrical power installation at site and is estimated to total \$16.1M.

21.2.4 Highway 49 Realignment

A one km section of Highway 49 that runs parallel to the west side of the Pine Tree-Josephine open pit has been planned for realignment. The highway will be relocated approximately 100 m to the west, as shown in the green line in Figure 18.1. It is planned to use waste rock from the open

pit as fill, with gabion support, followed by surface paving. An alternative bypass method could be a bridge, which is recommended for review at the next stage of engineering study. The cost of the highway realignment is estimated at \$14.0M.

21.2.5 Process Plant and Tailings

The estimated required capital costs have been based on the process design introduced in this report. The scope of the costs includes all expenditures for process plant, infrastructure, construction indirect cost and owner's cost, mine contractor mobilization and owner cost for the Project. The costs presented have primarily been estimated by KCA with the inputs from P&E and Stratabound. The cost for earthworks, concrete, structural steel and major piping have been estimated by KCA from similar projects in the Western United States.

21.2.5.1 Process and Infrastructure Cost

All equipment is sized based on the design information as described in this report. The budgetary costs have been estimated primarily based on similar projects KCA has completed in the Western United States, with certain escalation factor applied to 2022 US\$.

Each area in the process cost has been separated into the following disciplines, as applicable:

- Major Earthworks and Liners.
- Civil (concrete).
- Structural Steel.
- Platework.
- Mechanical Equipment.
- Piping.
- Electrical.
- Instrumentation.
- Infrastructure and Buildings.
- Spare Parts.

The total direct capital costs by discipline are presented in Table 21.2.

TABLE 21.2	
SUMMARY OF PROCESS CAPITAL COST / PROCESS PLANT PRE- PRODUCTION CAPITAL COSTS BY DISCIPLINE	
Plant Categories	Grand Total (\$M)¹
Major Earthworks	3.99
Civils (Supply & Install)	3.02
Structural Steelwork (Supply & Install)	5.40
Platework (Supply & Install)	2.23
Mechanical Equipment	57.96

TABLE 21.2	
SUMMARY OF PROCESS CAPITAL COST / PROCESS PLANT PRE- PRODUCTION CAPITAL COSTS BY DISCIPLINE	
Plant Categories	Grand Total (\$M)¹
Piping	7.21
Electrical	5.80
Instrumentation	2.71
Infrastructure & Buildings	4.36
Spare Parts	2.72
Contingency Allowance	5.66
Indirect Costs (% Directs)	3.45
Owner's Costs (% Directs)	2.47
EPCM (% Directs)	13.48
Initial Fills	0.32
Plant Total Direct Costs	120.79

Notes: ¹ Totals may not sum due to rounding.

Freight, customs fees and duties, and installation costs are also considered for each discipline. Freight has been estimated at 10% of the equipment cost. Local sales tax is assumed at 8.75% of the equipment cost. Installation costs are based on the installation hours multiplied with a unit installation rate at \$110/hour. Whenever applicable, the installation cost of similar items from recent KCA projects was used.

21.2.5.2 Capital Costs by Discipline

For the major earthworks, liners, and civils, the quantity and unit costs, KCA took reference from a recent project in California in 2020, and adjusted based on the throughput, mine life and inflation.

Structural steel includes steel grating, structural steel, and handrails. The costs for each area took reference of recent KCA projects with similar process and throughput.

The platework includes tanks, chutes, transfer bins and dump hopper. These costs took reference from a recent KCA project with similar processes, adjusted based on the process requirement, and estimated equipment size, multiplied by an escalation factor.

Costs for mechanical equipment are based on the equipment list developed for all major areas of the process. The equipment cost is estimated based on recent KCA projects with similar process and throughput, and adjusted with escalation factor converted to 2022 US\$.

Piping includes slurry piping, air piping, water distribution pipes, all other piping in the mill areas and in other facilities. The costs are estimated on a percentage basis of the mechanical equipment supply.

Electrical includes transformers, cables, substations, site powerlines, motor control centers equipment. The electrical costs are estimated as percentages of the mechanical equipment supply cost for each area.

Instrumentation costs are estimated as percentage of equipment cost, which varies based on different process areas.

Infrastructure and buildings for the Fremont Project include the construction of an administration building, a process maintenance and warehouse building, a laboratory, reagent storage, and the process plant. The costs took reference from KCA’s recent project with a similar process in California.

Spare parts costs are estimated at an average 4.7% of the mechanical equipment costs.

Mobile equipment costs included in the capital cost estimate are summarized in Table 21.3.

TABLE 21.3 PROCESS MOBILE EQUIPMENT	
Quantity	Description
1	Forklift
1	Boom Truck
1	Mechanic Service Truck
1	Backhoe/Loader
7	Pickup Truck
1	Ambulance
1	Front End Loader
1	Dozer, D6
1	Telehandler
1	Rough Terrain Crane, 60 t
1	Forklift
1	Boom Truck

21.2.5.3 Contingency

Contingency for the process plant and infrastructure has been applied to the total direct costs by discipline. Contingency has been applied from 20 to 25% as listed in Table 21.4. The overall contingency for the process and infrastructure is estimated at 21.8% of the direct costs. A global contingency of 15% was applied to the Project. The credit for the global contingency was applied to the total direct process plant and infrastructure cost contingency.

TABLE 21.4		
PROCESS PLANT AND INFRASTRUCTURE CONTINGENCY		
Direct Plant and Infrastructure Costs Contingency	%	Total Costs (\$M)¹
Major Earthworks	25	1.00
Civils (Supply & Install)	25	0.76
Structural Steelwork (Supply & Install)	25	1.35
Platework (Supply & Install)	25	0.56
Mechanical Equipment	20	11.59
Piping	25	1.80
Electrical	25	1.45
Instrumentation	20	0.54
Infrastructure	25	1.09
Spare Parts	25	0.68
Total Direct Plant & Infrastructure Costs Contingency	21.9	20.82
Credit for global contingency applied elsewhere	(15)	(15.16)
Total Direct Plant and Infrastructure Costs Contingency Allowance	6	5.66

Notes: ¹ Totals may not sum due to rounding.

21.2.5.4 Indirect and Owner's Costs

Indirect field costs include temporary construction facilities, construction services, quality control, survey support, warehouse and fenced yards, support equipment, etc. these costs have been estimated based on 16 months of field construction, and reasonable allowance based on KCA's recent experience. The total indirect cost is estimated at \$3.4M.

The owner's cost will cover labour, offices, home office support, vehicle and travel, consultants during construction. The total owner's cost is estimated at \$2.5M.

21.2.5.5 EPCM, Initial Fills, and Working Capital

The estimated cost for engineering, procurement and construction management ("EPCM") for the development, construction and commissioning are based on a percentage of the total direct capital cost. The EPCM costs cover services and expenses for the following areas:

- Project Management.
- Detailed Engineering.
- Engineering Support.
- Procurement.
- Construction Management.
- Commissioning.
- Vendors' Reps.

The total EPCM cost is estimated at 12.6% of the total direct capital cost, approximately \$13.48M.

Initial fills consist of consumable items stored onsite at the outset of operations, which includes grinding media, flotation reagents and filter cloths. The total cost for initial fills is estimated at \$0.32M.

Working capital is used to cover operating costs from start-up until a positive cash flow is achieved, once a positive cash flow is attained, Project expenses will be paid from the earnings. Working capital for this Project is estimated to be \$4.21M based on 60 days of operation process operating costs.

21.2.6 Owner's Costs

Costs have been estimated for an Owner's team of managers, technicians and support staff to run the mine during the two-year pre-production period. It includes safety, security, and nurses. Allowances for office expenses, environmental expenses, insurance, community services, transportation and temporary accommodation are included. The total cost is estimated at \$8.2M.

21.2.7 Contingency

A contingency of 15% has been applied to all capital costs incurred in the pre-production period. This contingency totals \$26.5M.

21.3 SUSTAINING CAPITAL COSTS

Sustaining capital costs are estimated to total \$283M over the LOM (Table 21.1). The majority of the costs are for underground mine development, followed closely by costs of open pit mining equipment, site infrastructure and the heap leach facility.

21.3.1 Open Pit Mining Equipment

Ongoing lease payments for open pit mining equipment, with replacement equipment as required, is estimated at \$36.1M over the pit production years.

21.3.2 Site Infrastructure for Mining

Sustaining CAPEX for site infrastructure over the production years includes new haul road construction for mining the Queen Specimen open pit, clearing and grubbing of the Queen Specimen pit area, and a dry/change-house for underground operations at an estimated cost of \$9.9M.

21.3.3 Tailings Storage Facility

An expansion to the tailings storage facility is planned in YR 2 of production as a final increase in the capacity of the facility to provide adequate storage space for the remaining tailings produced over the LOM.

21.3.4 Heap Leach Facility

The capital cost estimates presented in this section of the Report have been estimated by KCA, with inputs from P&E and Stratabound, and are based on process design and similar projects in the Western United States. The scope of these costs includes all expenditures for process plant, infrastructure, construction indirect cost and owner's cost, and owner cost for the Project. The heap leach operation will be operated for one year and constructed concurrently with the process plant, sharing some infrastructure with the process plant such as the lined tailings facility and the crusher.

All equipment is sized based on the design information as described in this Report. The budgetary costs have been estimated primarily based on similar projects KCA has completed in the Western United States, with certain escalation factor applied to 2022 US\$.

Each area in the process plant cost has been separated into the following disciplines, as applicable:

- Major Earthworks and Liners.
- Civil (concrete).
- Structural Steel.
- Platework.
- Mechanical Equipment.
- Piping.
- Electrical.
- Instrumentation.
- Infrastructure and Buildings.
- Spare Parts.

The total direct capital costs by discipline are presented in Table 21.5.

Heap Leach Pre-Production Capital Costs by Discipline	Total Costs (\$M)¹
Major Earthworks & Liner	0.27
Civils (Supply & Install)	0.12
Mechanical Equipment	5.80
Piping	0.52
Electrical	0.42
Instrumentation	0.16

TABLE 21.5	
SUMMARY OF PROCESS PLANT CAPITAL COST BY DISCIPLINE	
Heap Leach Pre-Production Capital Costs by Discipline	Total Costs (\$M)¹
Infrastructure	0.12
Spare Parts	0.23
Contingency Allowance	0.31
Indirect Costs (% Directs)	0.11
EPCM (% Directs)	0.95
Plant Total Direct Costs	9.01

Notes: ¹ Totals may not sum due to rounding.

Earthworks and liner costs are included in the process plant capital costs. The heap leach pad will be placed within the same footprint as the process plant dry-stacked tailings.

Freight, taxes, and installation costs are also considered for each discipline. Freight has been estimated at 10% of the equipment cost. Taxes are assumed at 8.75% of the equipment cost. Installation costs are based on the installation hour multiplied with unit installation rate at \$110/hour. Whenever applicable, the installation cost of similar items from recent KCA projects was used.

21.3.4.1 Heap Leach Capital Costs by Discipline

For the major earthwork, liners and civil costs, the quantity and unit costs were taken by KCA from a recent project in California in 2020. The quantity was adjusted based on the throughput and estimated tonnes of material to be heap leached.

Structural steel costs are included in the mechanical equipment costs.

The platework costs are included in the mechanical equipment costs.

Costs for mechanical equipment are based on the equipment list developed for all major areas of the process. The equipment cost is estimated based on recent KCA projects with similar process and throughput, and adjusted with escalation factor converted to 2022 US dollars.

Piping includes lead pad irrigation, gravity solution collection pipes, water distribution pipes, and in other facilities. The costs are estimated on a percentage basis of the mechanical equipment supply.

Electrical includes transformers, cables, motor control centers equipment. The electrical costs are estimated as percentages of the mechanical equipment supply cost for each area.

Instrumentation costs are estimated as percentage of equipment cost, which varies based on different process areas.

Infrastructure and buildings are shared with the process plant facilities and included in the process plant capital costs.

Spare parts costs are estimated at 4.0% of the mechanical equipment costs.

Mobile equipment included in the process plant capital cost estimate is for two pickup trucks.

21.3.4.2 Heap Leach Contingency

Contingency for the heap leach process and infrastructure costs has been applied to the total direct costs by discipline. Contingency has been applied from 20 to 30% as listed in Table 21.6. The overall contingency for the process and infrastructure is estimated at 19.7% of the direct costs. A global contingency of 15% was applied to the Project. The credit for the global contingency was applied to the total direct process plant and infrastructure cost contingency.

TABLE 21.6 HEAP LEACH PROCESS AND INFRASTRUCTURE CONTINGENCY		
Direct Heap Leach Plant and Infrastructure	%	Total Costs (\$M)¹
Major Earthworks	30	0.08
Civils (Supply & Install)	30	0.04
Mechanical Equipment	20	1.10
Piping	20	0.10
Electrical	20	0.08
Instrumentation	20	0.03
Infrastructure	20	0.01
Spare Parts	25	0.06
Total Direct Plant & Infrastructure Costs Contingency	19.7	1.50
Credit for global contingency applied elsewhere	(15)	(1.19)
Total Direct Heap Leach Plant and Infrastructure Costs Contingency Allowance	4.1	0.31

Notes: ¹ Totals may not sum due to rounding.

21.3.4.3 Heap Leach Indirect and Owner's Costs

Heap Leach indirect field costs include temporary construction facilities, construction services, quality control, survey support, warehouse and fenced yards, support equipment, etc. These costs have been estimated based on five months of field construction, and reasonable allowance based on KCA's recent experience. The total indirect cost is estimated at \$0.11M.

The owner's cost is included in the process plant facilities owner's costs.

21.3.4.4 Heap Leach EPCM, Initial Fills, and Working Capital

The estimated cost for the heap leach EPCM for the development, construction and commissioning are based on a percentage of the total direct capital cost. The EPCM costs cover services and expenses for the following areas:

- Project Management.
- Detailed Engineering.
- Engineering Support.
- Procurement.
- Construction Management.
- Commissioning.
- Vendors' Reps.

The total EPCM cost is estimated 12% of the total direct capital cost, approximately \$0.93M.

Working capital is used to cover operating costs from start-up until a positive cash flow is achieved. Once a positive cash flow is attained, project expenses will be paid from the earnings. Working capital for this Project is estimated to be \$0.32M based on 30 days of operation process costs.

After the gold has been recovered from the heap leach facility it is estimated that the processing equipment will have a salvage value of approximately \$1.0M. The equipment will be skid-mounted and easily salvaged.

21.3.5 Underground Mine Development

During the production period, capital development supporting an underground mine below the open pit at the Pine Tree-Josephine Deposit will be undertaken. This includes the development of ramps, level accesses, re-muck bays, and both lateral and vertical infrastructure development. The total cost of capital development during production is estimated at \$66.3M, pre-contingency. Table 21.7 provides details on these costs.

TABLE 21.7		
SUSTAINING UNDERGROUND CAPITAL DEVELOPMENT CAPEX		
Area	Direct Unit Cost (\$/m)¹	Sustaining Cost (\$M)
Ramps	3,201	17.4
Railveyor™ Ramps and Loading Levels	3,046	5.2
Re-muck bays	2,921	1.5
Footwall Drifts and Infrastructure	2,910	32.6
Longhole Drop Raises	1,609	0.3
Alimak Raises	3,097	9.4
Total (pre-contingency)²		66.3

Notes: ¹ Cost for labour, supplies, and equipment directly associated with development. Indirect costs and G&A are applied elsewhere.

² Totals may not sum due to rounding.

21.3.6 Underground Mobile Fleet and Railveyor™ System

The underground mine mobile fleet is comprised of regular trackless units (trucks, LHDs, drills, etc.) acquired through a lease-to-own strategy. Costs associated with capital payments on leases, mobilization, and major overhauls and rebuilds are capitalized.

In addition to the aforementioned mobile fleet, a Railveyor™ system has been planned for the underground mine. Trains load from chutes on a main haulage level, fed by broken material rock passes. The Railveyor™ will transport broken material from an underground loading level, along a dedicated ramp, and out the portal. From the portal, the system will transport material up a surface hillside to a stockpile area at the process plant. The system will have a maximum haul distance of 4.3 km (1.7 km underground, 2.6 km on surface), from underground to the process plant.

Total costs of the underground mobile fleet and Railveyor™ system are estimated at \$82.8M, pre-contingency. Table 21.8 provides details on these costs.

TABLE 21.8	
UNDERGROUND MOBILE FLEET AND RAILVEYOR™ CAPEX	
Area	Sustaining Cost (\$M)
Mobile Fleet Mobilization and Capital Payments	36.0
Mobile Fleet Major Overhauls and Rebuilds	24.0
Railveyor™	22.8
Total ¹	82.8

Note: ¹ Totals may not sum due to rounding.

21.3.7 Underground Mine Infrastructure

In addition to development capital, fixed infrastructure items will be acquired and installed in the underground mine. These items include, but are not limited to: ventilation, dewatering and electrical infrastructure; backfill systems; construction and fitment; and initial purchase of software and communications infrastructure. Total costs of underground infrastructure items are estimated at \$25.8M, pre-contingency. Table 21.9 provides details on these costs.

Area	Sustaining Cost (\$M)
Ventilation, Dewatering, and Electrical	17.1
Backfill Systems	3.1
Construction and Fitment	5.1
Software, Communications and IT	0.5
Total ¹	25.8

Note: ¹ Totals may not sum due to rounding.

21.3.8 Underground Mine Project Costs

During initial development of the underground mine, costs normally associated with operations (delineation drilling, power costs, indirect salaries and G&A, interest on fleet leases, dayworks and sundries) will be incurred prior to the start of underground production. These costs have been capitalized, and are estimated at \$14.5M, pre-contingency.

21.3.9 Contingency

A contingency of 15% has been applied to all sustaining capital costs incurred during the production period and totals \$36.9M.

21.4 OPERATING COSTS

Total OPEX for open pit and underground mining and processing at the Project is estimated at \$1,163M from YR 1 to YR 13, at an average cost of \$52.05/t processed.

No provision has been included in the operating cost for future escalation. No contingency is applied to operating costs. Costs are provided using Q4 2022 US dollars. Table 21.10 presents a breakdown of OPEX for the Project.

**TABLE 21.10
PROJECT OPEX SUMMARY**

Area	Total Operating Cost (\$M)	LOM Unit Cost (\$/t)
Open Pit Mining		Cost per Tonne Mined (\$/t)
Open Pit Mining Cost per Tonne Material Moved ¹		2.81
Open Pit Mining Cost per Tonne Mined ²		4.08
Whole Operation		Cost per Tonne Processed (\$/t)
Open Pit Mining	173.3	16.62
Underground Mining	531.8	46.69
Process Plant	255.3	11.70
Heap Leach Processing	3.6	7.07
Concentrate Transport	141.4	6.48
General and Administration	57.0	2.55
Total ³	1,162.5	52.05

Notes:

1. Includes open pit mining, stockpile rehandling and backfilling the open pits with waste rock.
2. For mining the Pine Tree-Josephine Pit and the Queen Specimen Pit.
3. Totals may not sum due to rounding.

21.4.1 Open Pit Mining

A breakdown of the open pit mining costs by activity is shown in Table 21.11. Total OPEX for during the production period is estimated at \$173.3M or \$2.81/t moved. Tonnes moved includes all open pit mining, stockpile re-handling and backfilling of the open pits with waste rock. Backfilling is done progressively over the mine life with final filling of the open pits during the last two years of mine life.

**TABLE 21.11
OPEN PIT MINING OPEX**

Area	Total Operating Cost (\$M)	LOM Cost per Tonne Moved (\$/t)
Drilling	14.2	0.23
Blasting	12.3	0.20
Loading	22.5	0.37
Hauling	70.4	1.14

TABLE 21.11 OPEN PIT MINING OPEX		
Area	Total Operating Cost (\$M)	LOM Cost per Tonne Moved (\$/t)
Services, Roads, Dumps	29.3	0.48
Supervision and Technical	16.4	0.27
Other	8.3	0.13
Total ¹	173.3	2.81

Note: ¹. Totals may not sum due to rounding.

21.4.2 Underground Mining

Underground mining includes all activities associated with operating development, mineralized material production, delineation drilling, backfilling, electrical power, interest on mobile equipment leases, dayworks and sundries, indirect salaries, and underground mining-specific G&A expenditures after the start of YR 2 of the Project. Costs associated with the initial development and construction of the underground mine in YR 1 of the Project have been capitalized. Total OPEX cost for the underground mine is estimated at \$531.8M or \$46.69/t mined. Table 21.12 shows details of these costs.

TABLE 21.12 UNDERGROUND MINING OPEX		
Area	Total Operating Cost (\$M)	LOM Cost per Tonne Mined (\$/t)
Operating Development – Mineralized Material	46.3	4.07
Operating Development – Waste Material	15.2	1.34
Production Operations	239.3	21.01
Backfilling Operations	55.6	4.88
Delineation Drilling	11.3	0.99
Power Costs	30.7	2.70
Indirect Salaries and UG-specific G&A	118.4	10.39
Dayworks and Sundries	11.6	1.02
Interest on Leases	3.4	0.30
Total ¹	531.8	46.69

Note: ¹ Totals may not sum due to rounding.

21.4.3 Process Plant

Process plant operating costs have been estimated based on the information extracted from metallurgical tests, the operating cost inputs provided by Stratabound, and experience from KCA's recent projects with similar process in the Western United States. The average annual process costs and unit costs are presented in Table 21.13.

TABLE 21.13		
AVERAGE PROCESS PLANT OPERATING COST		
6,000 tpd Mill, Flotation	tonne/year	2,190,000
Process Category	Annual Cost (\$M)¹	Material Costs (\$/t)
Labour		
Process	5.57	2.54
Laboratory	1.21	0.55
Subtotal - Labour	6.78	3.10
Area 0113 - Crushing		
Power	0.71	0.32
988 Loader	0.54	0.25
Wear	0.44	0.20
Overhaul & Maintenance	0.33	0.15
Subtotal - Crushing	2.02	0.92
Area 0116 - Grinding		
Power	3.33	1.52
Mill Balls	2.06	0.94
Mill Liners	0.32	0.15
Wear	0.22	0.10
Maint. Parts	1.15	0.53
Lubrication	0.08	0.04
Subtotal - Grinding	7.15	3.27
Area 0117 - Gravity Concentration		
Power	0.23	0.11
Misc. Operating Supplies	0.04	0.02
Maintenance Supplies	0.48	0.22
Subtotal - Gravity Concentration	0.76	0.35
Area 0121 - Flotation		
Power	1.62	0.74
Misc. Operating Supplies	0.04	0.02

TABLE 21.13		
AVERAGE PROCESS PLANT OPERATING COST		
6,000 tpd Mill, Flotation	tonne/year	2,190,000
Process Category	Annual Cost (\$M)¹	Material Costs (\$/t)
Maintenance Supplies	0.48	0.22
Subtotal - Flotation	2.14	0.98
Area 0470 - Tails Thickening, Filtration and Stacking		
Power	1.82	0.83
Filter Cloth	0.77	0.35
Misc. Operating Supplies	0.11	0.05
Maintenance Supplies	0.13	0.06
Subtotal - Tails Thickening, Filtration and Stacking	2.83	1.30
Area 0270 - Tailings Paste Backfill		
Power	0.21	0.10
Cement (3% Binder) Incl in Mining OPEX	0	0.00
Misc. Operating Supplies	0.11	0.05
Maintenance Supplies	0.02	0.01
Subtotal - Tailings Paste Backfill	0.34	0.16
Area 0130 - Concentrate Handling		
Power	0.06	0.03
Filter Cloth	0.77	0.35
Misc. Operating Supplies	0.02	0.01
Maintenance Supplies	0.02	0.01
Subtotal - Concentrate Handling	0.87	0.40
Area 0134 - Reagents		
Power	0.02	0.01
Collector (PAX)	0.82	0.38
Promoter (Aero208)	0.46	0.21
Frother (MIBC)	0.40	0.18
Maintenance Supplies	0.02	0.01
Subtotal - Reagents	1.72	0.79
Area 0160 - Process Emergency Power		
Power	0.01	0.00
Overhaul & Maintenance	0.02	0.01
Subtotal - Process Emergency Power	0.02	0.01

TABLE 21.13		
AVERAGE PROCESS PLANT OPERATING COST		
6,000 tpd Mill, Flotation	tonne/year	2,190,000
Process Category	Annual Cost (\$M)¹	Material Costs (\$/t)
Area 0162 - Water Supply & Distribution		
Power	0.13	0.06
Maintenance Supplies	0.04	0.02
Subtotal - Water Supply & Distribution	0.18	0.08
Area 0365 - Laboratory		
Assays, Solids	0.49	0.23
Assays, Solutions	0.27	0.13
Misc. Supplies	0.02	0.01
Subtotal - Laboratory	0.79	0.36
Area 0366 - Facilities		
Power	0.04	0.02
Misc. Supplies	0.02	0.01
Subtotal - Facilities	0.06	0.03
Area 0367 - Support Services / Mobile Equipment		
Forklift, 2.5 t	0.01	0.01
Telehandler	0.01	0.01
Boom Truck 30 t	0.05	0.02
Backhoe/loader	0.01	0.01
Pickup Trucks (10)	0.36	0.16
Maintenance Truck	0.20	0.09
Crane - Rough Terrain	0.01	0.01
Bobcat	0.10	0.05
Maintenance Supplies	0.04	0.02
Subtotal - Support Services / Mobile Equipment	0.79	0.36
Total Cost	25.63	11.70

Note: Totals may not sum correctly due to rounding.

21.4.3.1 Process Plant Labour Cost

Staffing requirement for process has been estimated by KCA based on a similar size operation with inputs from P&E and Stratabound on the wages and salary information. Staffing will be primarily by the regional workforce with the emphasis of hiring as many workers from the local community as possible. Total process personnel are estimated at 48 persons plus 13 laboratory workers. Personnel requirements and costs are estimated at \$6.8M per year and are summarized in Table 21.14.

Description	Number of Personnel	Annual Cost (\$M) ¹
Process Supervision	4	0.52
Crushing	9	1.03
Process Plant	13	1.38
Tailings Filtration/Stacking	8	0.90
Process Maintenance	14	1.74
Laboratory	13	1.21
Total	61	6.78

Notes: ¹ Totals may not sum due to rounding.

21.4.3.2 Electrical Power

Electrical power usage for the process and process related infrastructure was derived from estimated connected loads assigned to powered equipment from the mechanical equipment list. Equipment electrical power demands under normal operation were assigned and coupled with estimated on-stream times to determine the average energy usage and cost. Electrical power requirements for the Project are presented in Table 21.15. The total attached electrical power for the process plant and infrastructure is estimated at 10.26 MW, with an average draw of 7.65 MW.

Area/Description	Total Connected Load (kW)	Average Demand (kW)
Area 0113 - Crushing	1,180	664
Area 0116 - Grinding	3,553	3,115
Area 0117 - Gravity Concentration	222	216
Area 0121 - Flotation	2,078	1,511
Area 0470 - Tails Thickening, Filtration and Stacking	2,172	1,707
Area 0270 - Tailings Paste Backfill	655	197

**TABLE 21.15
PROCESS PLANT POWER DEMAND**

Area/Description	Total Connected Load (kW)	Average Demand (kW)
Area 0130 - Concentrate Handling	76	56
Area 0134 - Reagents	20	15
Area 0160 - Process Emergency Power	10	6
Area 0162 - Water Supply & Distribution	224	126
Area 0366 - Facilities	70	39
Total	10,260	7,651

Note: Totals may not sum correctly due to rounding.

The total electrical power consumption is estimated 67.0M kWh/yr. The power will be sourced from the substation located at the Project site. Based on published commercial power costs the unit cost of the power is estimated at \$0.12/kWh.

21.4.3.3 Consumables

Consumables include steel wear, mill balls, mill liners, mobile equipment wear and spare parts, piping, filter cloths for filter presses, laboratory consumables, and other miscellaneous operating consumables. The total cost for consumables per year is estimated at \$5.0M.

21.4.3.4 Maintenance

Labour associated with maintenance is included in the process plant labour cost. The maintenance cost mainly includes the maintenance supplies for process. The estimated the maintenance cost per year is estimated at \$2.7M.

21.4.3.5 Reagents

Reagents includes flotation reagents (Collector, Promoter, and Frother) and other miscellaneous reagents in the process. The total reagents cost per year is estimated at \$1.68M.

21.4.4 Heap Leach Processing

The average annual heap leach processing operating costs are presented in Table 21.16.

TABLE 21.16
AVERAGE HEAP LEACH PROCESSING OPERATING COST

Phase 1 Heap Leach Operating Cost/Year	tonne/year = 547,500	
Heap Leach Category	Annual Costs (\$M) ¹	Mineralized Material (\$/t)
Labour		
Heap Labour	1.28	2.44
Laboratory	0.18	0.34
Subtotal	1.45	2.78
Area 113 - Crushing		
Power	0.20	0.38
Loader	0.07	0.14
Wear	0.10	0.20
Overhaul / Maintenance	0.05	0.10
Subtotal	0.43	0.82
Area 120 - Heap Leach Pad & Ponds		
Power	0.13	0.25
Heap Dozer (D6 or equiv.)	0.04	0.09
Piping/Drip tubing	0.02	0.03
Maintenance Supplies	0.01	0.02
Subtotal	0.21	0.39
Area 128 - CIC Circuit		
Power	0.02	0.03
Carbon Consumption (Replacement Cost)	0.04	0.09
Carbon Stripping & Refining Cost	0.05	0.10
Carbon Shipping Cost	0.02	0.03
Maintenance Supplies	0.01	0.02
Subtotal	0.14	0.27
Area 134 - Reagents		
Power	0.02	0.04
Cyanide (Mineralized Material)	0.64	1.23
Cement	0.36	0.70
Antiscalant	0.01	0.03
Maintenance Supplies	0.01	0.01
Subtotal	1.04	1.99
Area 360 - Power		
Power	0.00	0.00

TABLE 21.16		
AVERAGE HEAP LEACH PROCESSING OPERATING COST		
Phase 1 Heap Leach Operating Cost/Year	tonne/year = 547,500	
Heap Leach Category	Annual Costs (\$M)¹	Mineralized Material (\$/t)
Miscellaneous Supplies	0.01	0.01
Subtotal	0.01	0.01
Area 362 - Water Distribution		
Power	0.01	0.01
Maintenance Supplies	0.00	0.00
Subtotal	0.01	0.01
Area 365 - Laboratory		
Power	0.06	0.12
Assays, Solids	0.11	0.21
Assays, Solutions	0.03	0.05
Miscellaneous Supplies	0.01	0.01
Subtotal	0.20	0.39
Area 367 - Mobile Equipment		
Mobile Equipment		
Mechanic Service Truck	0.02	0.04
Backhoe/Loader	0.05	0.09
Pickup Truck	0.16	0.30
Subtotal	0.22	0.43
Total	3.70	7.07

Note: Totals may not sum correctly due to rounding.

21.4.4.1 Heap Leach Process Labour Cost

Staffing requirement for heap leach processing has been estimated by KCA based on a similar size operation with inputs from P&E and Stratabound on the wages and salary information. Staffing will be primarily by the regional workforce with the emphasis of hiring as many workers from the local community as possible. Total heap leach process personnel are estimated at 12 persons plus two laboratory workers. Personnel requirements and costs are estimated at \$1.45M per year and are summarized in Table 21.17.

Description	Number of Personnel	Cost (\$M/yr)
Crushing and Screening	3	0.35
Heap Leach	4	0.40
Recovery Plant	4	0.40
Maintenance	1	0.13
Laboratory	2	0.18
Total	14	1.45

21.4.4.2 Heap Leach Electrical Power

Electrical power usage for heap leach processing and related infrastructure was derived from estimated connected loads assigned to powered equipment from the mechanical equipment list. Equipment electrical power demands under normal operation were assigned and coupled with estimated on-stream times to determine the average energy usage and cost. Electrical power requirements for heap leach processing are presented in Table 21.18. The total connected load for heap leach processing and infrastructure is estimated at 1.62 MW, with an average draw of 0.89 MW.

Area/Description	Total Connected Load (kW)	Average Demand, (kW)
Area 113 - Crushing	1,020	556
Area 120 - Heap Leach Pad & Ponds	221	124
Area 128 - CIC Circuit	27	15
Area 134 - Reagents	54	30
Area 360 - Power	10	6
Area 362 - Water Distribution	96	54
Area 365 - Laboratory	195	110
Total	1,622	895

Note: Totals may not sum correctly due to rounding.

The total power consumption is estimated at 4.6M kWh/yr. The electrical power will be sourced from the substation located at the Project site. Based on published commercial electrical power costs the unit cost is estimated at \$0.12/kWh.

21.4.4.3 Heap Leach Consumables

Consumables include steel wear, mobile equipment wear and spare parts, piping and dripping tubes, laboratory consumable, and other miscellaneous operating consumables. The total cost for consumables per year is estimated at \$0.13M.

21.4.4.4 Heap Leach Maintenance

Labour associated with the maintenance is included in the process labour cost. The maintenance cost mainly includes the maintenance supplies for process. The estimated the maintenance cost per year is estimated at \$0.08M.

21.4.4.5 Heap Leach Reagents

Reagents includes cyanide, lime, anti-scalant, activated carbon and other miscellaneous reagents in the process. The total reagents cost per year is estimated at \$1.06M.

21.4.4.6 Heap Leach General and Administrative Operating Costs

The G&A expense for the heap leach is included in the process plant operating costs.

21.4.5 Concentrate Transport

Transport of gold concentrate from the process plant is estimated to cost \$140/wmt to a Nevada-based roaster destination. Using a mass pull of 20:1 (mineralized tonnes:concentrate tonnes) and a moisture content of 8%, the unit cost is estimated at \$6.48/t processed, for a total of \$141.4M over the LOM.

21.4.6 General and Administration

G&A costs are estimated at \$5M/year for a total of \$57M over the LOM, or \$2.55/t processed. Costs have been estimated for a team of 30 managers, technicians and support staff to run the operation over the LOM, including safety, medical and security. Costs include office expenses, environmental expenses, insurance, community services, IT and maintenance of the site buildings.

21.5 ROYALTIES

The Project is subject to a 3% NSR royalty. Total royalty payments are estimated at \$68.4M over the LOM.

21.6 CLOSURE COSTS

Closure costs are estimated at \$27M for open pit mining and G&A OPEX during the last two years of mine life to backfill the open pits with waste rock. Another \$8M is estimated for closure costs to seal the underground portal, remove buildings and other infrastructure, profile and seed the remaining waste rock stored on surface, and rehabilitate the Project site. A salvage value for

equipment at the end of the mine life is estimated at \$5M. Therefore a net amount of \$30M is required at the end of the mine life for closure costs. It is assumed that the \$30M will be instituted with a letter of credit that will start at \$7.5M during pre-production and increase to \$30M by the end of production YR 3. The financial assurance will incur an interest rate estimated at 3.3% per annum, equivalent to \$10.9M over the LOM.

21.7 CASH COSTS AND ALL-IN SUSTAINING COSTS

Cash costs over the LOM, including royalties, are estimated to average \$924/oz of gold. All-In Sustaining Costs (“AISC”) over the LOM are estimated to average \$1,162/oz of gold and include closure costs.

22.0 ECONOMIC ANALYSIS

Cautionary Statement - The reader is advised that the PEA summarized in this Technical Report is intended to provide only an initial, high-level review of the Project potential and design options. The PEA mine plan and economic model include numerous assumptions and the use of Inferred Mineral Resources. Inferred Mineral Resources are considered to be too speculative to be used in an economic analysis except as allowed by NI 43-101 in PEA studies. There is no guarantee the Project economics described herein will be achieved.

Economic analysis for the Fremont open pit and underground Project has been undertaken for the purposes of evaluating potential financial viability of the Project. NPV and IRR estimates are calculated based on a series of inputs: costs (described in Section 21) and revenues (detailed in this section). Revenues are derived from estimated process recoveries and smelter payables.

Sensitivity analysis has been completed for post-tax NPV and IRR on a $\pm 30\%$ range of values for gold price, gold recovery and OPEX and CAPEX costs. Finally, sensitivity to discount rate has been performed for a $\pm 4\%$ variance on the expected value of 5%. Foreign exchange rate sensitivity has not been performed, since both costs and revenues are accrued in US dollars. All costs in the financial analysis are in US dollars.

Under baseline scenarios (5% discount rate, US\$1,750/oz gold price, OPEX and CAPEX as set out in Section 21), the overall post-tax NPV of the Project is estimated at \$217M (\$328M pre-tax), with an IRR of 21.4%. This results in a payback period of approximately 4.2 years.

22.1 PARAMETERS

The revenue, and therefore profit and NPV, of the Project are influenced by the parameters detailed in the Sections 22.1.1 to 22.1.5. Cost estimates are detailed in Section 21.

22.1.1 Gold Price

The gold price is based on the 3-year average monthly trailing price as of end of October 2022, with minor adjustment, and is projected at US\$1,750/oz.

22.1.2 Discount Rate

A 5% discount rate was selected for the Project. Existing infrastructure includes roads, power lines, and an administration building. A skilled labour pool is available nearby, and there is a history of producing operations.

22.1.3 Costing

Costing has been performed from first principles using input from industry databases (CostMine), factors derived from the Author's experience in similar geological settings, and the current US labour market. The mining methods utilize proven extraction methodologies (conventional open

pit mining, and underground longhole stoping with paste backfill) with predictable costs for consumables, equipment, and labour.

22.1.4 Other Inputs

The economic analysis is valid for the LOM production schedule presented in Section 16. The schedule includes a reasonable ramp-up of the process plant in YR 1 with Q1 at 60%, Q2 at 80%, Q3 at 90%, and Q4 at 100% for an average of 85% for the year.

The flotation process plant production rate is set at 2.19Mtpa, which is an average 6,000 tpd throughput rate for 365 days per year of processing. Open pit production of mineralized material is higher than processing plant throughput, and therefore a stockpiling strategy is used to limit low-grade material sent to the process plant and provide a buffer for potential short-term impacts on production. A stockpile of 1.4Mt grading 0.67 g/t Au is built up during open pit mining, and is blended with underground material to sustain full process plant capacity until the last two years of production.

22.1.5 Royalty and Taxes

The Project is subject to a 3% NSR royalty.

Taxes are estimated at 21% for Federal income tax and 8.8% for California State income tax, for a maximum rate of 29.8% on taxable income.

22.2 SIMPLIFIED FINANCIAL MODEL

Table 22.1 shows a simplified financial model for the Project, using baseline inputs (5% discount rate, US\$1,750/oz gold price, OPEX and CAPEX as set out in Section 21).

**TABLE 22.1
SIMPLIFIED FINANCIAL MODEL**

Item	Units	YR -2	YR -1	YR 1	YR 2	YR 3	YR 4	YR 5	YR 6	YR 7	YR 8	YR 9	YR 10	YR 11	YR 12	YR 13	Total ¹
Oxide Mineralization Mined	Mt		0.07	0.44													0.51
Open Pit Sulphide Mined	Mt		0.26	2.00	3.21	2.50	0.33	0.75	0.75	0.64							10.45
Total Open Pit Material Mined	Mt		3.07	14.44	7.60	7.20	0.45	5.94	4.08	2.80							45.58
Waste Rock Backfilled to Pits	Mt														8.74	8.92	17.65
UG Mineralization Mined	Mt					0.14	1.44	1.44	1.44	1.44	1.44	1.44	1.44	1.17			11.39
Total Mineralization Mined	Mt		0.33	2.44	3.21	2.64	1.77	2.19	2.19	2.08	1.44	1.44	1.44	1.17			22.36
Processed	Mt			2.37 ²	2.19	2.19	2.19	2.19	2.19	2.19	2.19	2.02	1.44	1.17			22.36
Process Grade	g/t Au			2.02	2.03	1.89	2.95	2.63	2.58	2.44	2.24	2.38	2.79	2.88			2.41
Oxide Gold Recovered	koz			11.42													11.42
Sulphide Gold Recovered	koz			104.85	107.78	100.33	156.95	139.72	137.13	129.64	119.10	116.68	97.44	81.79			1,291.42
Payable Gold	koz			116.26	107.78	100.33	156.95	139.72	137.13	129.64	119.10	116.68	97.44	81.79			1,302.84
NSR Revenue	\$M			203.5	188.6	175.6	274.7	244.5	240.0	226.9	208.4	204.2	170.5	143.1			2,280.0
Operating Cost	\$M			(74.2)	(66.3)	(89.5)	(117.4)	(137.4)	(127.8)	(132.9)	(116.2)	(114.0)	(95.2)	(64.7)	(10.9)	(16.2)	(1,162.5)
Working Capital	\$M		(9.3)	(9.3)											18.6		0.0
Royalty	\$M			(6.1)	(5.7)	(5.3)	(8.2)	(7.3)	(7.2)	(6.8)	(6.3)	(6.1)	(5.1)	(4.3)			(68.4)
CAPEX ³	\$M	(40.2)	(162.8)	(18.4)	(85.7)	(55.2)	(31.5)	(21.5)	(26.8)	(17.2)	(18.0)	(4.5)	(3.7)	(0.4)			(485.8)
Reclamation Bond Interest	\$M		(0.2)	(0.5)	(0.7)	(1.0)	(1.0)	(1.0)	(1.0)	(1.0)	(1.0)	(1.0)	(1.0)	(0.7)	(0.5)	(0.2)	(10.9)
Cash Flow (Pre-Tax)	\$M	(40.2)	(172.3)	95.0	30.3	24.6	116.5	77.2	77.2	69.1	67.0	78.7	65.6	73.0	7.2	(16.4)	552.3
Income Taxes	\$M			(13.2)	(13.8)	(6.7)	(32.7)	(15.3)	(16.8)	(12.2)	(16.0)	(15.5)	(11.3)	(14.3)	3.4	4.9	(159.5)
Cash Flow (Post-Tax)	\$M	(40.2)	(172.3)	81.8	16.5	17.9	83.8	62.0	60.4	56.8	51.0	63.2	54.2	58.7	10.6	(11.5)	392.8
Cumul. Cash Flow (Post-Tax)	\$M	(40.2)	(212.5)	(130.8)	(114.3)	(96.3)	(12.5)	49.5	109.9	166.7	217.6	280.8	335.1	393.8	404.3	392.8	
Annual Post-Tax NPV Addition	\$M	(38.3)	(156.3)	70.6	13.6	14.1	62.6	44.0	40.9	36.6	31.3	36.9	30.2	31.1	5.3	(5.5)	217.1
Cumul. Post-Tax NPV at EOY	\$M	(38.3)	(194.6)	(124.0)	(110.4)	(96.3)	(33.8)	10.3	51.1	87.8	119.0	156.0	186.2	217.3	222.7	217.1	

Note: YR = year, EOY = end of year, all \$ values are in US\$.

1. Totals may not sum due to rounding.

2. Includes heap leaching.

3. CAPEX expenditures include 15% contingency. All expenditures in YR -2 and YR -1 have been capitalized, including items that would normally be OPEX.

Table 22.2 shows the NPV, IRR and payback period of the Project under baseline inputs.

TABLE 22.2			
PAYBACK PERIOD, NPV AND IRR FOR BASELINE FINANCIAL MODEL			
Item	Payback Period (years)	NPV (\$M) (5% discount rate)	IRR ¹ (%)
Pre-Tax	3.5	328	28.6
Post-Tax	4.2	217	21.4

Note: 1. IRR value was calculated using Microsoft Excel's IRR function.

22.3 SENSITIVITY

Project sensitivity has been analyzed on both an NPV and IRR basis for the impact of changes to gold price, OPEX costs and CAPEX costs for a variance of $\pm 30\%$ from the baseline costs stated in Section 21. The Project NPV sensitivity to discount rate was also analyzed for 0, 5, 8 and 10% discount rates. IRR is insensitive to discount rate and has not been analyzed as a result.

Variance in OPEX and CAPEX can be the result of changes in the United States labour market, increase in raw materials costs, changes in mining or processing parameters, changes in scale or design, changes in technology, general inflation, and other sources. Gold price variance can be the result of changes in banking policies, market trends, general supply and demand pressures, and other sources. Variance in discount rate can be the result of market trends, changes in perceived risk, banking policies, corporate financing structure, and other sources.

The Project IRR is most sensitive to changes in OPEX costs, then CAPEX, and finally gold price. When comparing the impacts of the same factors the Project NPV remains most sensitive to changes in OPEX, followed by gold price, then CAPEX, and finally discount rate. Figure 22.1 shows the Project NPV sensitivity to OPEX, CAPEX and gold price, while Figure 22.2 shows the Project IRR sensitivity. Table 22.3 shows the Project sensitivity to discount rate.

TABLE 22.3	
PROJECT SENSITIVITY TO DISCOUNT RATE	
Discount Rate (%)	Post-Tax NPV (\$M)
0	393
5	217
8	148
10	112

FIGURE 22.1 PROJECT POST-TAX NPV SENSITIVITY

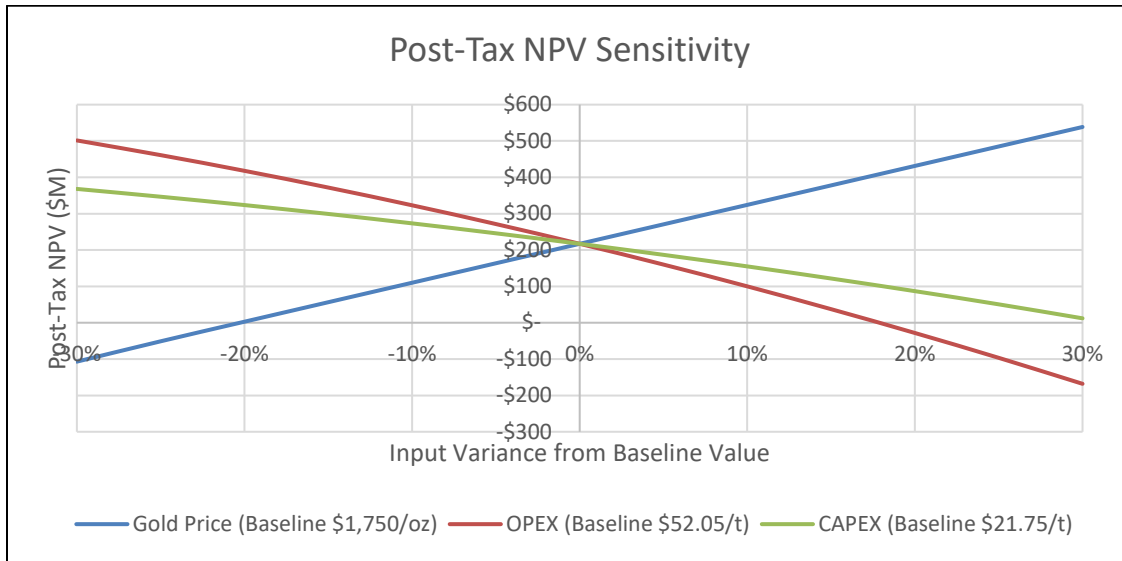
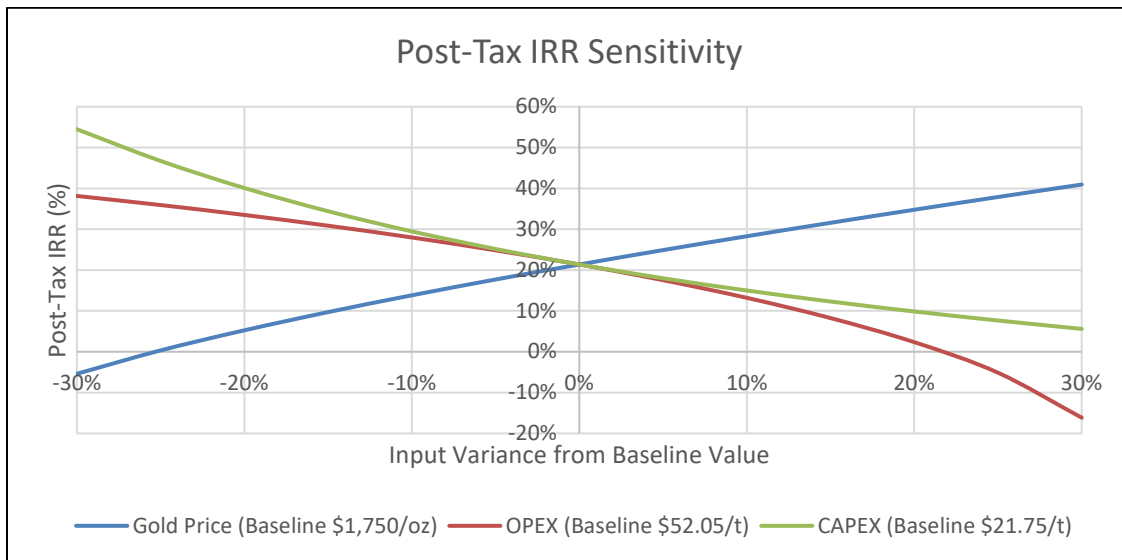

FIGURE 22.2 PROJECT POST-TAX IRR SENSITIVITY



22.4 SUMMARY

The Project is most sensitive to items directly affecting the operating cost. The discount rate has the least overall impact on the Project post-tax NPV and IRR.

It is the opinion of the Author that the Fremont open pit and underground Project has potential to be financially viable. Therefore, it is recommended to advance the Project to the next phase of study.

23.0 ADJACENT PROPERTIES

There are no active gold properties adjacent to the Fremont Property. Historical mines Potosi, Malvera, Tyro, Mary Harrison, Virginia, and Red Bank are located approximately 12 km (8 miles) north of the Pine Tree-Josephine Deposit. Historical mines Yellowstone, Mt. Gaines, Mt. Ophir and Princeton are located approximately 10 km (6 miles) to the south.

The reader is cautioned that the information above has not been verified by the Authors and is not necessarily indicative of the mineralization on the Property that is the subject of this Report.

24.0 OTHER RELEVANT DATA AND INFORMATION

Risks and opportunities have been identified for the Project. The anticipated impact on the Project is listed in brackets after each item, using low-medium-high categories.

24.1 RISKS

24.1.1 Mineral Resource Estimate

Future metal prices could cause a revision of the Mineral Resource Estimate. However, current spot prices are greater than the long-term forecasts used to determine Mineral Resources in this PEA. (low)

24.1.2 Open Pit Mining

The Mineral Resource in the open pit mine plan consists of approximately 77% Indicated Mineral Resources and 23% Inferred Mineral Resources. Infill drilling is required to potentially convert Indicated to Measured and Inferred to Indicated Mineral Resources and increase the confidence in the Mineral Resource Estimate. (medium)

Updated geotechnical analysis is required to confirm the previously evaluated open pit wall slope angles. (low)

Hydrogeology is not well understood and requires study, however, this should have little impact on the open pit with the open underground adits below the open pit bottom level where the water can drain. (low)

The Project is located on relatively steep topography and requires well engineered waste rock storage facility designs to remain stable, although the majority of the waste is to be stored temporarily. (low)

24.1.3 Underground Mining

Geotechnical analysis is required to confirm the proposed stope dimensions and sublevel heights, and to confirm that the backfill assumptions are reasonable for safe mining conditions. (medium)

The Mineral Resource in the underground mine plan consists of approximately 17% Indicated Mineral Resources and 83% Inferred Mineral Resources. Infill drilling is required to potentially convert Inferred to Indicated Mineral Resources and increase the confidence in the Mineral Resource Estimate. The drilling will confirm the historical chip samples from mining which are the basis of the estimate for most of the underground Inferred Mineral Resource. (medium)

The underground mine plan is based on adapting newer technology (i.e., Railveyor™) that, although used elsewhere, is not common in industry. (medium)

Hydrogeology is not well understood and requires study. Water re-charge rates are currently unknown. Previous studies show a substantially lower recharge rate than that assumed for pumping in this PEA. (low)

24.1.4 Processing Plant and Tailings

A toll roasting plant may not be available to accept concentrate feed from the Project. (high)

Estimated recoveries for the heap leach and process plant may differ than those assumed in this PEA, however, given the numerous studies conducted historically, the confidence of recoveries in the plant are reasonable. (low)

The dry stack tailings facility is located within the Hell Hollow drainage system which is a north-northwesterly trending canyon hosting intermittent streams that drain into the Merced River. (low)

24.1.5 Permitting

A Land Use Permit and accepted closure plan must be obtained from the County of Mariposa. (medium)

24.1.6 Financial Aspects

Financial viability of the Project is very dependent on the gold price. (medium)

24.2 OPPORTUNITIES

24.2.1 Mineral Resource Estimate

The Mineral Resource remains open along strike and down dip. There is an opportunity to extend the Deposit with additional drilling. (medium)

The oxide mineralization over the entire length of the Property is situated on top of the mineralized trend and has not been adequately drilled. There is potential to increase the quantity of heap leach material. (medium)

24.2.2 Mining and Processing Operations

Integrating the Railveyor™ into the open pit material handling configuration as already contemplated underground, and/or other electric-powered conveyor systems, may potentially improve efficiencies, reduce haulage distances, operating costs, reliance on haul trucks and related greenhouse gas emissions. (medium)

An increase in the open pit wall slopes through technical structural investigation would allow for increased open pit feed and improved economics. (medium)

Preliminary bioleaching studies completed in 1986 indicated competitive metal recoveries compared to roasting and should be further investigated for current oxide, quartz and SRM geometallurgical domains given advances in bioleach technology that have occurred in the 37 years since. Besides improved recoveries, advantages would include eliminating the use of cyanide, onsite versus offsite processing, transport costs and related traffic/greenhouse gas emissions, and roaster fees. (medium)

Further metallurgical work directed at specific geometallurgical domains identified in the Mineral Resource Estimate would serve to isolate graphitic preg-robbing domains, such as the Mariposa footwall sediments, for selective mining and processing so as not to contaminate less or non-refractory mineralized domains. (low)

Use of modern technology and automation is expected to improve efficiency and decrease operating costs. (low)

Evaluate and geospatially confirm historical underground openings such that the 3.1 m stand-off distance may be incorporated into the mine production. Historical workings could potentially be used as access, corridors for bulk material conveyor-type transport, and development infrastructure such as ventilation raises, production slot raises and passes. (low)

Use of electric equipment would reduce ventilation requirements in the underground and lower the overall environmental footprint by lowering greenhouse gas emissions. (low)

Investigate use of state-of-the-art passive and green power/EV technology such as solar and geothermal sources to reduce reliance on electrical grid, offset greenhouse gas emissions while in operations and potentially provide for post-operations sustainable power generation. (low)

Investigate waste rock materials as commercial aggregate by-products such as done by the Soledad Mountain gold mine in central California as well as many other mining operations world-wide. (low)

24.2.3 Financial Aspects

Gold is currently trading above the base case price of US\$1,750/oz used in the financial analysis. At a recent spot metal price of US\$2,000/oz Au, the Post-Tax NPV (using a discount rate of 5%) is estimated at \$370M with an IRR of 31%. (medium)

25.0 INTERPRETATION AND CONCLUSIONS

Stratabound's 100% owned Fremont Gold Property is located in Mariposa County, California, 20.3 km northwest of the Town of Mariposa, and approximately 241 km east of the City of San Francisco, in the western foothills of the Sierra Nevada Mountains. The Property consists of three Assessor Parcel Numbers totalling 3,351.22 acres (1,357 ha). The three APNs include mineral and surface rights and the land under State Highway 49, all of which are owned 100% by Fremont Gold Mining LLC., a wholly owned subsidiary of Stratabound, subject to a 3% NSR royalty.

The Fremont Property is readily accessible by California State Highway 49, which bisects the Property from north to south. A 70 kV power transmission line owned by PG&E crosses the Property from east to west. The local Bear Valley substation is located adjacent to Stratabound's office-warehouse, along Highway 49. Access and weather conditions allow for exploration and development work to be conducted year-round.

Regionally, the Fremont Property is located in the Mother Lode Gold District, which occurs in the southern portion of the western Sierra Nevada Foothills Metamorphic Belt. The Mother Lode Gold District occurs along the Melones Fault Zone, a major, crustal-scale fault trending north-northwesterly for 200 km. During the Early Cretaceous period, the Melones reverse fault system was reactivated in a transpressive regime, resulting in gold mineralization at approximately 125 ± 10 Ma. The Property geology is dominated by the Mariposa Formation metasedimentary and metavolcanic rocks to the west, the Melones Fault Zone in the centre, and the Bullion Mountain Formation metavolcanics and Briceburg Formation metasedimentary rocks and metavolcanics to the east. The Melones Fault Zone hosts the historical Pine Tree-Josephine Gold Deposit and the Queen Specimen Deposit. The Pine Tree-Josephine Deposit was mined from the 1850s to the 1940s via numerous shafts and underground drifts and produced at least 125,000 ounces of gold.

Three main styles of gold mineralization are present on the Fremont Property: 1) quartz hosted; 2) sulphide replacement; and 3) oxide cap mineralization. The quartz-hosted mineralization, represented primarily by the footwall and hanging wall veins and stockwork vein arrays locally in the footwall and hanging wall, consists primarily of free gold in quartz. The sulphide replacement mineralization occurs mainly in the tectonic melange between the footwall and hanging wall quartz veins. Gold occurs intergrown with pyrite and interstitial to quartz. The oxide gold mineralization occurs as a thin cap on the upper portions of the gold deposits. In the order of one-sixth to one-seventh of the upper portions of the deposits are variably oxidized and potentially amenable to cyanide heap leaching.

The gold deposits on the Fremont Property are hosted in metamorphosed volcanic and sedimentary rocks and associated with a major fault zone. They are therefore classified as orogenic mesothermal gold deposits.

Stratabound completed surface exploration activities in 2022, including compilation and reporting of a 2016-2017 property-wide soil geochemistry survey, and trenching, mine development activities and flying a LiDARTM topographic survey in 2022. Ten surface trenches were excavated at 50 m intervals across 500 m of strike overlying the Queen Specimen Deposit. This Deposit is the northernmost of four separately drilled gold-mineralized zones that are connected along 4 km of strike on surface by the >30 ppb gold in-soil anomaly. In addition to the current Mineral Resources, four Exploration Targets have been established for the Fremont Property, each with the

following potential characteristics: 1) Pine Tree-Josephine Extension at a range of 21 to 29 Mt and grade range of 1.8 g/t to 2.0 g/t Au; 2) Queen Specimen Extension at a range of 1 to 2 Mt and grade range of 1.1 g/t to 1.3 g/t Au; 3) Chicken Gulch at a range of 29 to 40 Mt and grade range of 0.4 g/t to 0.7 g/t Au; and 4) Crown Point at a range of 1 to 2 Mt and grade range of 0.3 g/t to 0.6 g/t Au. The Exploration Targets are based on the estimated strike length, depth and thickness of the known mineralization, which is supported by sparse drill holes and observations of mineralized surface exposures.

Stratabound has not completed any drilling on the Fremont Property. The most recent drilling programs were completed by California Gold Mining Inc. between 2013 and 2018. California Gold completed 82 surface diamond drill holes totalling 19,781 m. Of the 82 drill holes, 52 were completed into the Pine Tree-Josephine Deposit, 26 into the Queen Specimen Deposit, and four into the historical French Mine area. Historical 1985-1986 drilling results included 113 RC drill holes totalling 16,340 m on the Pine Tree-Josephine Deposit.

In the opinion of the Authors, the sample preparation, analytical procedures, security and QA/QC program meet industry standards, and that the data are of good quality and satisfactory for use in the Mineral Resource Estimate reported in this Technical Report. It is recommended that the Company continue with the current QC protocol, which includes the insertion of appropriate certified reference materials, blanks and duplicates. Due diligence sampling results show acceptable correlation with the original Company assays. In the Authors opinion, the drilling results are suitable for use in the current Mineral Resource Estimate.

The historical operations consistently achieved gold recoveries averaging 88.5% with a combined flotation and gravity circuit. Lock-cycle test results show a flotation recovery of 91.3% on a composite sample of Zones 5, 6 and 7. In June/July 1987, Beacon Hill achieved a flotation gold recovery of 89.7% on a composite underground bulk sample. For the 2014 iteration of test work, the samples were grouped by different metallurgical domains, including sulphide replacement material (“SRM”) and quartz (“QTZ”), for treatment by gravity and flotation. The 2014 combined gravity and flotation recovery for the SRM was 85.6% for gold and 69.1% for silver. The 2014 combined gravity and flotation recovery for the QTZ was 93.6% for gold and 75.6% for silver.

The flotation concentrate was not amenable to cyanidation without further processing. The roasting process was the most effective oxidation process evaluated for the recovery of gold. Roasting tests were not conducted on the SRM and QTZ samples. However, there has been extensive roasting test work completed and the cyanide leaching of the roasted product (calcine). The tests in a scoping work achieved 92.7% gold recovery and in a pilot campaign conducted at the Lurgi Plant in Frankfurt, Germany, achieved 90% gold recovery in cyanidation of the calcine.

A coarse bottle roll on oxide material (“OXC”) achieved a gold recovery of 93% in ten days of leaching -25.4 mm material, which confirms that the OXC has reasonable potential for heap leaching. Column leach tests on Zone 5, Zone 6, and Zone 7 oxide cap yielded gold recoveries of 88.1%, 78.8%, and 79.2%, respectively. Since each zone has an oxide cap on the surface, an average laboratory recovery of 82.0% is a reasonable starting point.

An updated Mineral Resource Estimate was prepared by the Authors for the Pine Tree-Josephine and Queen Specimen gold deposits. The updated Mineral Resource Estimate consists of a total of 1.163 Moz Au (19.01 Mt at 1.90 g/t Au) in Indicated Mineral Resources and 2.024 Moz (28.323

Mt at 2.22 g/t Au) in Inferred Mineral Resources. The pit-constrained Mineral Resources consist of 1.15 Moz Au in the Indicated classification and 1.49 Moz in the Inferred classification. The out-of-pit (underground) Mineral Resources consist of 9 koz Au in the Indicated classification and 536 koz Au in the Inferred classification.

The updated Mineral Resource Estimate is based on 33,982 m of drilling, 518 m of trench sampling, and 5,760 m of underground channel sampling. The effective date of the updated Mineral Resource Estimate is February 15, 2023. This updated Mineral Resource Estimate represents a 121% increase in the Indicated Mineral Resource classification and a 348% increase in the Inferred Mineral Classification since Stratabound acquired the Fremont Gold Project.

Pit-constrained Mineral Resources are reported using a cut-off grade of 0.25 g/t Au for oxide material and 0.45 g/t Au for sulphide material. Out-of-Pit (underground) Mineral Resources are reported using a cut-off grade of 1.45 g/t Au. Underground Mineral Resources have been constrained within potentially mineable longhole stoping shapes, based on block grade and continuity. Historical mining has been depleted from the Mineral Resource Estimate by assigning a zero-volume percentage block inclusion for known areas of mining and development.

The Mineral Resources presented in this Report were estimated using the Canadian Institute of Mining, Metallurgy and Petroleum (“CIM”), CIM Standards on Mineral Resources and Reserves, Definitions (2014) and Best Practices Guidelines (2019) prepared by the CIM Standing Committee on Reserve Definitions and adopted by the CIM Council. Mineral Resources, which are not Mineral Reserves, do not have demonstrated economic viability. The estimate of Mineral Resources may be materially affected by environmental, permitting, legal, title, taxation, socio-political, marketing, or other relevant issues. The Inferred Mineral Resource component of this estimate has a lower level of confidence than that applied to the Indicated Mineral Resource and must not be converted to a Mineral Reserve. It is reasonably expected that the majority of the Inferred Mineral Resource could be upgraded to an Indicated Mineral Resource with continued exploration.

The Property is four km along strike from north to south. The Deposits are open along strike and particularly down dip, and further drilling may provide additional Mineral Resources.

Mining will begin with three small oxide starter pits and heap leach in Year 1 concurrent with initial Pine Tree-Josephine open pit phase 1. The oxide heap leach pad is planned to be constructed within the tailings facility to minimize Project footprint and use a common liner.

The three-phased Pine Tree-Josephine open pit is planned for a production rate of 6,000 tonnes per day to provide low-cost production and generate early cash flow while the construction and development of the underground operation starts in Year 2.

Upon completion of the Pine Tree-Josephine open pit in Year 4, the Queen Specimen open pit is planned to be developed to supplement underground production to feed the process plant at a rate of 750 kt per year. The open pits will be backfilled with waste rock after mining is completed. There will be opportunity for progressive reclamation over the life of the mine.

The Pine Tree-Josephine underground mine is planned for a production rate of 4,000 tpd. The selected mining method is longhole open stoping with both longitudinal retreat and transverse

mining, depending on the vein thickness. Stopes will be filled with cemented paste backfill. Stope dimensions will average 10 m in strike length and 30 m in height, with a minimum thickness of four m. Mineralized material will be extracted using a fleet of 10-tonne load-haul-dump units that will tip material down a broken material pass to a Railveyor™ system on a main haulage level. The Railveyor™ will transport material to the process plant via the portal and up a surface hillside.

The underground mine will have its own ventilation, electrical, and dewatering systems.

Both open pit and underground mining and development will be performed by Company personnel, with a leased fleet.

A total of 6,000 tpd of material will be treated in a process plant that consists of three-stage crushing, followed by a grinding circuit consisting of a ball mill. A gravity circuit will recover coarse gold from the process plant feed, which then flows on to rougher flotation cells creating a sulphide concentrate containing the gold. The concentrate will be reground and floated in cleaner cells where the clean concentrate and gravity concentrate will be filtered and bagged for shipping to a roaster offsite.

For the first year of operation, a heap leach plant will be built to recover the gold in carbon from the heap leach pad that will be constructed in the tailings facility to minimize footprint and maximize use of liner construction.

The process plant is followed by a tailings filtration plant with a filter press to produce paste backfill to send underground and/or to produce dry stack tailings for surface storage. For this study, a flotation plant recovery of 92% gold to concentrate was utilized. At the offsite roaster, 82% of the gold contained in concentrate is estimated to be payable, including processing charges.

The Fremont Gold Project is planned to produce 22.3 Mt of mineralized material at a nominal production rate of 6,000 tpd and an average grade of 2.4 g/t Au over an 11-year mine life. Production from open pit mining will consist of 7.91 Mt of the mine plan portion of the Indicated Mineral Resource at 1.82 g/t Au and 2.55 Mt of the mine plan portion of the Inferred Mineral Resource at 1.31 g/t Au. Production from the underground mine plan will consist of 1.89 Mt of Indicated Mineral Resource at 3.14 g/t Au and 9.51 Mt of Inferred Mineral Resource at 3.12 g/t Au. Total contained gold is estimated at 1,727 koz and the LOM amount of gold recovered after toll roaster processing is estimated at 1,303 koz.

The Property is serviced by paved, all-weather Highway 49 which bisects the Property, secondary access roads, and PG&E power line and transformer station on site. An office/core logging facility is also on site. Site infrastructure will include an administration office building, change house facility, 6,000 tpd processing plant, pastefill/tailings filtration plant, filtered tailings management facility, laboratory and surface workshop. The underground mine will include two portals and a Railveyor™ system. There will be no camp, and employees will be expected to travel from nearby communities.

There are currently no material contracts in place pertaining to the Fremont Gold Project. The Project is open to the spot gold price market and there are no streaming or forward sales contracts in place. The Authors of this Technical Report used the rounded, approximate 3-year average monthly trailing gold price as of September 30, 2022 of US\$1,750/oz for this PEA.

The Fremont Project is located in Mariposa County on private land and, therefore is subject to California Environmental Quality Assurance process Surface Mining and Reclamation Act. A Conditional Use Permit ("CUP") and approved closure plan will be sought from the County following the completion of the Environmental Impact Report and Closure Plan acceptance. In addition to CUP and closure plan approval, the Project will require permits and authorizations prior to construction and operation of the mine. A Closure Plan, and associated financial assurance, will be prepared by Fremont and submitted to the government for filing before development of the Project commences. The mine closure cost is currently estimated at \$30M.

Initial capital costs for site preparation, surface infrastructure, a process plant, backfill plant, tailings facility, mining equipment lease down payments, and surface mining pre-stripping are estimated at \$203M and include a 15% contingency. Sustaining capital costs over the LOM are estimated at \$283M, mainly for mining equipment leases and underground mine development.

Operating costs for surface mining, underground mining, heap leach processing, flotation processing, concentrate transport and G&A are estimated to average \$52.05/t and total \$1,163M over the LOM.

The Project is subject to NSR royalties of 3% and total costs are estimated at \$68.4M over the LOM.

Cash costs over the LOM, including royalties, are estimated to average \$924/oz of gold. All-In Sustaining Costs ("AISC") over the LOM are estimated to average \$1,162/oz of gold and include closure costs.

At a 5% discount rate and US\$1,750/oz gold price the post-tax NPV of the Project is estimated at \$217M (\$328M pre-tax), with an IRR of 21.4% (28.6% pre-tax). This results in a payback period of approximately 4.2 years. The Project NPV is most sensitive to factors affecting revenue from gold production, such as: gold price, processing recovery, and payable gold factor (value of gold in concentrate less toll roasting charges).

26.0 RECOMMENDATIONS

The Authors of this Technical Report consider that the Fremont Gold Project contains a significant gold Mineral Resource base that merits further evaluation. This PEA shows potential economic viability for an open pit and underground mining and processing plan, yet much may still be done that would enhance these economics. Significant technical improvements to the PEA economics, would include in order of impact:

1. Increase in oxide/heap leach amenable Mineral Resources;
2. Increase in open pit and underground Mineral Resources through definition drilling potential along remaining undefined 65% of strike and potential parallel zones;
3. Increase in pit wall slope through technical structural investigation;
4. Further optimized mine designs and scheduling;
5. Integrate RailveyorTM, or other industry-standard conveying system, into open pit materials handling configuration;
6. Increase in underground head grade through further cut-off grade analysis;
7. Investigate waste materials as commercial aggregate by-products such as that done already by Soledad Mountain gold mine in central California as well as many other mining operations world-wide;
8. Investigate options and alternatives to refractory processing using green and other state-of-the-art technologies;
9. Use of historical underground workings as access, bulk material conveyor-type transport, and development infrastructure such as ventilation raises, production slot raises and passes;
10. Use of state-of-the-art passive and green power/EV technology to offset electrical requirements as well as mitigate and reduce greenhouse gas emission footprint; and
11. Enhance the long-term real estate value beyond the mine life through progressive and post-mining re-purposing of the Property for recreation, community, environmental, social, and commercial uses.

The Authors recommend advancing the Project in a two-phase approach. The first phase of activity would have the objective of building upon the oxide and adjacent near-surface Inferred Mineral Resources for inclusion into an updated Mineral Resource Estimate and a potentially economically improved PEA. Further drilling is also recommended in the first phase to follow up on the continuous, four-kilometre-long soil anomaly which is coincident with the two deposits and the two additional Crown Point and Chicken Gulch mineralized zones. The second phase would advance the Project to the Pre-Feasibility Study level of confidence and is not contingent on the success of the first phase. The second phase would include infill drilling to upgrade Inferred to the

Indicated and Measured Resource classifications, a bulk sample, metallurgical, geotechnical, hydrogeological, permitting, environmental studies and community engagement activities. Drilling in all phases would additionally consider groundwater and hydrogeological investigation and geotechnical analysis.

The Phase 1 activities would include:

1. Systematic mapping and sampling of the trenches and road cuts overlying the mineral domains where exposed at surface;
2. Shallow RC drilling (~2,000 m, 100 m sections) to evaluate the open at-surface and sub-surface undefined oxide potential immediately overlying and to the west of the current defined oxide domains. The majority of drilling to date defining the current oxide zone was collared well away to the east from the mineralization and remains open and undefined where it projects to surface on the west;
3. Shallow RC drilling (~3,000 m, 100 m sections) through oxide potential into shallow primary sulphide and quartz vein potential across and between the full remaining untested 2,500 m strike extent;
4. Close-spaced RC drilling (~300 m) in advance of a second phase approximate 100,000 t bulk sample of all mineralization types, not to exceed one acre (4,047 m²) in area so as to remain within the regulatory threshold requirements of the Mariposa County Conditional Use Permit authorization for exploration purposes. The bulk sample will address items 3), 6), and 8) in the page above for numerous studies including metallurgical, waste by-product/aggregate characterization, structural slope stability, and block model/Mineral Resource Estimate reconciliation analyses studies; and
5. Step-out diamond drilling (~1,500 m) along 250 m at both ends of the current mineralized domain strike limits.

All drilling activities would consider groundwater and structural investigation as additional key objectives.

It is recommended that Stratabound continue with the current QC protocol, which includes the insertion of certified reference materials, blanks and duplicates, and to further support this protocol with umpire assaying (on at least 5% of samples) at a reputable secondary laboratory. It is further recommended that a rigorous program of collecting bulk density measurements continue to be implemented and selected oriented drill core structural investigation be done.

In addition to Mineral Resource classification upgrades, in-fill drilling should consider accurately defining the historical underground workings through Cavity Monitoring Survey (“CMS”) downhole tools as well as oriented core work for structural studies such that the historical workings may be utilized and incorporated into the mine plan as access, bulk material conveyor-type transport, and development infrastructure such as ventilation raises, production slot raises and passes. UAV drone surveys are now industry standard and may also have an application.

Additional metallurgical, paste backfill and concentrate test work is warranted to evaluate optimum grinding and recovery parameters. It will also provide concentrate samples for the evaluation of toll processing. It is recommended that the following series of tests be conducted on representative samples of each geological domain (OXC, SRM, and QTZ). Given the size of the Mineral Resource, it is recommended that multiple composites of each geological domain are collected, possibly broken down by location (East, West, etc.) or depth. The series includes:

1. Confirmation lock-cycle flotation and gravity tests on SRM and QTZ composites;
2. Flotation tests utilizing the expected water source from site to ensure there are no chemistry concerns;
3. Column leach test work on OXC material at multiple crush sizes, including washing and rinsing;
4. Roasting tests on the flotation concentrate from SRM and QTZ samples;
5. Crushing and abrasion index tests on each domain;
6. Filtration testing on flotation tailings and concentrates;
7. Meteoric Water Mobility Tests or Toxicity Characteristic Leaching Procedure tests on flotation tails, as required by California; and
8. Humidity cell tests on flotation tails for each domain.

Additional geochemical characterization work should be completed on waste rock and mineralized material to inform future water and material handling and management plans.

To support the development of the underground workings, it is recommended that a numerical groundwater model be developed to predict inflow rates into the proposed underground workings and to further characterize the potential impacts. The results of the numerical modelling will also support future permitting activities and design of the water management infrastructure. A site water management plan should be developed as part of future engineering studies on the Project.

The Company commenced permitting and baseline environmental studies in 2022 and these should continue to be conducted since they require multi-year and seasonal data to support ongoing permitting activities including surface water quality and quantity, groundwater quality, terrestrial, and aquatic baseline studies.

The Company should continue to consult and engage with stakeholders and Indigenous groups on the Project to keep them informed, engaged and part of the solutions to local issues where appropriate.

Multiple scenarios were investigated to optimize the value of the Fremont underground mine plan. While the RailveyorTM was determined to be the optimal solution at this stage of the Project, the Authors recommend that future studies investigate the potential for possible use of existing infrastructure for materials handling.

A recommended \$22M work program is proposed in Table 26.1.

TABLE 26.1			
RECOMMENDED WORK PROGRAM AND BUDGET			
Program	Units (m)	Unit Cost (\$/m)	Budget (\$M)
Phase One: Define Near-Surface Inferred Mineral Resource Potential			
Surface Trench Sampling			0.2
RC Drilling Oxide West of Mineral Resource	2,000	150	0.3
RC Drilling Step-out (100 m Sections)	3,300	150	0.5
Step-Out Diamond Drilling – 0.5 km Strike	1,500	200	0.3
Mineral Resource and PEA Updates			0.3
Subtotal Phase One			1.6
Phase Two:			
Bulk Sample (100 kt @ \$7/tonne)			0.7
In-fill Diamond Drilling (to Indicated)	20,000	200	4.0
Step-Out and Exploration Diamond Drilling	20,000	200	4.0
Geotechnical and Hydrology Studies			1.0
Metallurgical Test work			0.3
Permitting and Environmental Studies			5.0
Pre-Feasibility Study			2.5
Subtotal Phase Two			17.5
Contingency (15%)			3.0
Total			22.1

27.0 REFERENCES

- Bacon, Donaldson & Associates. 1986. Leaching Test Work on the Pine Tree oxide materials. Report No. 22.
- Beacon Hill. 1988. Conceptual Plan for the Underground Mining of the Pine Tree-Josephine Deposit, Mariposa County, California, U.S.A. Prepared for ABM Gold Corp. by W.P. Stokes and B.M. Briggs of Beacon Hill Consultants Ltd. Dated December 5, 1988. 97 p.
- Beacon Hill. 1991. Pine Tree Project, Mariposa County, California: Project Development Report. Prepared for NorthWest Gold Corp. by Beacon Hill Consultants Ltd. (Mining Engineers & Geologists). Dated April 1991. 228 p.
- Bohlke, J.K. and Kistler, R.W. 1986. Rb-Sr, K-Ar, and Stable Isotope Evidence for the Ages and Sources of Fluid Components of Gold-Bearing Quartz Veins in the Northern Sierra Nevada Foothills Metamorphic Belt, California. *Economic Geology* 81, 296-322.
- Bowen, O.E., Jr. and Gray, C.H., Jr. 1957. Mines and Mineral Deposits of Mariposa County, California. *California Journal of Mines and Geology* 53, (1-2).
- Burgoyne. 2013. Technical Report for the Las Mariposas Ranch Property (also known as the Fremont Property), Mariposa County, California. Prepared for California Gold Mining Inc. (formerly Upper Canada Gold Corporation) by A.A. Burgoyne of Burgoyne Geological Inc. Consulting Geologists & Engineers. Signing date June 12, 2013 (effective date May 7, 2013). 102 pages.
- Burstow. W.D. 1986. Surficial Geology of the Pinetree Project, Mariposa County, California. Prepared for Golden Bell Mining Corporation by William D. Burstow of Ager, Berretta & Ellis Inc. 13 pages.
- Campo, A. 2022. Pine Tree-Josephine Drill Road Sample – May 2022. Internal Report to Stratabound Mineral Corp., 2 pages
- Cedar Creek Associates, 1987: Reclamation Plan for the Pine Tree Project, Goldenbell Mining Corporation, September 1987.
- Champigny, N. 1984. Bore Hole Spacing Optimization and Calculation of Geological Reserves, of the Pinetree Gold Deposit, California for ABM Mining Group, International Geosystems Corporation, September 6, 1984.
- Canadian Institute of Mining, Metallurgy and Petroleum (CIM). 2014. CIM Definition Standards for Mineral Resources and Mineral Reserves adopted by CIM Council on May 10, 2014.
- Canadian Institute of Mining, Metallurgy and Petroleum (CIM). 2019. CIM Estimation of Mineral Resources and Mineral Reserves Best Practice Guidelines adopted by the CIM Council on November 29, 2019.

- DMBW. 1988. Geologic Reserve Study, Goldenbell Property, Mariposa County, California. Prepared for Goldenbell Mining Corp. by I.S. Parrish and T.V. Mullen of Derry, Michner, Booth & Wahl, Inc. Dated May 6, 1988. 38 pages.
- Faverty & Associates. 1988. Comments and Responses to the Draft Environmental Impact Report, Pine Tree Project, Goldenbell Mining Corporation, March 1988.
- Faverty & Associates. 1987. Draft Environmental Impact Report, Pine Tree Project. Goldenbell Mining Corporation, September 1987.
- Ford, G. 1988. Bulk Sampling – Pine Tree Adit. Prepared for Goldenbell Mining Corp. by Gordon Ford of ABM Mining Group. 52 pages.
- Ford, G. and Cochrane, D. 1984. Goldenbell Resources Incorporated, Pinetree Project Area, Mariposa County, California. Dated December 13, 1984.
- GeoFocus Mapping Inc. 2022. Fremont LiDAR 2022. Internal Report for Stratabound Minerals Corp. dated June 2022. 2 pages.
- Geotech. 2015. Report on a Helicopter-Borne Gamma-Ray and Aeromagnetic Geophysical Survey. Internal report prepared for Fremont Gold Inc. by Geotech Ltd., dated October 2015.
35 pages.
- Golder Associates, 1988. Compilation of Geotechnical Reports Prepared by Golder Associates for Goldenbell Resources Incorporated, Re Pine Tree Project, Mariposa County California.
- Goldfarb, R.J. and Groves, D.I. 2015. Orogenic Gold: Common or Evolving Fluid and Metal Sources Through Time. *Lithos* 233, 2-26.
- Groves, D.I. and Santosh, M. 2016. The giant Jiadong Gold Province: The Key to a Unified Model for Orogenic Gold Deposits? *Geoscience Frontiers* 7, 409-417.
- Inspectorate. 2014. Metallurgical Testing of Samples from the Fremont Project, California. Prepared for Fremont Gold Mining LLC by Alice Shi and Michael Redfearn, Metallurgical Division, Inspectorate Exploration & Mining Services Ltd. Date: August 19, 2014. 95 pages.
- Kikauka, A. 2003. Goldenbell Mining Corp. 1985 Geophysical and Geochemical Data, Pine Tree Project – Mariposa County, California, USA for Goldrea Resources Corp. Dated March 30, 2003.
- McAllister, C.A. 1990. The Pine Tree and Josephine Mine of the Southern Mother Lode, Mariposa County, California: Mining History, Geology, and Fluid Inclusion Study Applied to Gold Exploration. M.Sc. Thesis, School of Natural Sciences, California State University, Fresno. Dated December 1990. 78 pages.

- Northwest Gold Corp. 1988. Internally Generated Estimates Based on DMBW (Mullen and Parrish), 1988.
- Payne, M. 2014. Pine Tree-Josephine Project, Mariposa Co., Calif. Progress Report Summary Drill Hole Geology and Assays. Prepared for Fremont Gold Mining LLC. 14 pages.
- Pohlmann, R. 2016. Fremont Soil Sample Project, Mariposa County, California. Internal Report for California Gold Mining Inc. Prepared by Pohlmann, R. of North American Exploration Inc. 4 pages.
- Pohlman, R. 2017. Fremont Soil Sample Project, Mariposa County, California. Internal Report for California Gold Mining Inc. Prepared by Pohlmann, R. of North American Exploration Inc. 5 pages.
- Robb, L. 2005. Introduction to Ore-Forming Processes. Blackwell Publishing, 373 pages.
- RPA. 2016. Technical Report on the Fremont Gold Project, Mariposa County, State of California, U.S.A. Prepared for California Gold Mining Inc. by Tudorel Ciuculescu of Roscoe Postle Associates Inc. Signing date December 9, 2016. 108 pages.
- Shonk, K. 2011. Preliminary Summary Report on the Pine Tree-Josephine Gold Property, Mariposa County, California, dated June 22, 2008 and revised April 11, 2011.
- Sillitoe, R.H. 2008. Major Gold Deposits and Belts of the North and South American Cordillera: Distribution, Tectonomagmatic Setting, and Metallurgical Considerations. Economic Geology 103, 663-687.
- SLR. 2021. Technical Report on the Fremont Gold Project, Central California, USA. Prepared for Stratabound Minerals Corp. by Tudorel Ciuculescu of SLR Consulting (Canada) Ltd. Signing date September 30, 2021 (effective date August 31, 2021). 101 pages.
- Smith, R. 2008. Summary of Drilling Program and Resource Evaluation Report: Pine Tree Mine Tailings, Mariposa County, California. Prepared for Global Mining Explorations Ventures LLC by Roger Smith. Dated October 2008. 88 pages.
- Snow, C.A. and Scherer, H. 2006. Terranes of the Western Sierra Nevada Foothills Metamorphic Belt, California: A Critical Review. International Geology Review 48, 46-62.
- SRK. 2014. Structural Geology Investigation of the Fremont Property, Mariposa County, California, USA. Prepared for Fremont Gold Mining LLC by SRK Consulting.
- SRK. 2015. Technical Memorandum – Fremont Project – Geophysical Interpretation. Internal Report prepared for Fremont Gold Mining LLC by SRK Consulting, dated December 11, 2015. 20 pages.

Wright Engineers Ltd. 1986. Feasibility Study. Volumes include:

- Project Description, March 26, 1986
- Geological Reserve Estimate, October 21, 1986
- Executive Summary, November 1986
- Property Valuation, November 1986
- Technical Summary, November 1986
- Vol. I - Technical Report, November 1986
- Vol. II - Financial Analysis, November 1986
- Vol. III – Drawings, November 1986
- Vol. IV – Appendices 1 through 7, November 1986
- Vol. IV – Appendix 8, Metallurgical Test Reports – Test Book #1
- Vol. IV – Appendix 8, Metallurgical Test Results – Book #2

Wright Engineers Ltd. 1988. Basic Design Report (2 volumes) by Wright Engineers Ltd. & The Industrial Company. Dated February 1988.

Wright Engineers Ltd. 1989. Heap Leach Pre-feasibility Study by Wright Engineers Ltd. Dated January 1989.

28.0 CERTIFICATES

CERTIFICATE OF QUALIFIED PERSON

ANDREW BRADFIELD, P. ENG.

I, Andrew Bradfield, P. Eng., residing at 5 Patrick Drive, Erin, Ontario, N0B 1T0, do hereby certify that:

1. I am an independent mining engineer contracted by P&E Mining Consultants.
2. This certificate applies to the Technical Report titled “Preliminary Economic Assessment of the Fremont Gold Project, Mariposa County, Central California, USA”, (The “Technical Report”) with an effective date of February 15, 2023.
3. I am a graduate of Queen’s University, with an honours B.Sc. degree in Mining Engineering in 1982. I have practiced my profession continuously since 1982. I am a Professional Engineer of Ontario (License No.4894507). I am also a member of the National CIM.

I have read the definition of “Qualified Person” set out in National Instrument 43-101 (“NI 43-101”) and certify that, by reason of my education, affiliation with a professional association (as defined in NI 43-101) and past relevant work experience, I fulfill the requirements to be a “Qualified Person” for the purposes of NI 43-101.

I have practiced my profession continuously since 1982. My summarized career experience is as follows:

- Various Engineering Positions – Palabora Mining Company, 1982-1986
- Mines Project Engineer – Falconbridge Limited, 1986-1987
- Senior Mining Engineer – William Hill Mining Consultants Limited, 1987-1990
- Independent Mining Engineer, 1990-1991
- GM Toronto – Bharti Engineering Associates Inc, 1991-1996
- VP Technical Services, GM of Australian Operations – William Resources Inc, 1996-1999
- Independent Mining Engineer, 1999-2001
- Principal Mining Engineer – SRK Consulting, 2001-2003
- COO – China Diamond Corp, 2003-2006
- VP Operations – TVI Pacific Inc, 2006-2008
- COO – Avion Gold Corporation, 2008-2012
- Independent Mining Engineer, 2012-Present

4. I have not visited the Property that is the subject of this Technical Report.
5. I am responsible for authoring Sections 2, 3, 15, 19, 22 and 24, and co-authoring Sections 1, 16, 21, 25, 26 and 27 of this Technical Report.
6. I am independent of the Issuer applying the test in Section 1.5 of NI 43-101. I am independent of the Vendor and the Property.
7. I have had no prior involvement with the Project that is the subject of this Technical Report.
8. I have read NI 43-101 and Form 43-101F1. This Technical Report has been prepared in compliance therewith.
9. As of the effective date of this Technical Report, to the best of my knowledge, information and belief, the Technical Report contains all scientific and technical information that is required to be disclosed to make the Technical Report not misleading.

Effective Date: February 15, 2023

Signing Date: March 31, 2023

{SIGNED AND SEALED}

[Andrew Bradfield]

Andrew Bradfield, P.Eng.

CERTIFICATE OF QUALIFIED PERSON

JARITA BARRY, P.GEO.

I, Jarita Barry, P.Geo., residing at 9052 Mortlake-Ararat Road, Ararat, Victoria, Australia, 3377, do hereby certify that:

1. I am an independent geological consultant contracted by P&E Mining Consultants Inc.
2. This certificate applies to the Technical Report titled “Preliminary Economic Assessment of the Fremont Gold Project, Mariposa County, Central California, USA”, (The “Technical Report”) with an effective date of February 15, 2023.
3. I am a graduate of RMIT University of Melbourne, Victoria, Australia, with a B.Sc. in Applied Geology. I have worked as a geologist for over 17 years since obtaining my B.Sc. degree. I am a geological consultant currently licensed by Engineers and Geoscientists British Columbia (License No. 40875) and Professional Engineers and Geoscientists Newfoundland & Labrador (License No. 08399). I am also a member of the Australasian Institute of Mining and Metallurgy of Australia (Member No. 305397).

I have read the definition of “Qualified Person” set out in National Instrument 43-101 (“NI 43-101”) and certify that by reason of my education, affiliation with a professional association (as defined in NI 43-101) and past relevant work experience, I fulfill the requirements to be a “Qualified Person” for the purposes of NI 43-101.

My relevant experience for the purpose of the Technical Report is:

- Geologist, Foran Mining Corp. 2004
- Geologist, Aurelian Resources Inc. 2004
- Geologist, Linear Gold Corp. 2005-2006
- Geologist, Búscore Consulting 2006-2007
- Consulting Geologist (AusIMM) 2008-2014
- Consulting Geologist, P.Geo. (EGBC/AusIMM) 2014-Present

4. I have not visited the Property that is the subject of this Technical Report.
5. I am responsible for authoring Section 11 and co-authoring Sections 1, 12, 25, 26 and 27 of this Technical Report.
6. I am independent of the Issuer applying the test in Section 1.5 of NI 43-101.
7. I have had prior involvement with the Project that is the subject of this Technical Report. I was a “Qualified Person” for a Technical Report titled “Technical Report and Updated Mineral Resource Estimate of the Pine Tree-Josephine and Queen Specimen Deposits, Fremont Gold Project, Mariposa County, Central California, USA”, with an effective date of June 30, 2022.
8. I have read NI 43-101 and Form 43-101F1 and the Technical Report has been prepared in compliance therewith.
9. As of the effective date of this Technical Report, to the best of my knowledge, information and belief, the Technical Report contains all scientific and technical information that is required to be disclosed to make the Technical Report not misleading.

Effective Date: February 15, 2023

Signing Date: March 31, 2023

{SIGNED AND SEALED}

[Jarita Barry]

Jarita Barry, P.Geo.

CERTIFICATE OF QUALIFIED PERSON

FRED H. BROWN, P.GEO.

I, Fred H. Brown, of PO Box 332, Lynden, WA, USA, do hereby certify that:

1. I am an independent geological consultant and have worked as a geologist continuously since my graduation from university in 1987.
2. This certificate applies to the Technical Report titled “Preliminary Economic Assessment of the Fremont Gold Project, Mariposa County, Central California, USA”, (The “Technical Report”) with an effective date of February 15, 2023.
3. I graduated with a Bachelor of Science degree in Geology from New Mexico State University in 1987. I obtained a Graduate Diploma in Engineering (Mining) in 1997 from the University of the Witwatersrand and a Master of Science in Engineering (Civil) from the University of the Witwatersrand in 2005. I am registered with the Association of Professional Engineers and Geoscientists of British Columbia as a Professional Geoscientist (171602) and the Society for Mining, Metallurgy and Exploration as a Registered Member (#4152172).

I have read the definition of “Qualified Person” set out in National Instrument 43-101 (“NI 43-101”) and certify that, by reason of my education, affiliation with a professional association (as defined in NI 43-101) and past relevant work experience, I fulfill the requirements to be a “Qualified Person” for the purposes of NI 43-101.

My relevant experience for the purpose of the Technical Report is:

- Underground Mine Geologist, Freegold Mine, AAC 1987-1995
- Mineral Resource Manager, Vaal Reefs Mine, AngloGold 1995-1997
- Resident Geologist, Venetia Mine, De Beers 1997-2000
- Chief Geologist, De Beers Consolidated Mines 2000-2004
- Consulting Geologist 2004-2008
- P&E Mining Consultants Inc. – Sr. Associate Geologist 2008-Present

4. I have visited the Property that is the subject of this Technical Report on March 24 and 25, 2022.
5. I am responsible for co-authoring Sections 1, 12, 14, 25, 26 and 27 of this Technical Report.
6. I am independent of the Issuer applying the test in Section 1.5 of NI 43-101.
7. I have had prior involvement with the Project that is the subject of this Technical Report. I was a “Qualified Person” for a Technical Report titled “Technical Report and Updated Mineral Resource Estimate of the Pine Tree-Josephine and Queen Specimen Deposits, Fremont Gold Project, Mariposa County, Central California, USA”, with an effective date of June 30, 2022.
8. I have read NI 43-101 and Form 43-101F1 and this Technical Report has been prepared in compliance therewith.
9. As of the effective date of this Technical Report, to the best of my knowledge, information and belief, the Technical Report contains all scientific and technical information that is required to be disclosed to make the Technical Report not misleading.

Effective Date: February 15, 2023

Signing Date: March 31, 2023

{SIGNED AND SEALED}

[Fred H. Brown]

Fred H. Brown, P.Geo.

CERTIFICATE OF QUALIFIED PERSON

D. GRANT FEASBY, P. ENG.

I, D. Grant Feasby, P. Eng., residing at 12,209 Hwy 38, Tichborne, Ontario, K0H 2V0, do hereby certify that:

1. I am currently the Owner and President of:
FEAS - Feasby Environmental Advantage Services
38 Gwynne Ave, Ottawa, K1Y1W9
2. This certificate applies to the Technical Report titled “Preliminary Economic Assessment of the Fremont Gold Project, Mariposa County, Central California, USA”, (The “Technical Report”) with an effective date of February 15, 2023.
3. I graduated from Queens University in Kingston Ontario, in 1964 with a Bachelor of Applied Science in Metallurgical Engineering, and a Master of Applied Science in Metallurgical Engineering in 1966. I am a Professional Engineer registered with Professional Engineers Ontario. I have worked as a metallurgical engineer for over 50 years since my graduation from university.

I have read the definition of “Qualified Person” set out in National Instrument 43-101 (“NI 43-101”) and certify that by reason of my education, affiliation with a professional association (as defined in NI 43-101) and past relevant work experience, I fulfill the requirements to be a “Qualified Person” for the purposes of NI 43-101.

My relevant experience for the purpose of the Technical Report has been acquired by the following activities:

- Metallurgist, Base Metal Processing Plant.
- Research Engineer and Lab Manager, Industrial Minerals Laboratories in USA and Canada.
- Research Engineer, Metallurgist and Plant Manager in the Canadian Uranium Industry.
- Manager of Canadian National Programs on Uranium and Acid Generating Mine Tailings.
- Director, Environment, Canadian Mineral Research Laboratory.
- Senior Technical Manager, for large gold and bauxite mining operations in South America.
- Expert Independent Consultant associated with several companies, including P&E Mining Consultants, on mineral processing, environmental management, and mineral-based radiation assessment.

4. I have not visited the Property that is the subject of this Technical Report.
5. I am responsible for authoring Section 20 and co-authoring Sections 1, 25, 26 and 27 of this Technical Report.
6. I am independent of the issuer applying the test in Section 1.5 of NI 43-101.
7. I have had prior involvement with the Project that is the subject of this Technical Report. I was a “Qualified Person” for a Technical Report titled “Technical Report and Updated Mineral Resource Estimate of the Pine Tree-Josephine and Queen Specimen Deposits, Fremont Gold Project, Mariposa County, Central California, USA”, with an effective date of June 30, 2022.
8. I have read NI 43-101 and Form 43-101F1 and the Technical Report has been prepared in compliance therewith.
9. As of the effective date of this Technical Report, to the best of my knowledge, information and belief, the Technical Report contains all scientific and technical information that is required to be disclosed to make the Technical Report not misleading.

Effective Date: February 15, 2023

Signing Date: March 31, 2023

{SIGNED AND SEALED}

[D. Grant Feasby]

D. Grant Feasby, P.Eng.

CERTIFICATE OF QUALIFIED PERSON

EUGENE PURITCH, P. ENG., FEC, CET

I, Eugene J. Puritch, P. Eng., FEC, CET, residing at 44 Turtlecreek Blvd., Brampton, Ontario, L6W 3X7, do hereby certify that:

1. I am an independent mining consultant and President of P&E Mining Consultants Inc.
2. This certificate applies to the Technical Report titled “Preliminary Economic Assessment of the Fremont Gold Project, Mariposa County, Central California, USA”, (The “Technical Report”) with an effective date of February 15, 2023.
3. I am a graduate of The Haileybury School of Mines, with a Technologist Diploma in Mining, as well as obtaining an additional year of undergraduate education in Mine Engineering at Queen’s University. In addition, I have also met the Professional Engineers of Ontario Academic Requirement Committee’s Examination requirement for a Bachelor degree in Engineering Equivalency. I am a mining consultant currently licensed by the: Professional Engineers and Geoscientists New Brunswick (License No. 4778); Professional Engineers, Geoscientists Newfoundland and Labrador (License No. 5998); Association of Professional Engineers and Geoscientists Saskatchewan (License No. 16216); Ontario Association of Certified Engineering Technicians and Technologists (License No. 45252); Professional Engineers of Ontario (License No. 100014010); Association of Professional Engineers and Geoscientists of British Columbia (License No. 42912); and Northwest Territories and Nunavut Association of Professional Engineers and Geoscientists (No. L3877). I am also a member of the National Canadian Institute of Mining and Metallurgy.

I have read the definition of “Qualified Person” set out in National Instrument 43-101 (“NI 43-101”) and certify that, by reason of my education, affiliation with a professional association (as defined in NI 43-101) and past relevant work experience, I fulfill the requirements to be a “Qualified Person” for the purposes of NI 43-101.

I have practiced my profession continuously since 1978. My summarized career experience is as follows:

- Mining Technologist - H.B.M. & S. and Inco Ltd., 1978-1980
- Open Pit Mine Engineer – Cassiar Asbestos/Brinco Ltd., 1981-1983
- Pit Engineer/Drill & Blast Supervisor – Detour Lake Mine, 1984-1986
- Self-Employed Mining Consultant – Timmins Area, 1987-1988
- Mine Designer/Resource Estimator – Dynatec/CMD/Bharti, 1989-1995
- Self-Employed Mining Consultant/Resource-Reserve Estimator, 1995-2004
- President – P&E Mining Consultants Inc, 2004-Present

4. I have not visited the Property that is the subject of this Technical Report.
5. I am responsible for co-authoring Sections 1, 14, 25, 26 and 27 of this Technical Report.
6. I am independent of the Issuer applying the test in Section 1.5 of NI 43-101.
7. I have had prior involvement with the Project that is the subject of this Technical Report. I was a “Qualified Person” for a Technical Report titled “Technical Report and Updated Mineral Resource Estimate of the Pine Tree-Josephine and Queen Specimen Deposits, Fremont Gold Project, Mariposa County, Central California, USA”, with an effective date of June 30, 2022.
8. I have read NI 43-101 and Form 43-101F1. This Technical Report has been prepared in compliance therewith.
9. As of the effective date of this Technical Report, to the best of my knowledge, information and belief, the Technical Report contains all scientific and technical information that is required to be disclosed to make the Technical Report not misleading.

Effective Date: February 15, 2023

Signing Date: March 31, 2023

{SIGNED AND SEALED}

[Eugene Puritch]

Eugene Puritch, P.Eng., FEC, CET

CERTIFICATE OF QUALIFIED PERSON

GREG ROBINSON, P. ENG.

I, David Gregory (Greg) Robinson, P. Eng. (ON), residing at 1236 Sandy Bay Road, Minden, ON, K0M 2K0, do hereby certify that:

1. I am an independent engineering consultant working for P&E Mining Consultants Inc.
2. This certificate applies to the Technical Report titled “Preliminary Economic Assessment of the Fremont Gold Project, Mariposa County, Central California, USA”, (The “Technical Report”) with an effective date of February 15, 2023.
3. I am a graduate of Dalhousie University, Queens University and Cornell University, and Professional Engineer of Ontario (License No. 100216726).

I have read the definition of “Qualified Person” set out in National Instrument 43-101 (“NI 43-101”) and certify that, by reason of my education, affiliation with a professional association (as defined in NI 43-101) and past relevant work experience, I fulfill the requirements to be a “Qualified Person” for the purposes of NI 43-101.

I have practiced my profession continuously since 2008. My summarized career experience is as follows:

- Associate Engineer, P&E Mining Consultants Aug 2017 - Present
- Mine Engineer, Lac des Iles Mine, North American Palladium May 2016 – Jun 2017
- Senior Underground Engineer, Phoenix Gold, Rubicon Minerals Sep 14 – Jan 2016
- Mine Engineer, Diavik Diamond Mine, Rio Tinto Diamonds Sep 2011 – Sep 2014
- Mine Engineer, Bengalla Mine, Rio Tinto Coal and Allied Dec 2008 – Sep 2011
- EIT, Creighton Mine, Vale-Inco May 2008 – Dec 2008

4. I have not visited the Property that is the subject of this Technical Report.
5. I am responsible for co-authoring Sections 1, 16, 21, 25, 26 and 27 of this Technical Report.
6. I am independent of the Issuer applying the test in Section 1.5 of NI 43-101. I am independent of the Vendor and the Property.
7. I have had no prior involvement with the Property that is the subject of this Technical Report.
8. I have read NI 43-101 and Form 43-101F1. This Technical Report has been prepared in compliance therewith.
9. As of the effective date of this Technical Report, to the best of my knowledge, information and belief, the Technical Report contains all scientific and technical information that is required to be disclosed to make the Technical Report not misleading.

Effective Date: February 15, 2023

Signing Date: March 31, 2023

{SIGNED AND SEALED}

[Greg Robinson]

Greg Robinson, P.Eng.

CERTIFICATE OF QUALIFIED PERSON

KIRK H. RODGERS, P. ENG

I, Kirk H. Rodgers, P. Eng., residing at 562 Mosley Street, Wasaga Beach, Ontario, do hereby certify that:

1. I am an independent mining consultant, contracted as Vice President, Engineering by P&E Mining Consultants Inc.
2. This certificate applies to the Technical Report titled “Preliminary Economic Assessment of the Fremont Gold Project, Mariposa County, Central California, USA”, (The “Technical Report”) with an effective date of February 15, 2023.
3. I am a graduate of The Haileybury School of Mines, with a Technologist Diploma in Mining. I subsequently attended the mining engineering programs at Laurentian University and Queen’s University for a total of two years. I have met the Professional Engineers of Ontario Academic Requirement Committee’s Examination requirement for Bachelor’s Degree in Engineering Equivalency. I have been licensed by the Professional Engineers of Ontario (License No. 39427505), from 1986 to the present. I am also a member of the National and Toronto Canadian Institute of Mining and Metallurgy.

I have read the definition of “Qualified Person” set out in National Instrument 43-101 (“NI 43-101”) and certify that by reason of my education, affiliation with a professional association (as defined in NI 43-101) and past relevant work experience, I fulfill the requirements to be a “Qualified Person” for the purposes of NI 43-101.

My relevant experience for the purpose of the Technical Report is:

- Underground Hard Rock Miner, Denison Mines, Elliot Lake Ontario 1977-1979
- Mine Planner, Cost Estimator, J.S Redpath Ltd., North Bay Ontario 1981-1987
- Chief Engineer, Placer Dome Dona Lake Mine, Pickle Lake Ontario 1987-1988
- Project Coordinator, Mine Captain, Falconbridge Kidd Creek Mine, Timmins, Ontario 1988-1990
- Manager of Contract Development, Dynatec Mining, Richmond Hill, Ontario 1990-1992
- General Manager, Moran Mining and Tunnelling, Sudbury, Ontario 1992-1993
- Independent Mining Engineer 1993
- Project Manager - Mining, Micon International, Toronto, Ontario 1994 - 2004
- Principal, Senior Consultant, Golder Associates, Toronto, Ontario 2004 – 2010
- Independent Consultant, VP Engineering to P&E Mining Consultants Inc, Brampton ON2011 – present

4. I have visited the Property that is the subject of this Technical Report on June 28, 2022.
5. I am responsible for co-authoring Sections 1, 16, 25, 26 and 27 of this Technical Report.
6. I am independent of the issuer applying the test in Section 1.5 of NI 43-101.
7. I have had no prior involvement with the Project that is the subject of this Technical Report.
8. I have read NI 43-101 and Form 43-101F1 and the Technical Report has been prepared in compliance therewith.
9. As of the effective date of this Technical Report, to the best of my knowledge, information and belief, the Technical Report contains all scientific and technical information that is required to be disclosed to make the Technical Report not misleading.

Effective Date: February 15, 2023

Signing Date: March 31, 2023

{SIGNED AND SEALED}

[Kirk Rodgers]

Kirk Rodgers, P.Eng.

CERTIFICATE OF QUALIFIED PERSON

WILLIAM STONE, PH.D., P.GEO.

I, William Stone, Ph.D., P.Geo, residing at 4361 Latimer Crescent, Burlington, Ontario, do hereby certify that:

1. I am an independent geological consultant working for P&E Mining Consultants Inc.
2. This certificate applies to the Technical Report titled “Preliminary Economic Assessment of the Fremont Gold Project, Mariposa County, Central California, USA”, (The “Technical Report”) with an effective date of February 15, 2023.
3. I am a graduate of Dalhousie University with a Bachelor of Science (Honours) degree in Geology (1983). In addition, I have a Master of Science in Geology (1985) and a Ph.D. in Geology (1988) from the University of Western Ontario. I have worked as a geologist for a total of 35 years since obtaining my M.Sc. degree. I am a geological consultant currently licensed by the Professional Geoscientists of Ontario (License No 1569).

I have read the definition of “Qualified Person” set out in National Instrument 43-101 (“NI 43-101”) and certify that, by reason of my education, affiliation with a professional association (as defined in NI 43-101) and past relevant work experience, I fulfill the requirements to be a “Qualified Person” for the purposes of NI 43-101.

My relevant experience for the purpose of the Technical Report is:

- Contract Senior Geologist, LAC Minerals Exploration Ltd. 1985-1988
- Post-Doctoral Fellow, McMaster University 1988-1992
- Contract Senior Geologist, Outokumpu Mines and Metals Ltd. 1993-1996
- Senior Research Geologist, WMC Resources Ltd. 1996-2001
- Senior Lecturer, University of Western Australia 2001-2003
- Principal Geologist, Geoinformatics Exploration Ltd. 2003-2004
- Vice President Exploration, Nevada Star Resources Inc. 2005-2006
- Vice President Exploration, Goldbrook Ventures Inc. 2006-2008
- Vice President Exploration, North American Palladium Ltd. 2008-2009
- Vice President Exploration, Magma Metals Ltd. 2010-2011
- President & COO, Pacific North West Capital Corp. 2011-2014
- Consulting Geologist 2013-2017
- Senior Project Geologist, Anglo American 2017-2019
- Consulting Geoscientist 2020-Present

4. I have not visited the Property that is the subject of this Technical Report.
5. I am responsible for authoring Sections 4 to 10, and 23, and co-authoring Sections 1, 21, 25, 26 and 27 of this Technical Report.
6. I am independent of the Issuer applying the test in Section 1.5 of NI 43-101.
7. I have had prior involvement with the Project that is the subject of this Technical Report. I was a “Qualified Person” for a Technical Report titled “Technical Report and Updated Mineral Resource Estimate of the Pine Tree-Josephine and Queen Specimen Deposits, Fremont Gold Project, Mariposa County, Central California, USA”, with an effective date of June 30, 2022.
8. I have read NI 43-101 and Form 43-101F1 and this Technical Report has been prepared in compliance therewith.
9. As of the effective date of this Technical Report, to the best of my knowledge, information and belief, the Technical Report contains all scientific and technical information that is required to be disclosed to make the Technical Report not misleading.

Effective Date: February 15, 2023

Signing Date: March 31, 2023

{SIGNED AND SEALED}

[William Stone]

William E. Stone, Ph.D., P.Geo.

CERTIFICATE OF QUALIFIED PERSON

TRAVIS MANNING, P.E.

I, Travis Manning, P.E., residing in Reno, Nevada, do hereby certify that:

1. I am a Senior Engineer for Kappes, Cassiday & Associates located at 7950 Security Circle, Reno, Nevada 89506.
2. This certificate applies to the Technical Report titled “Preliminary Economic Assessment of the Fremont Gold Project, Mariposa County, Central California, USA”, (The “Technical Report”) with an effective date of February 15, 2023.
3. I am a graduate of the University of Nevada with a Bachelor of Science degree in Metallurgical Engineering (2002). I have worked as a metallurgical engineer for 19 years since graduating. I am a metallurgical engineer currently licensed by the State of Utah (No. 6880159-2202). I am a Registered Member of the Society for Mining, Metallurgy and Exploration (4138289RM).

I have read the definition of “qualified person” set out in National Instrument 43-101 (“NI 43-101”) and certify that, by reason of my education, affiliation with a professional association (as defined in NI 43-101) and past relevant work experience, I fulfill the requirements to be a “qualified person” for the purposes of NI 43-101.

My relevant experience for the purpose of the Technical Report is:

- Metallurgical Engineer, Kappes, Cassiday & Associates 2002-2010
- Chief Metallurgist, Coeur Alaska 2010-2012
- Senior Engineer/Project Manager, Kappes, Cassiday & Associates 2013-Present

4. I have visited the Property that is the subject of this Technical Report on June 28, 2022.
5. I am responsible for authoring Section 13, 17 and 18, and co-authoring Sections 1, 21, 25, 26 and 27 of this Technical Report.
6. I am independent of the Issuer applying the test in Section 1.5 of NI 43-101.
7. I have had prior involvement with the Project that is the subject of this Technical Report. I was a “Qualified Person” for a Technical Report titled “Technical Report and Updated Mineral Resource Estimate of the Pine Tree-Josephine and Queen Specimen Deposits, Fremont Gold Project, Mariposa County, Central California, USA”, with an effective date of June 30, 2022.
8. I have read NI 43-101 and Form 43-101F1 and this Technical Report has been prepared in compliance therewith.
9. As of the effective date of this Technical Report, to the best of my knowledge, information and belief, the Technical Report contains all scientific and technical information that is required to be disclosed to make the Technical Report not misleading.

Effective Date: February 15, 2023

Signed Date: March 31, 2023

{SIGNED AND SEALED}

[Travis Manning]

Travis Manning, P.E.

APPENDIX A SURFACE DRILL HOLE PLAN

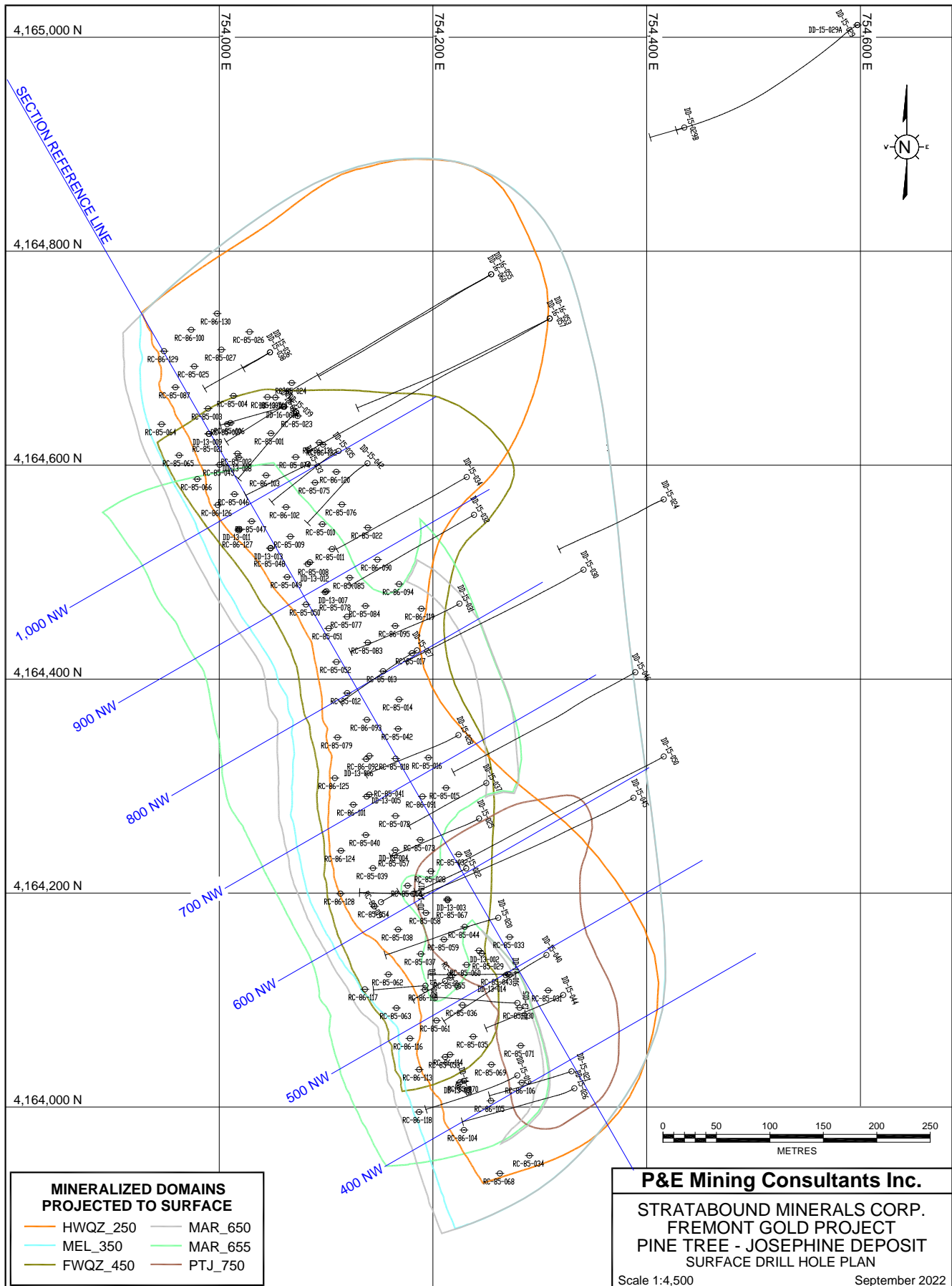

MINERALIZED DOMAINS PROJECTED TO SURFACE	
— HWQZ_250	— MAR_650
— MEL_350	— MAR_655
— FWQZ_450	— PTJ_750

P&E Mining Consultants Inc.
 STRATABOUND MINERALS CORP.
 FREMONT GOLD PROJECT
 PINE TREE - JOSEPHINE DEPOSIT
 SURFACE DRILL HOLE PLAN
 Scale 1:4,500 September 2022

APPENDIX B 3-D DOMAINS

FREMONT GOLD PROJECT PINE TREE - JOSEPHINE DEPOSIT 3D DOMAINS

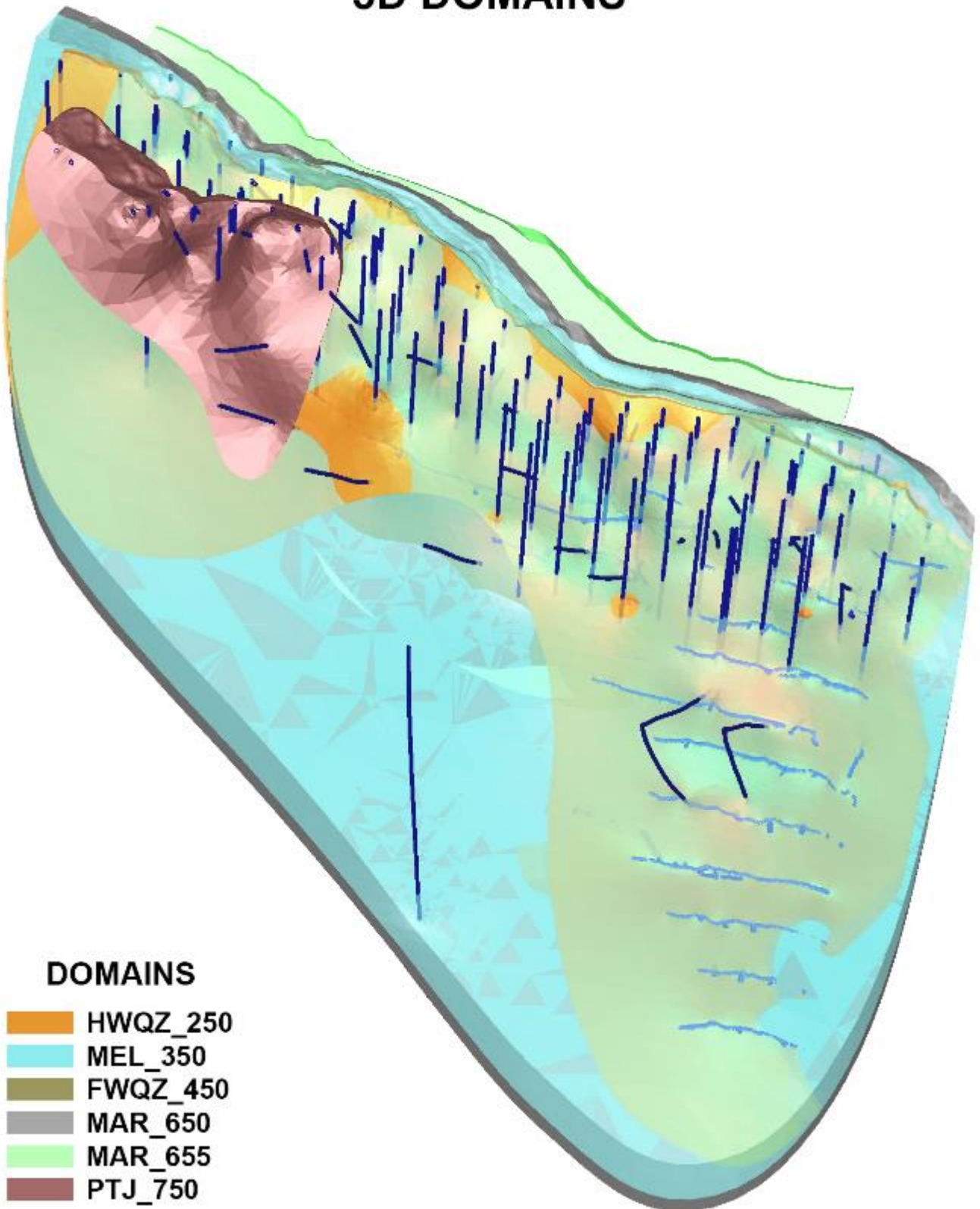

FREMONT GOLD PROJECT QUEEN SPECIMEN DEPOSIT 3D DOMAINS



APPENDIX C LOG PROBABILITY PLOTS

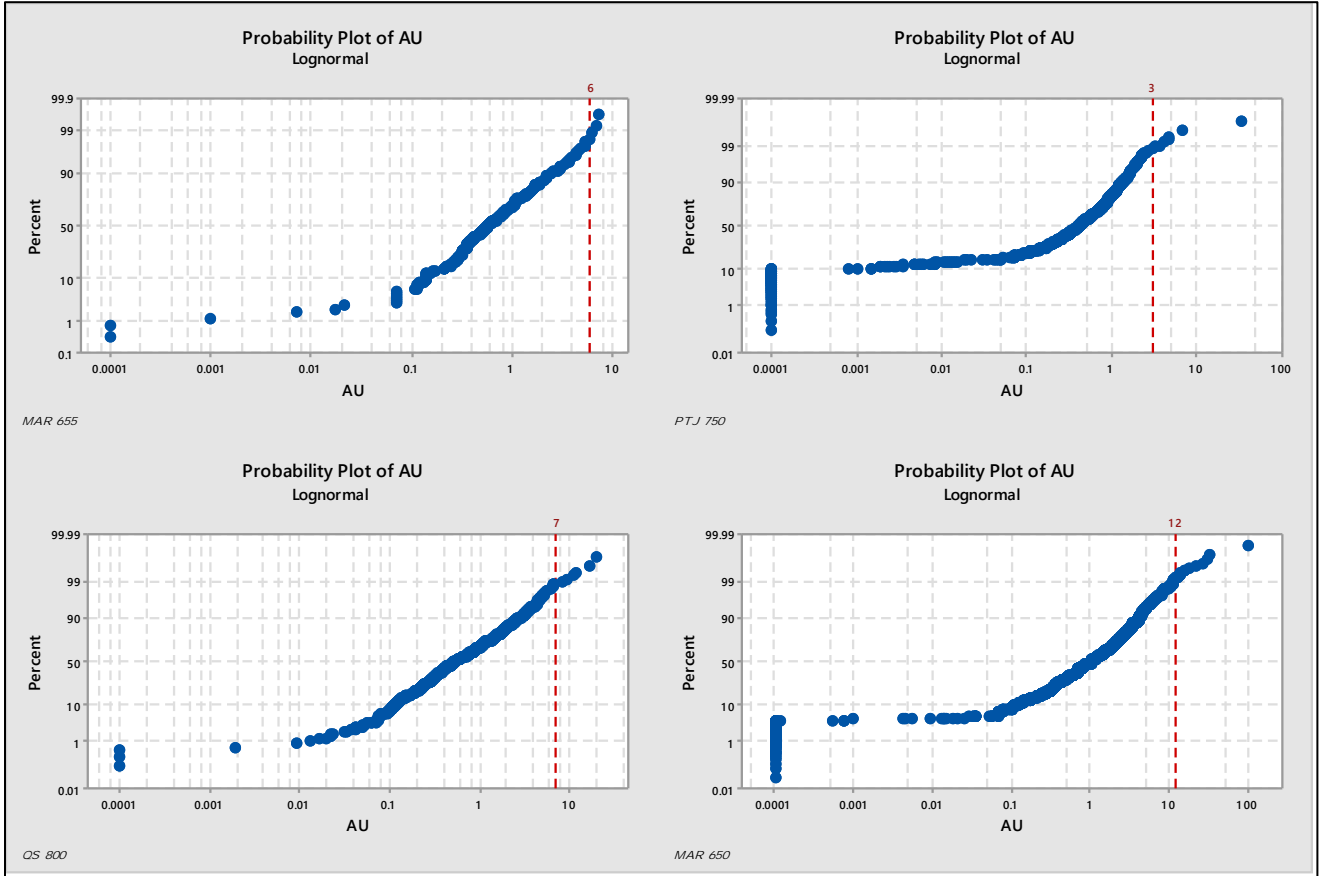
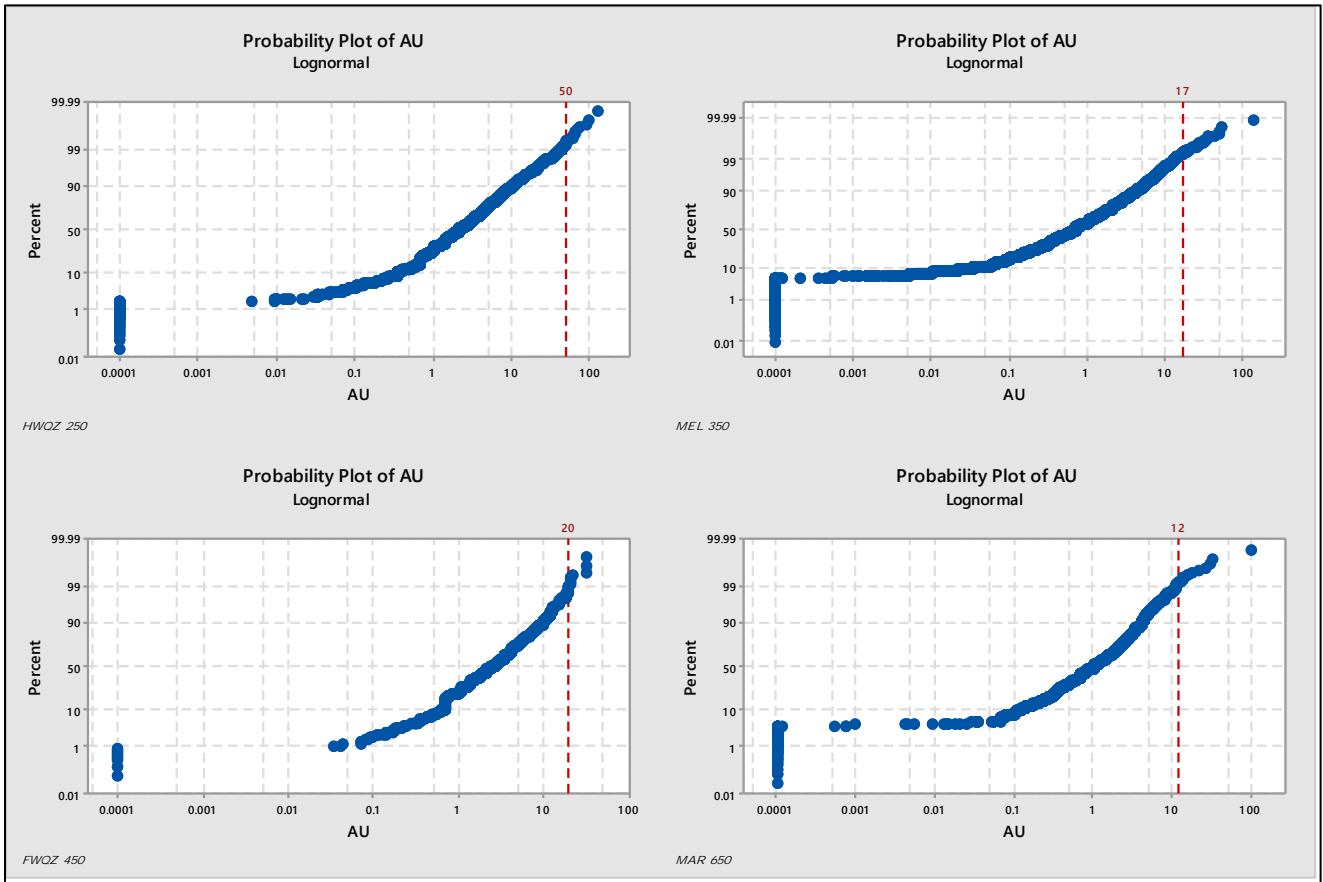

APPENDIX D VARIOGRAMS

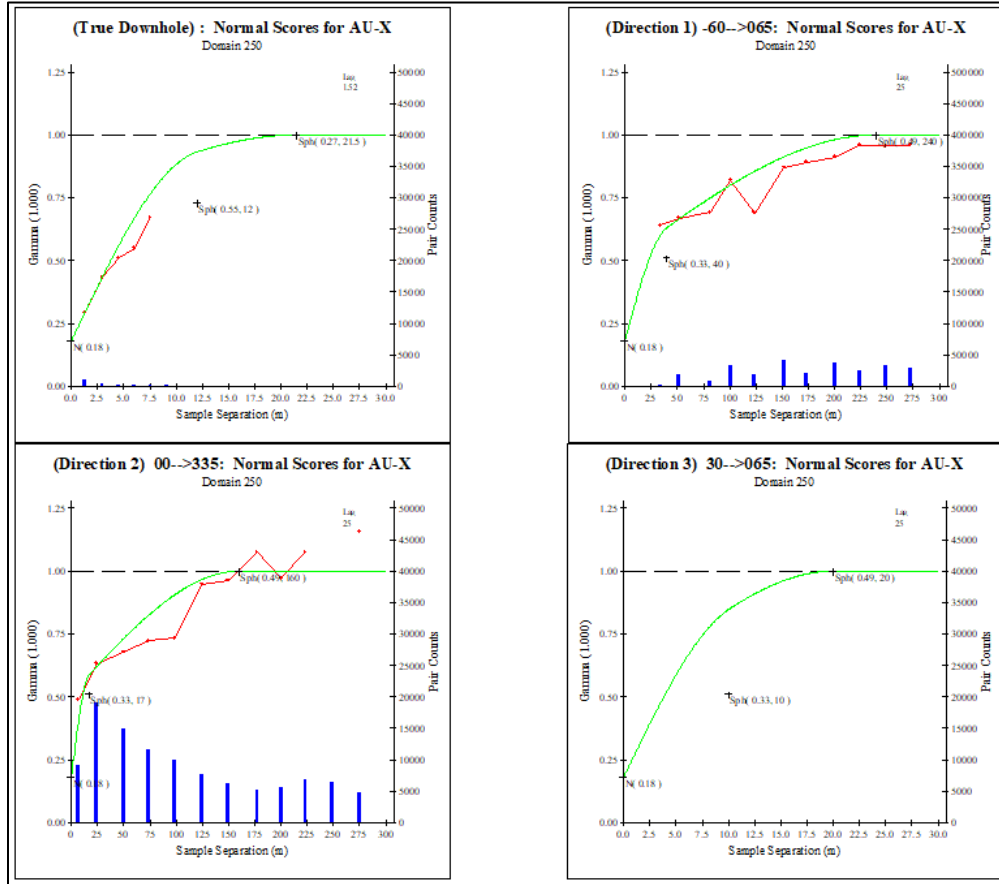

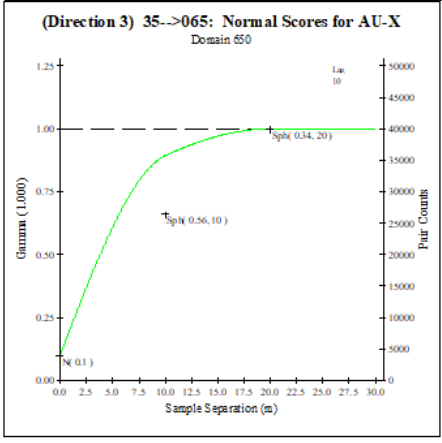
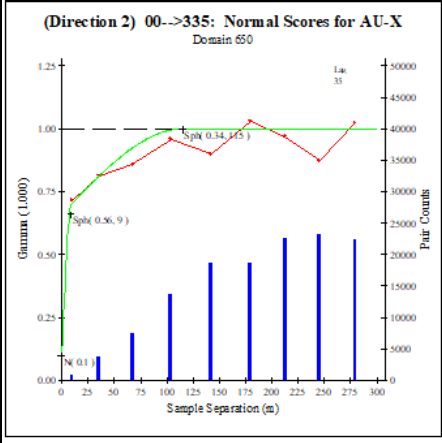
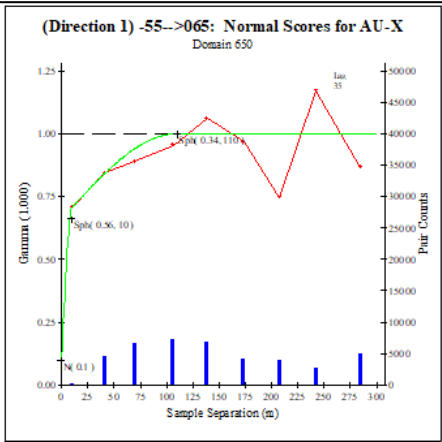
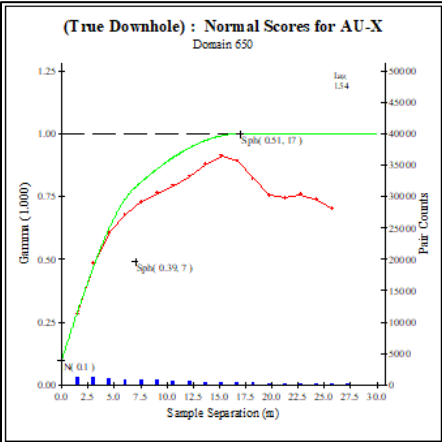
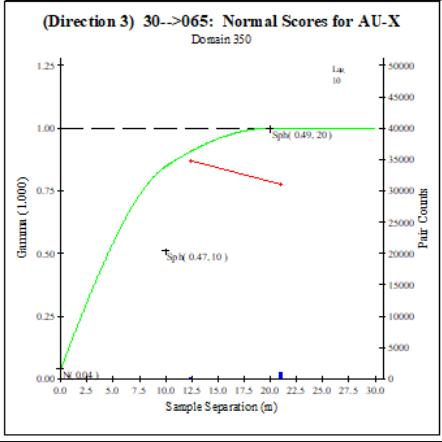
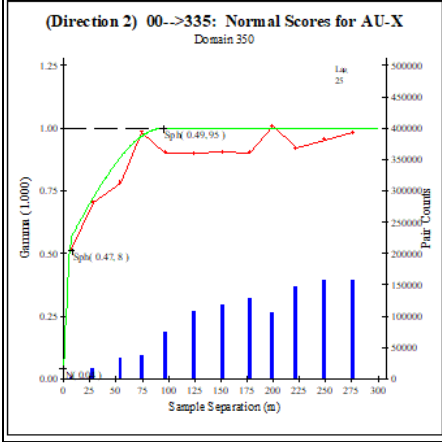
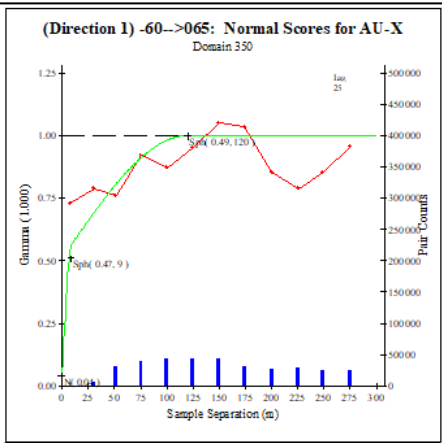
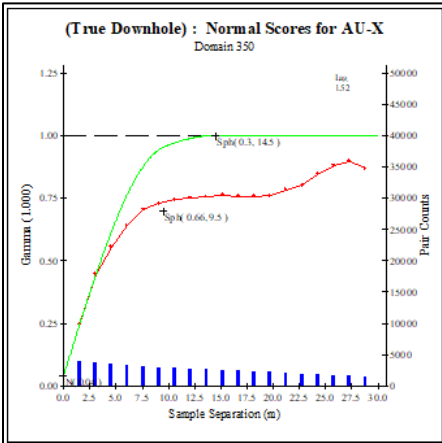

APPENDIX E BLOCK MODEL CROSS SECTIONS AND PLANS

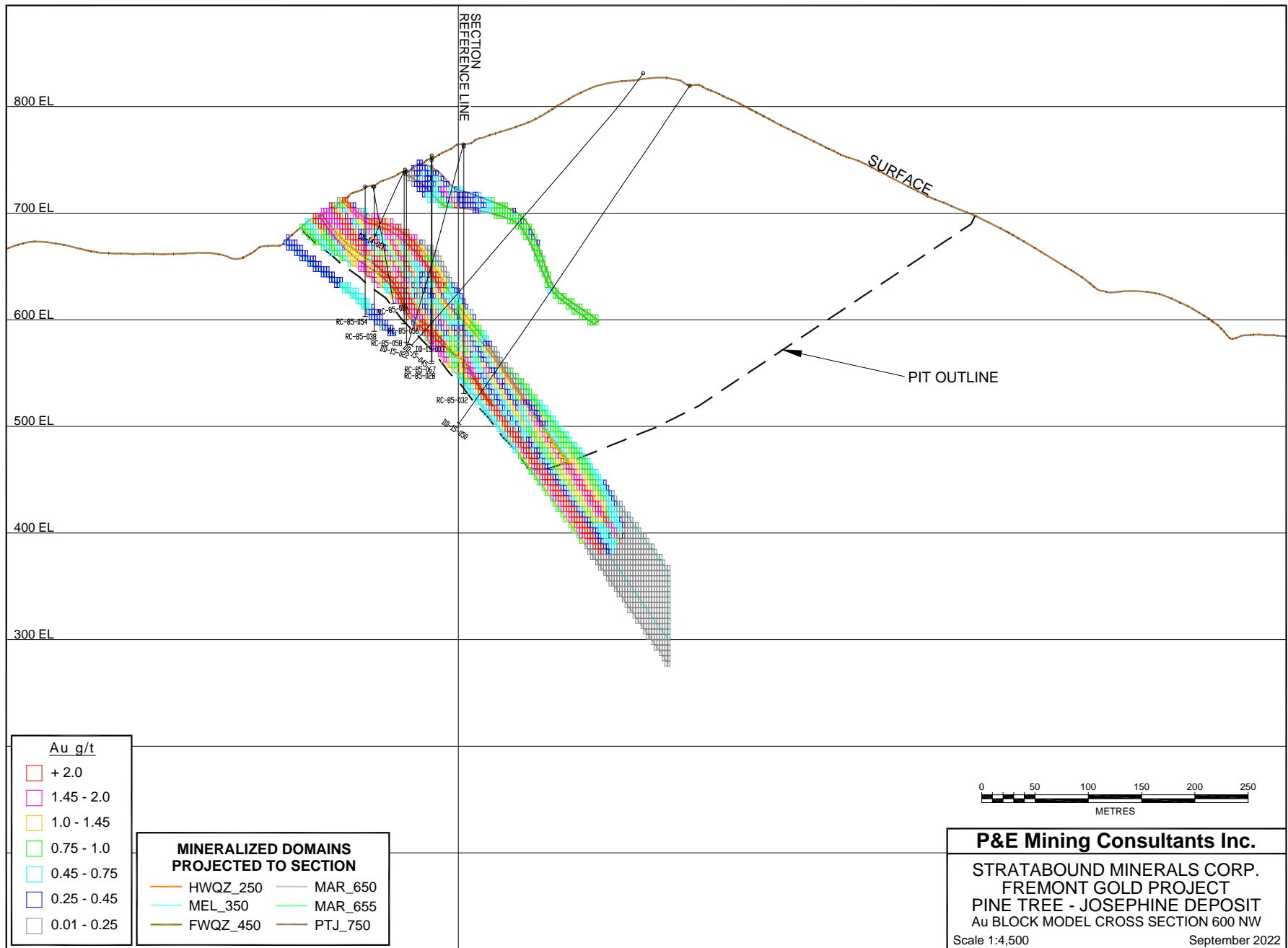

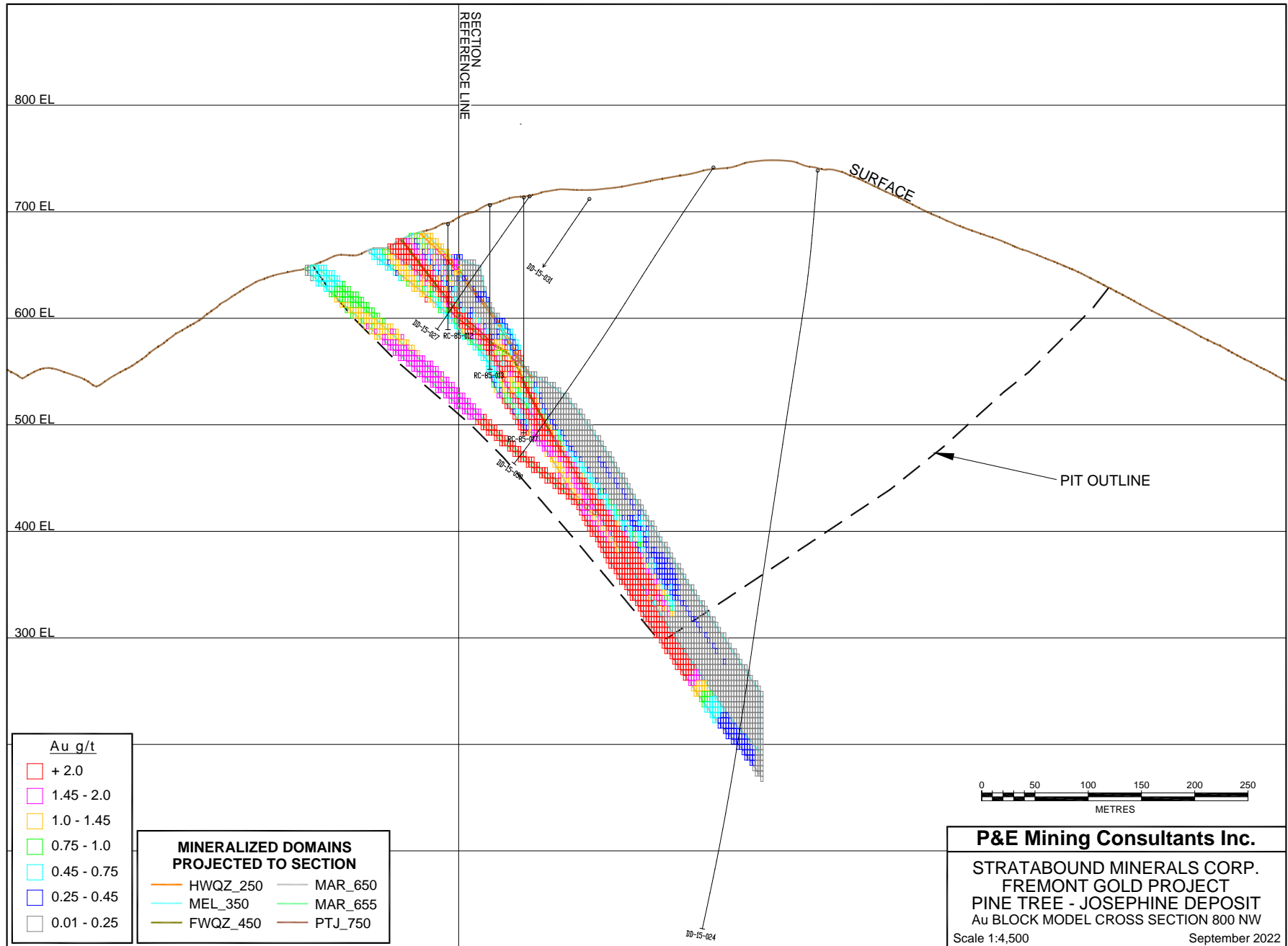

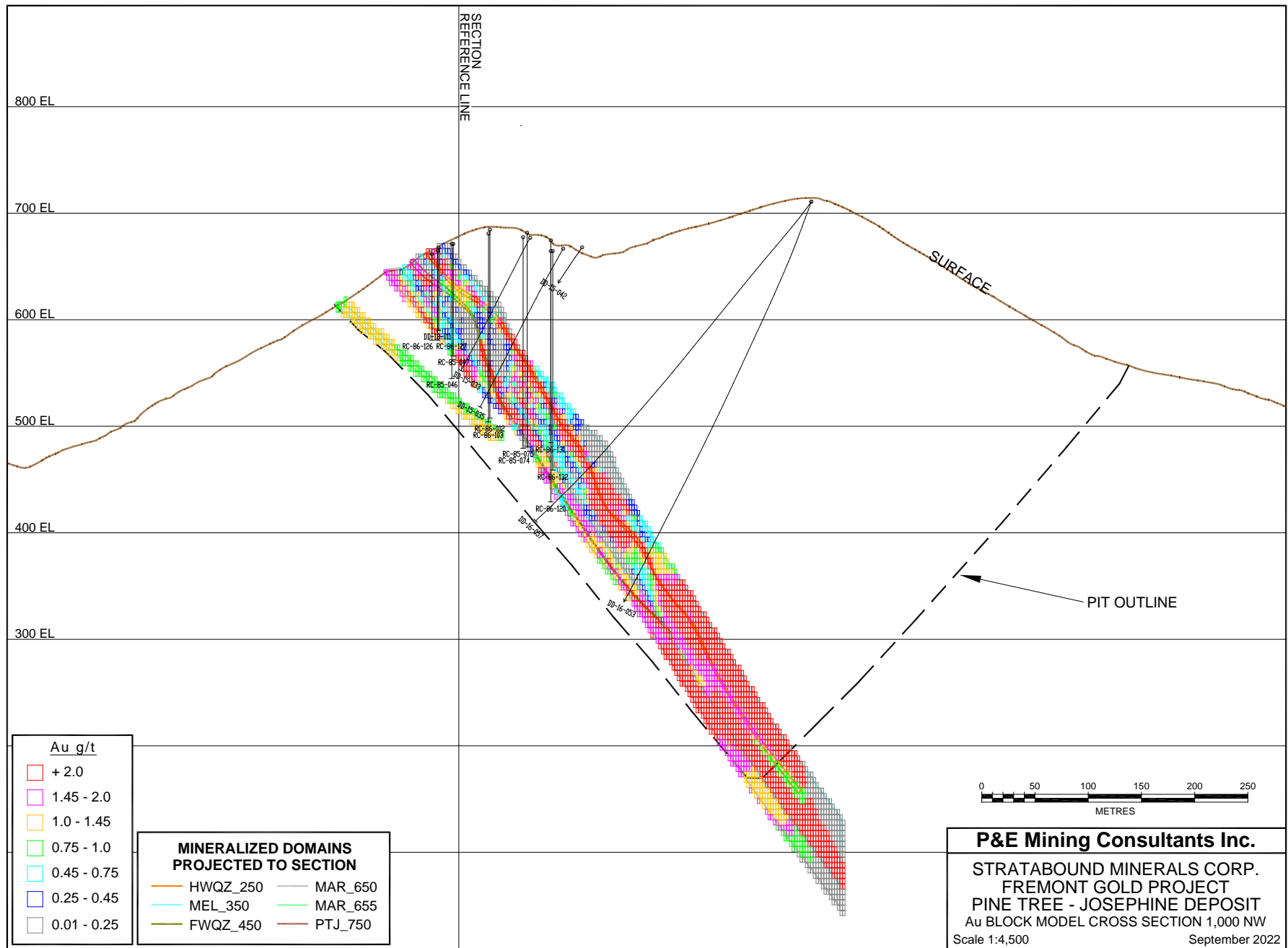

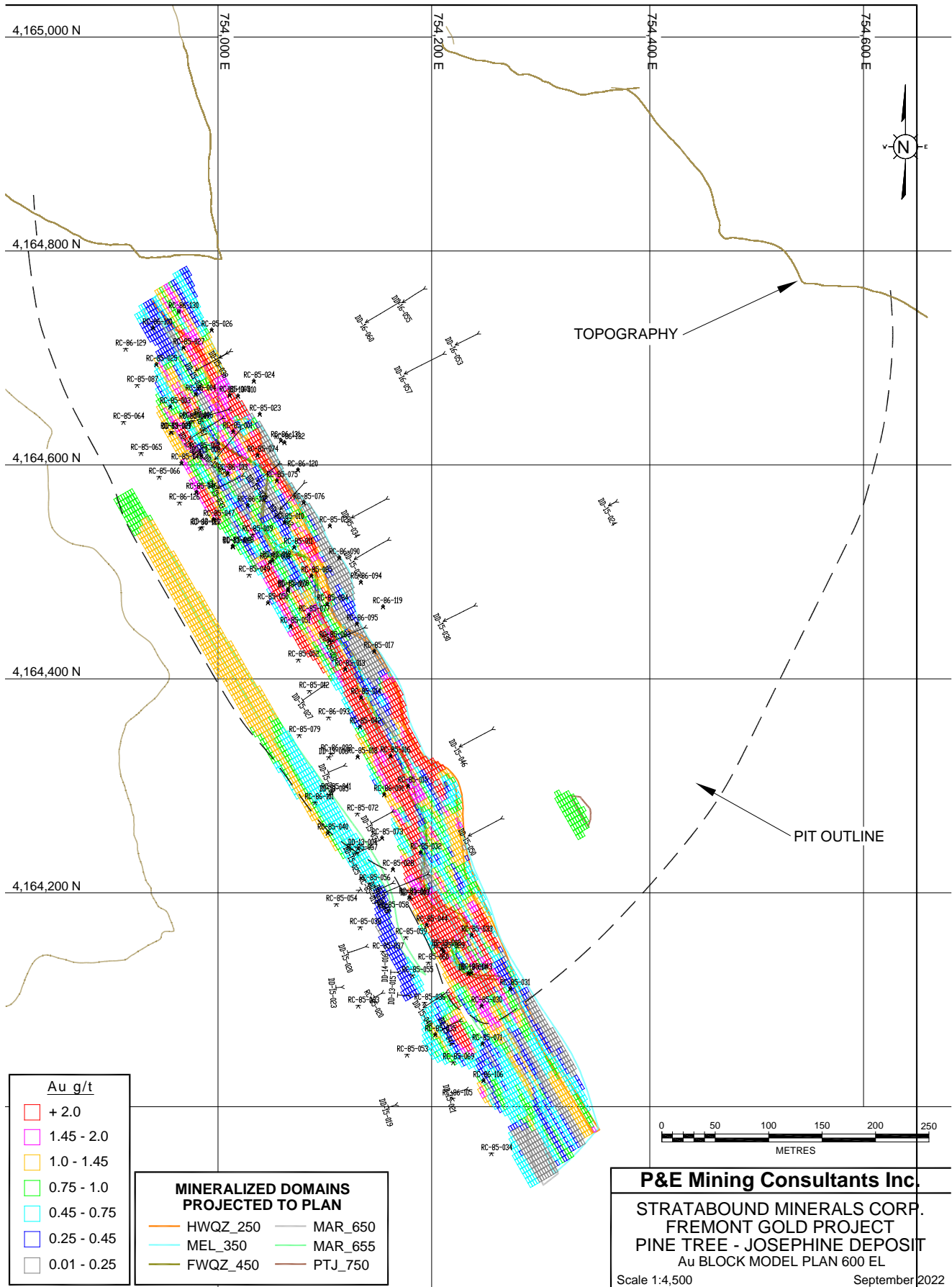

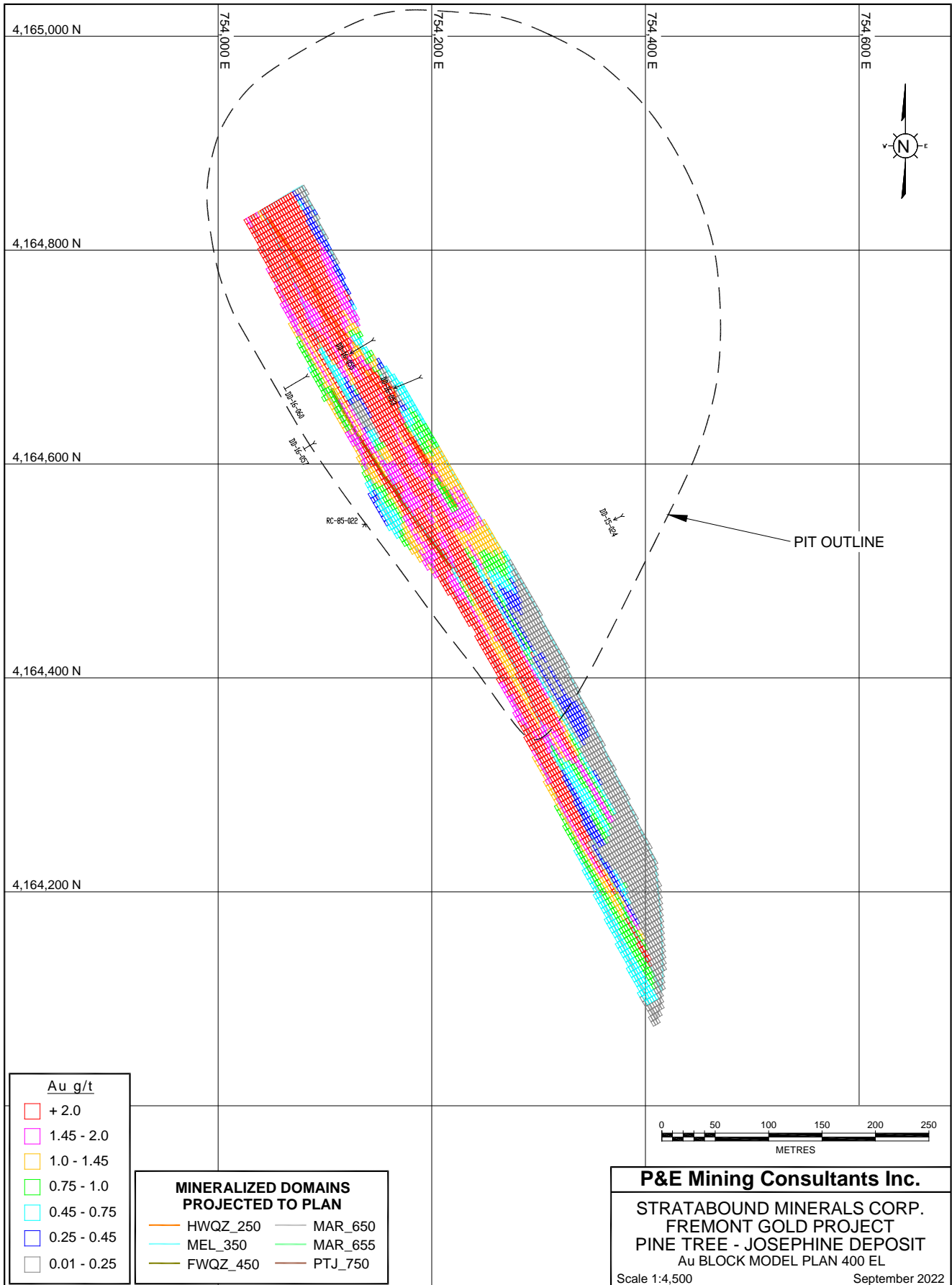

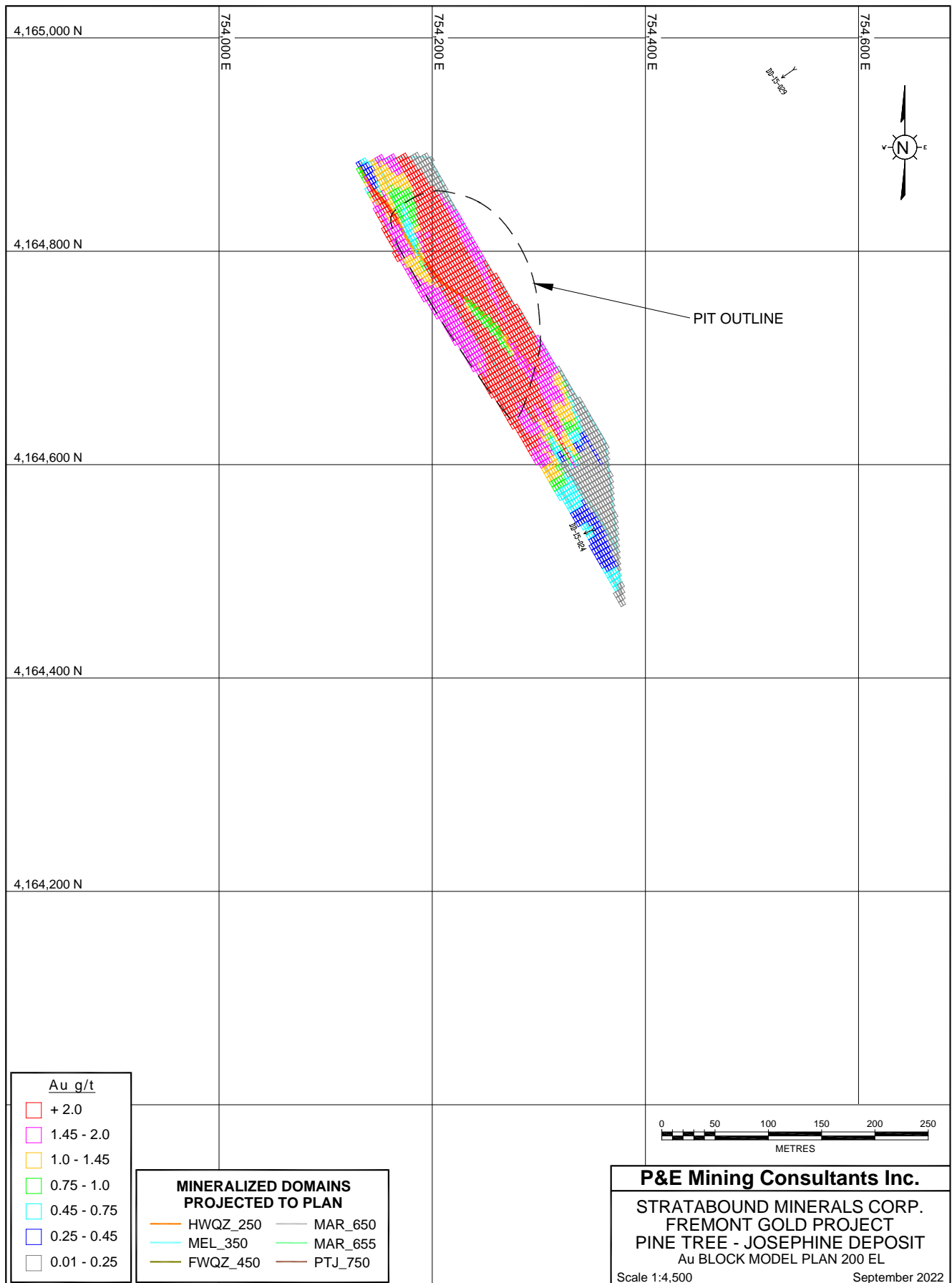

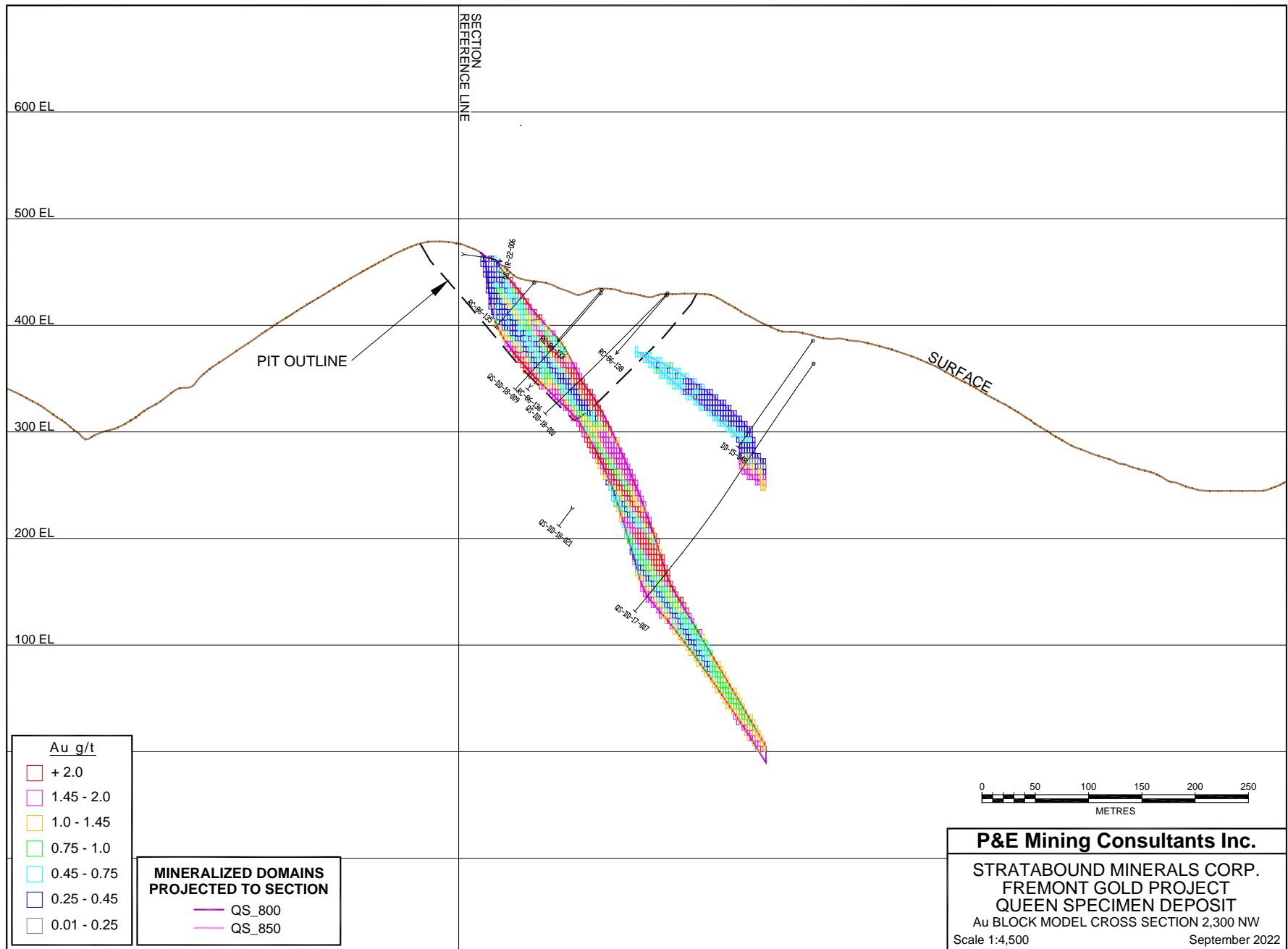

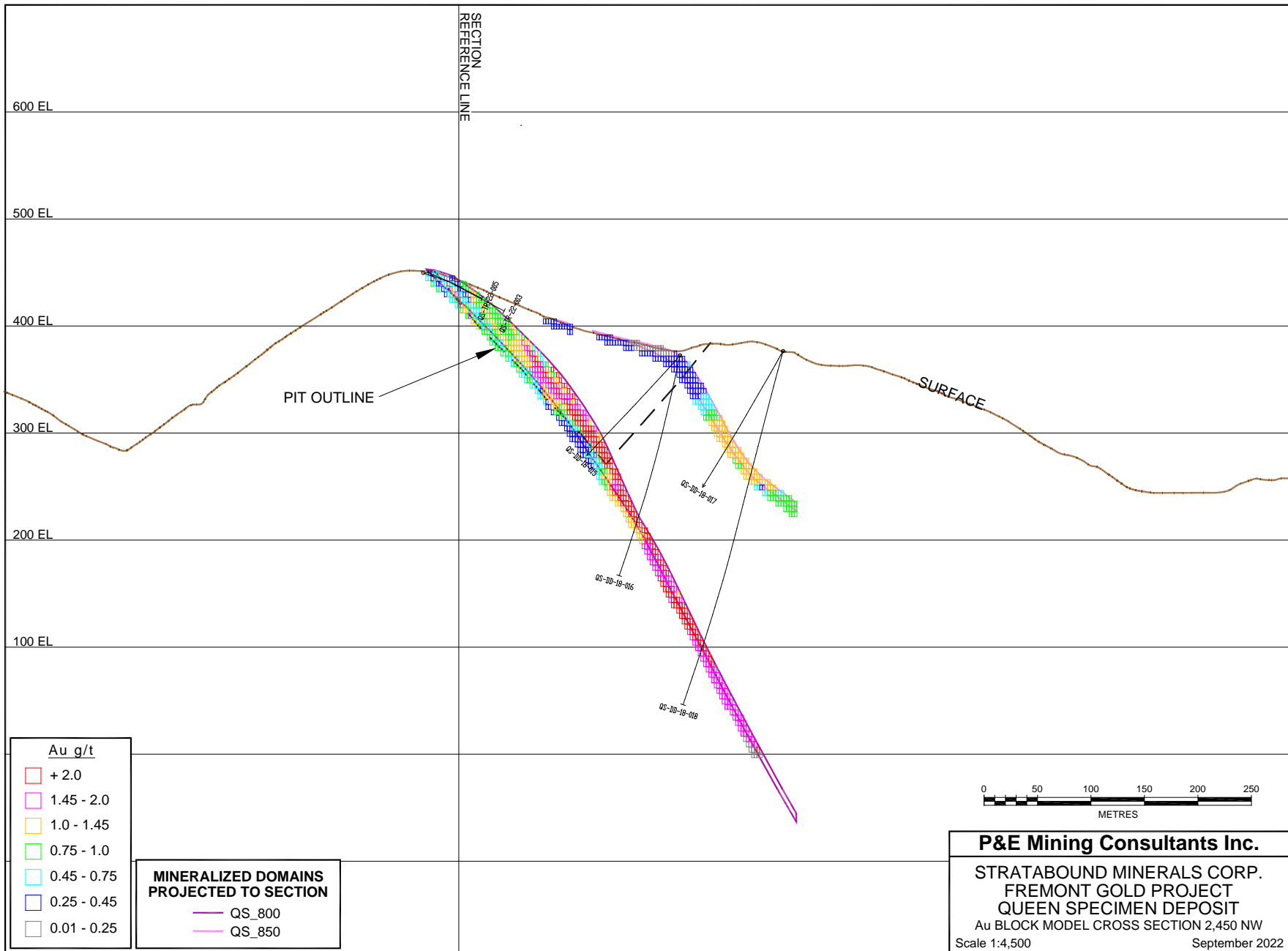

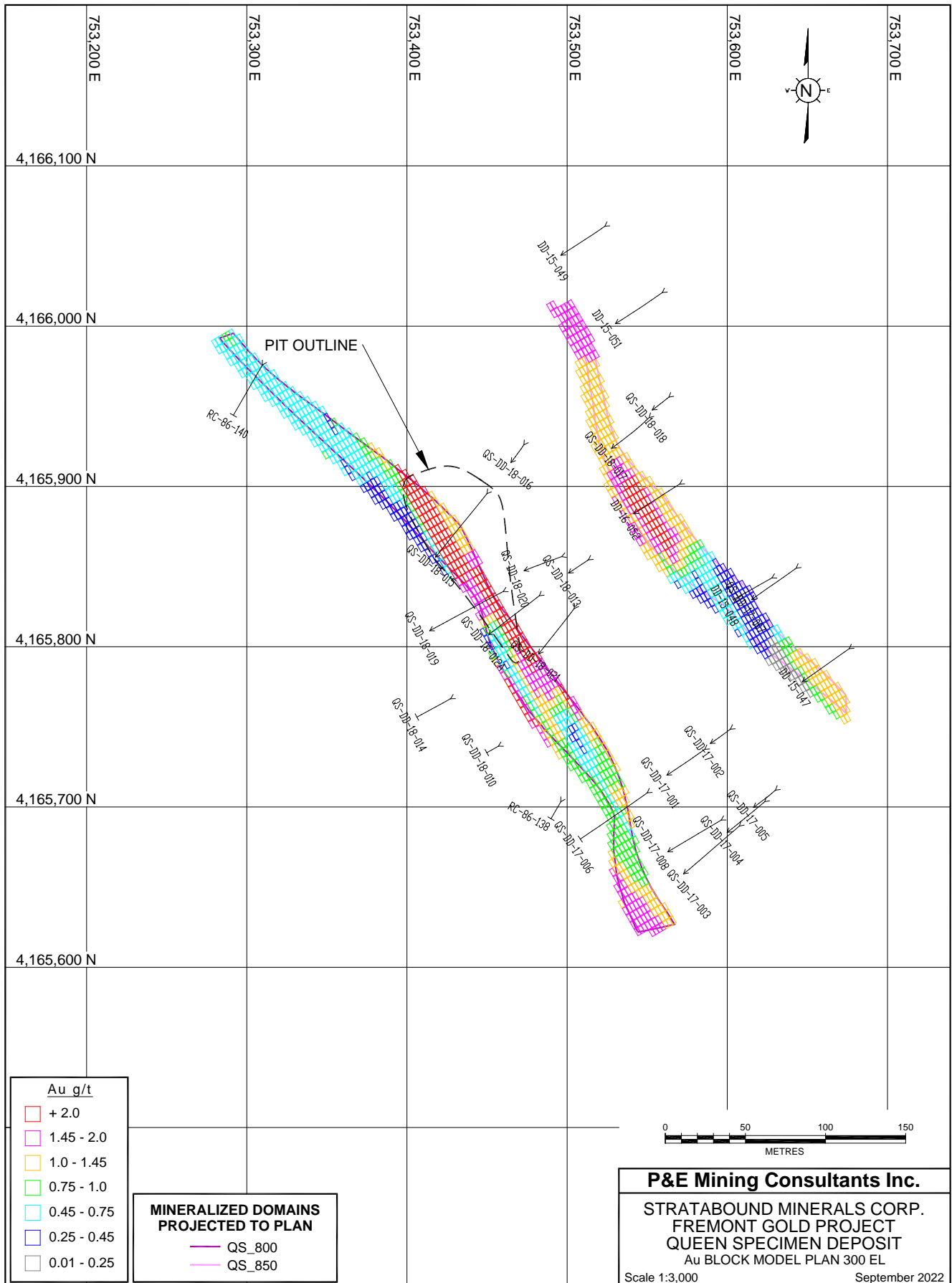

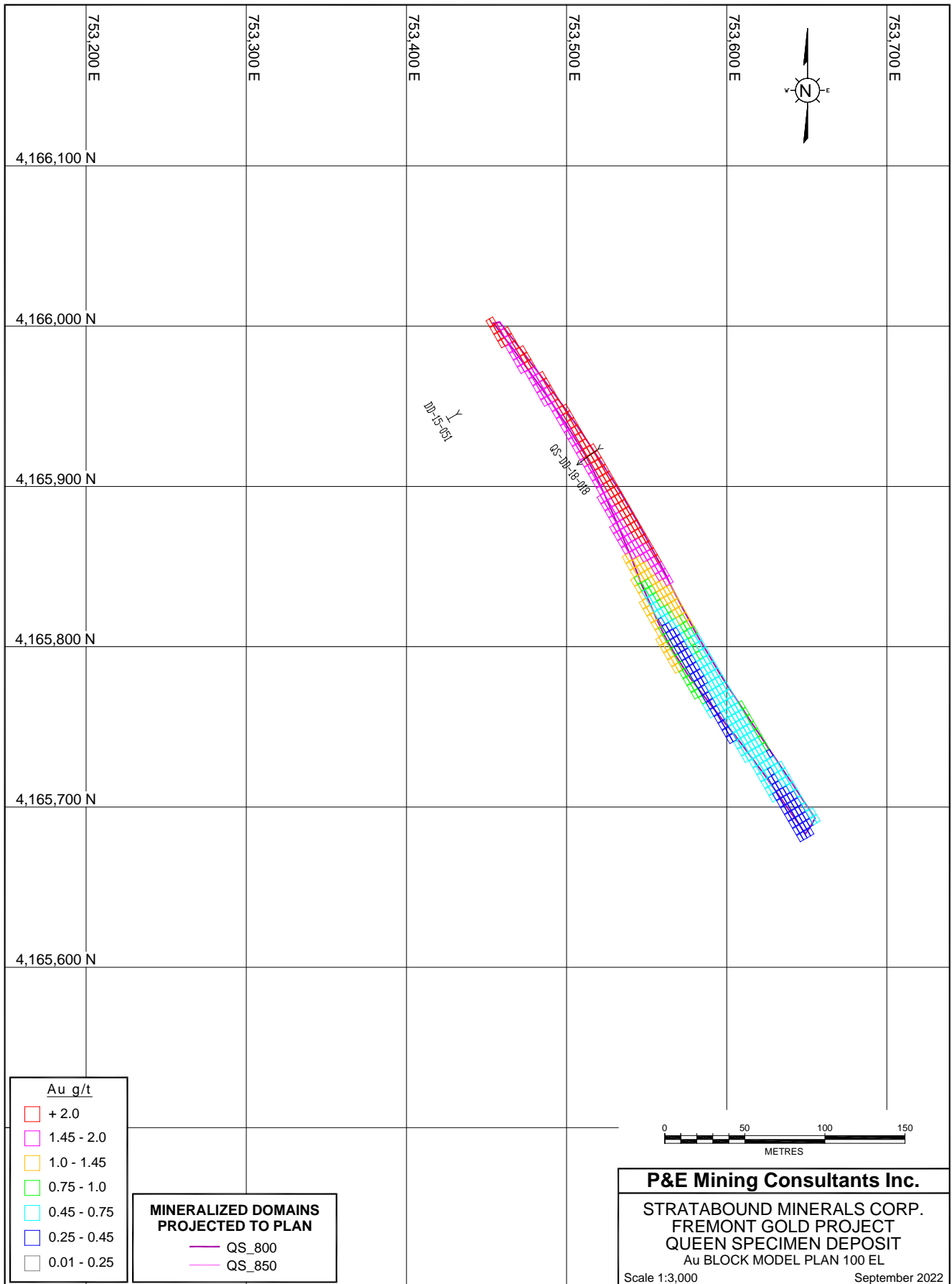

APPENDIX F CLASSIFICATION BLOCK MODEL CROSS SECTIONS AND PLANS

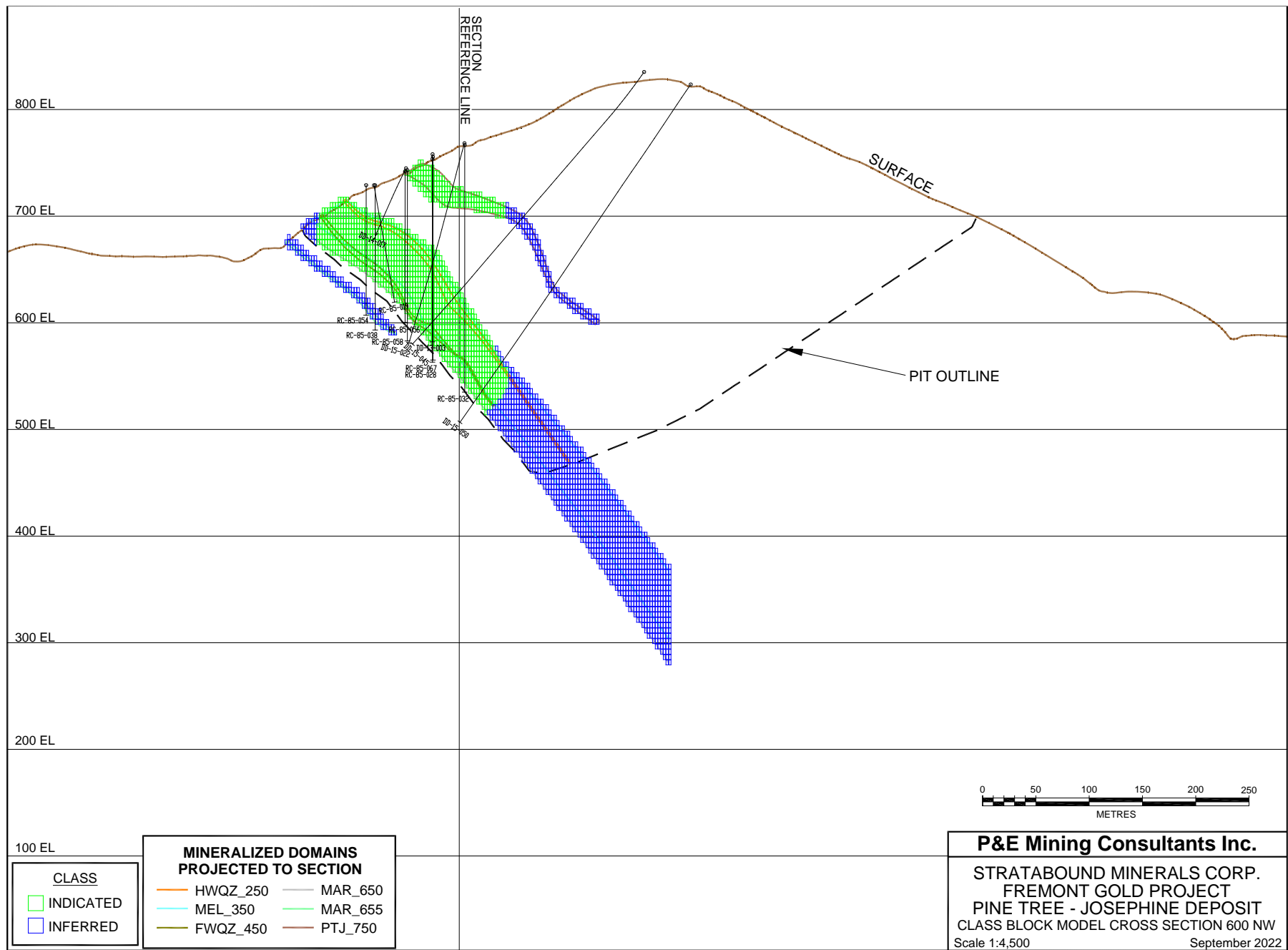

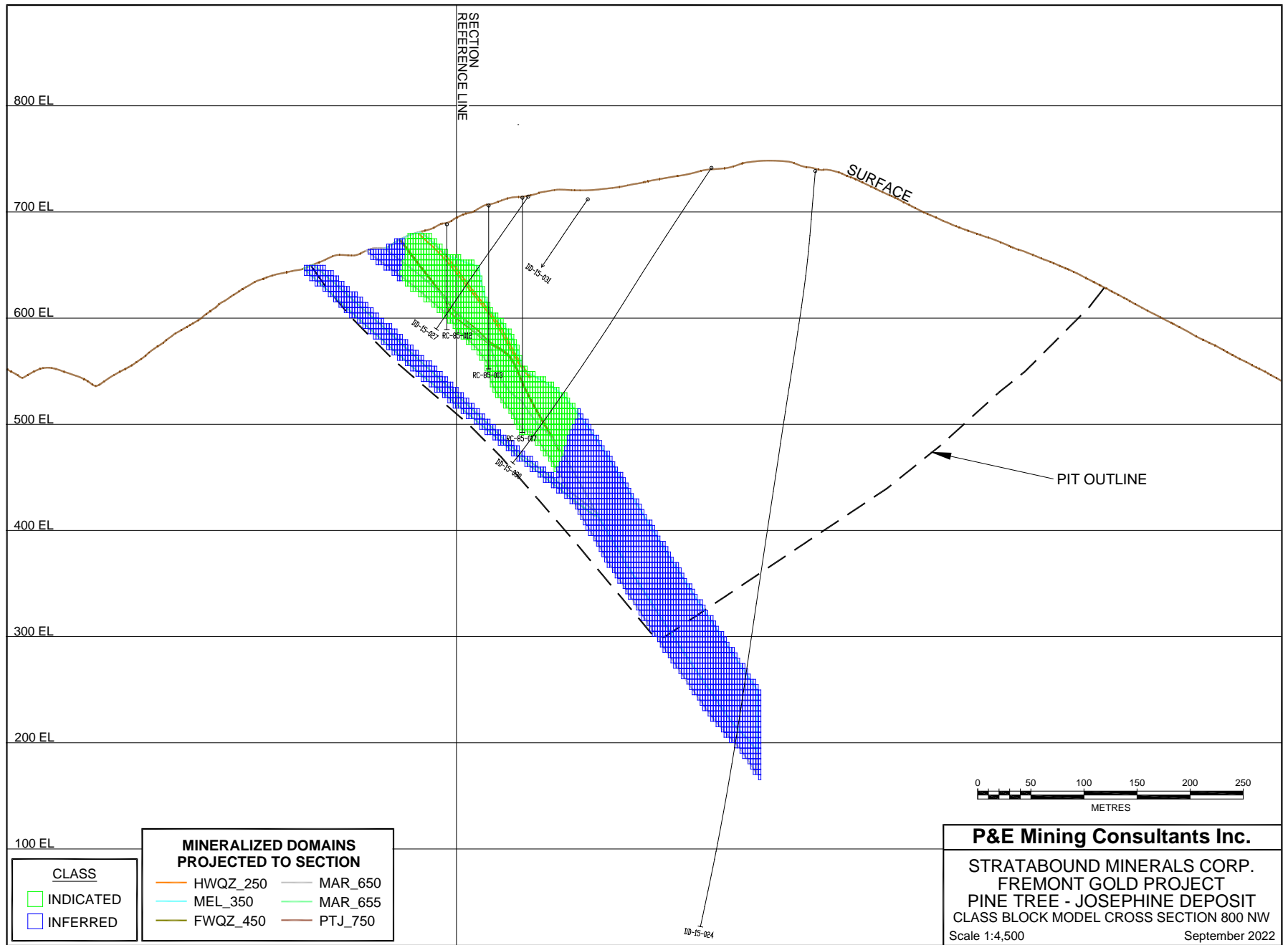

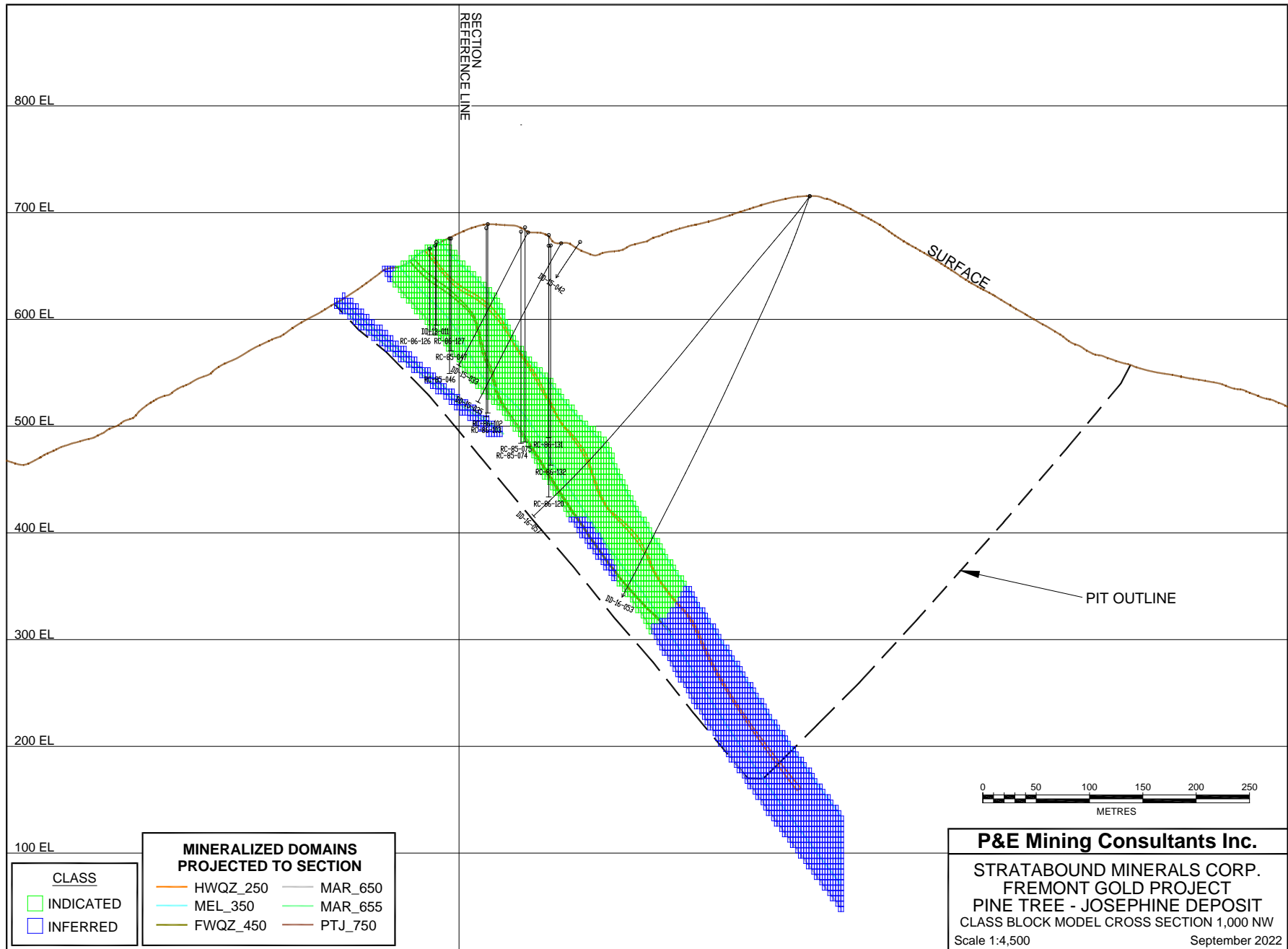

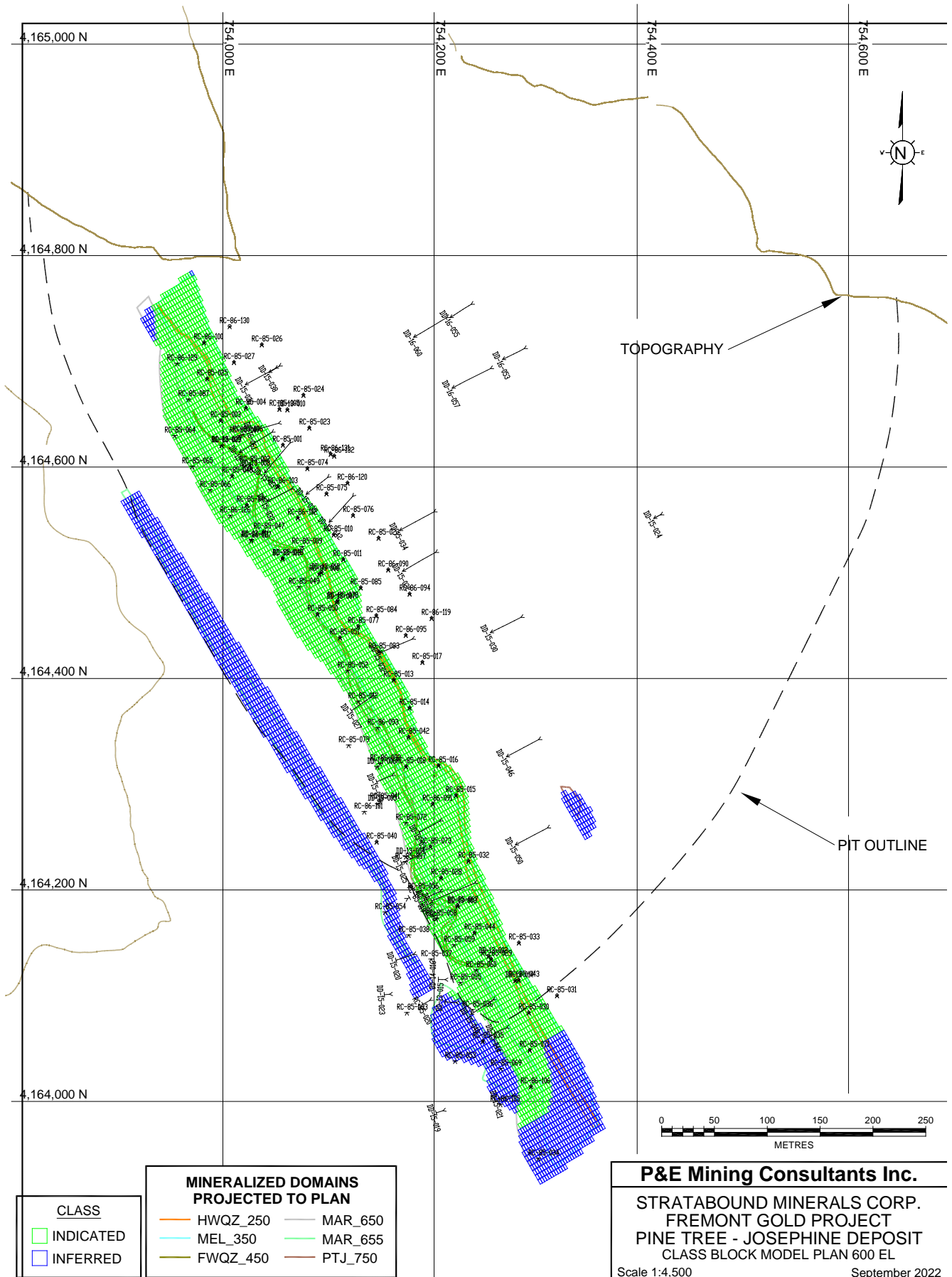

CLASS	
■	INDICATED
■	INFERRED

MINERALIZED DOMAINS PROJECTED TO PLAN			
—	HWQZ_250	—	MAR_650
—	MEL_350	—	MAR_655
—	FWQZ_450	—	PTJ_750

P&E Mining Consultants Inc.
STRATABOUND MINERALS CORP.
FREMONT GOLD PROJECT
PINE TREE - JOSEPHINE DEPOSIT
CLASS BLOCK MODEL PLAN 600 EL
 Scale 1:4,500 September 2022

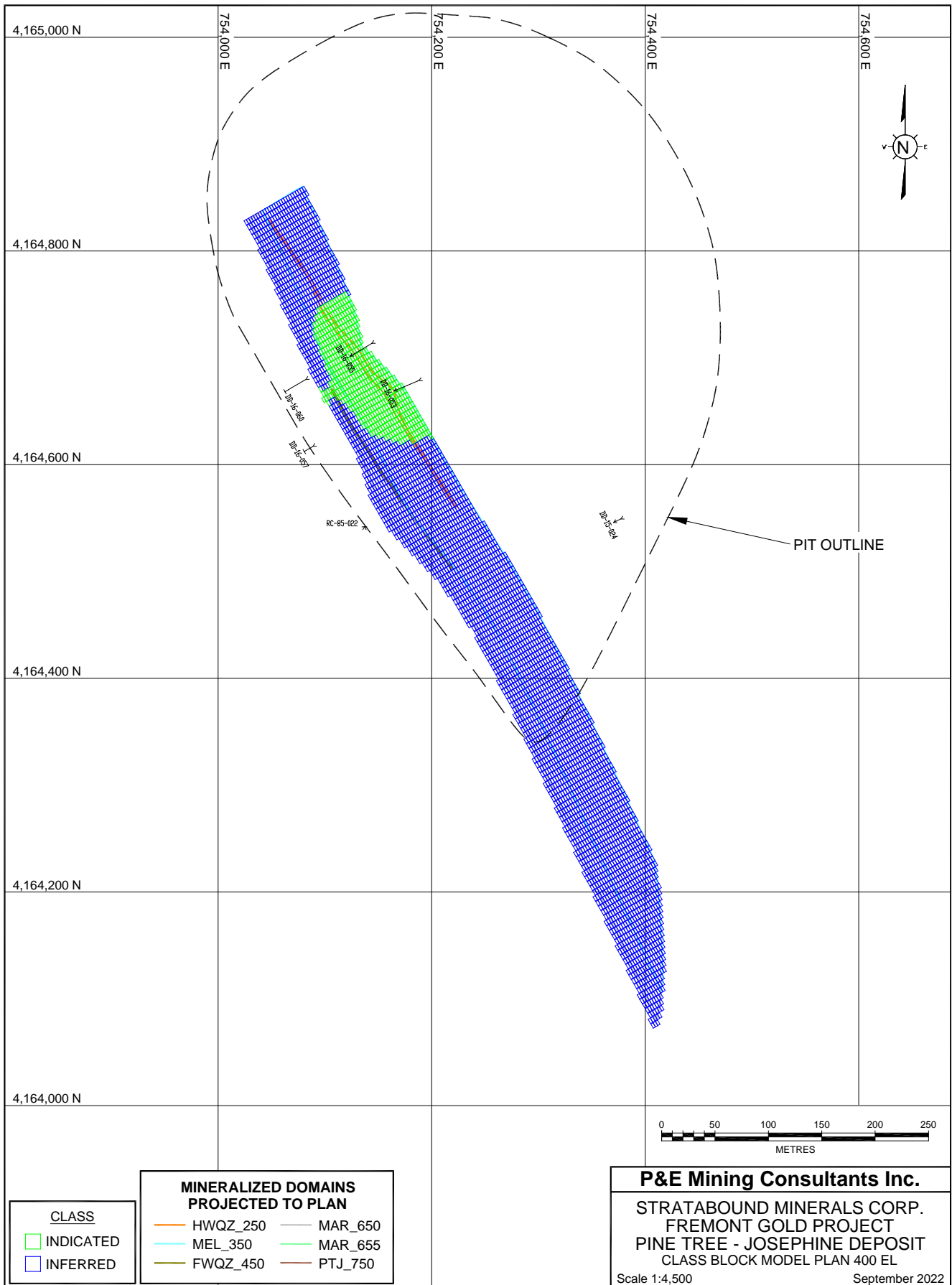

CLASS	
	INDICATED
	INFERRED

MINERALIZED DOMAINS PROJECTED TO PLAN			
	HWQZ_250		MAR_650
	MEL_350		MAR_655
	FWQZ_450		PTJ_750

P&E Mining Consultants Inc.

STRATABOUND MINERALS CORP.
 FREMONT GOLD PROJECT
 PINE TREE - JOSEPHINE DEPOSIT
 CLASS BLOCK MODEL PLAN 400 EL

Scale 1:4,500 September 2022

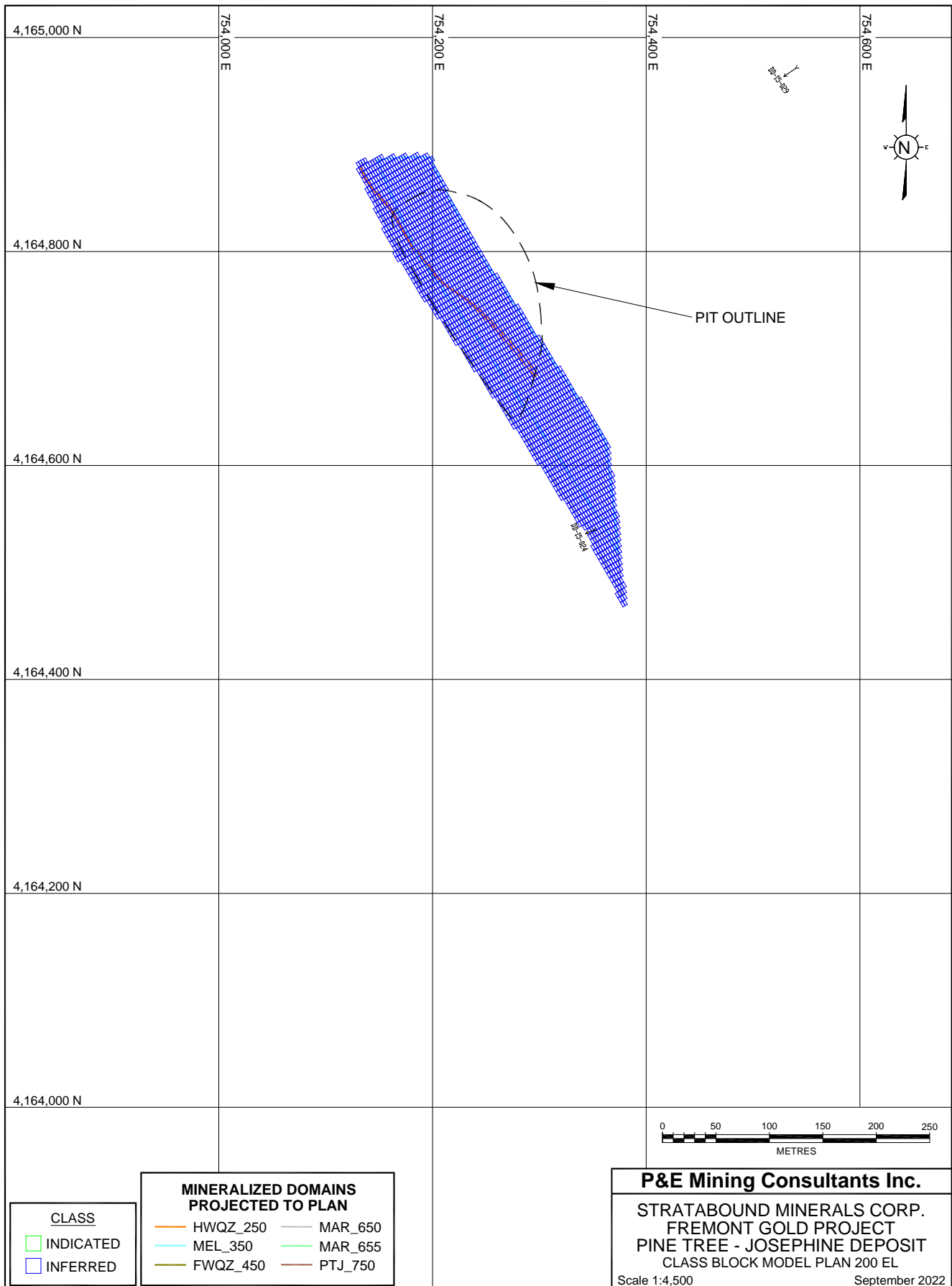

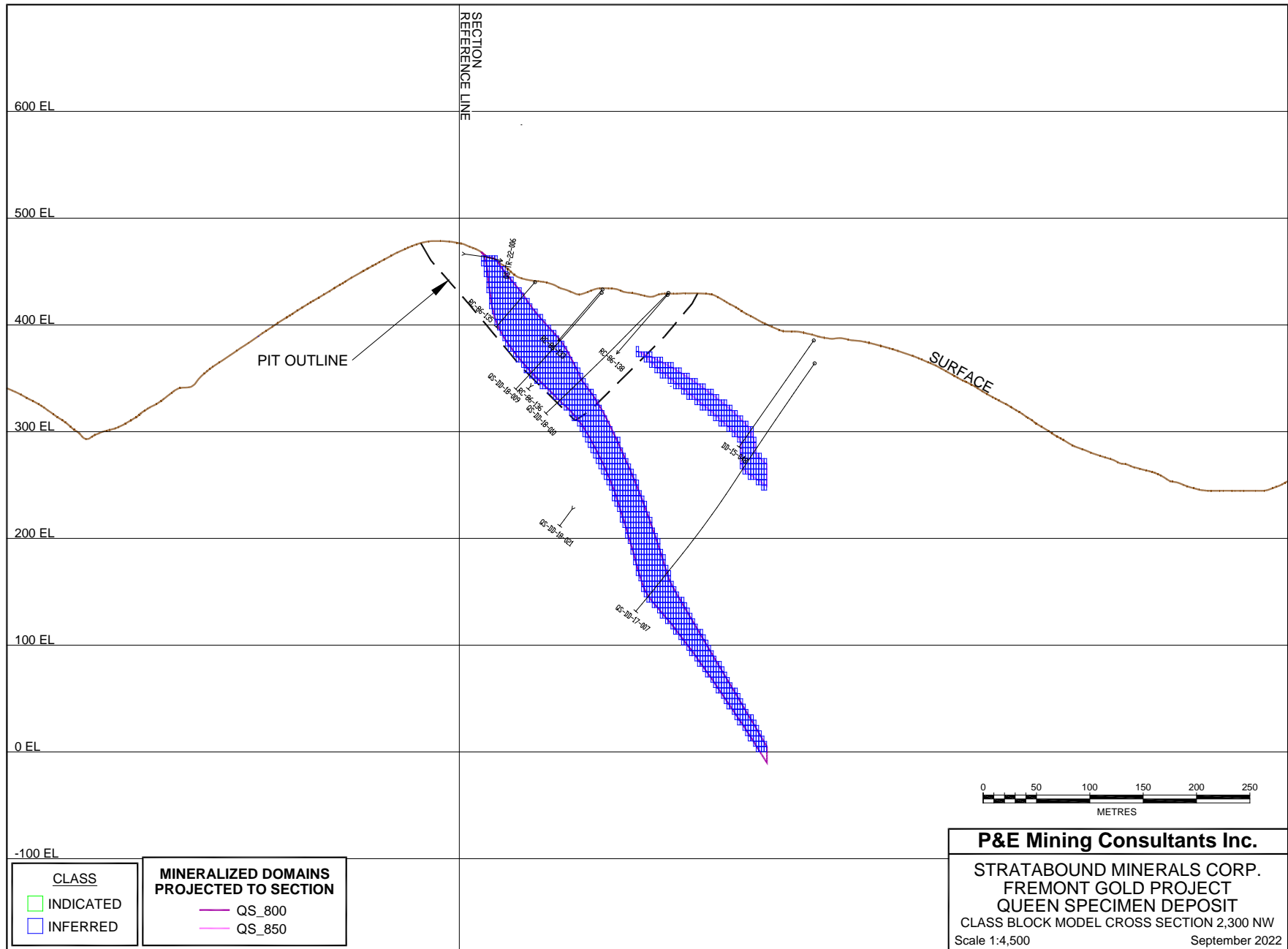

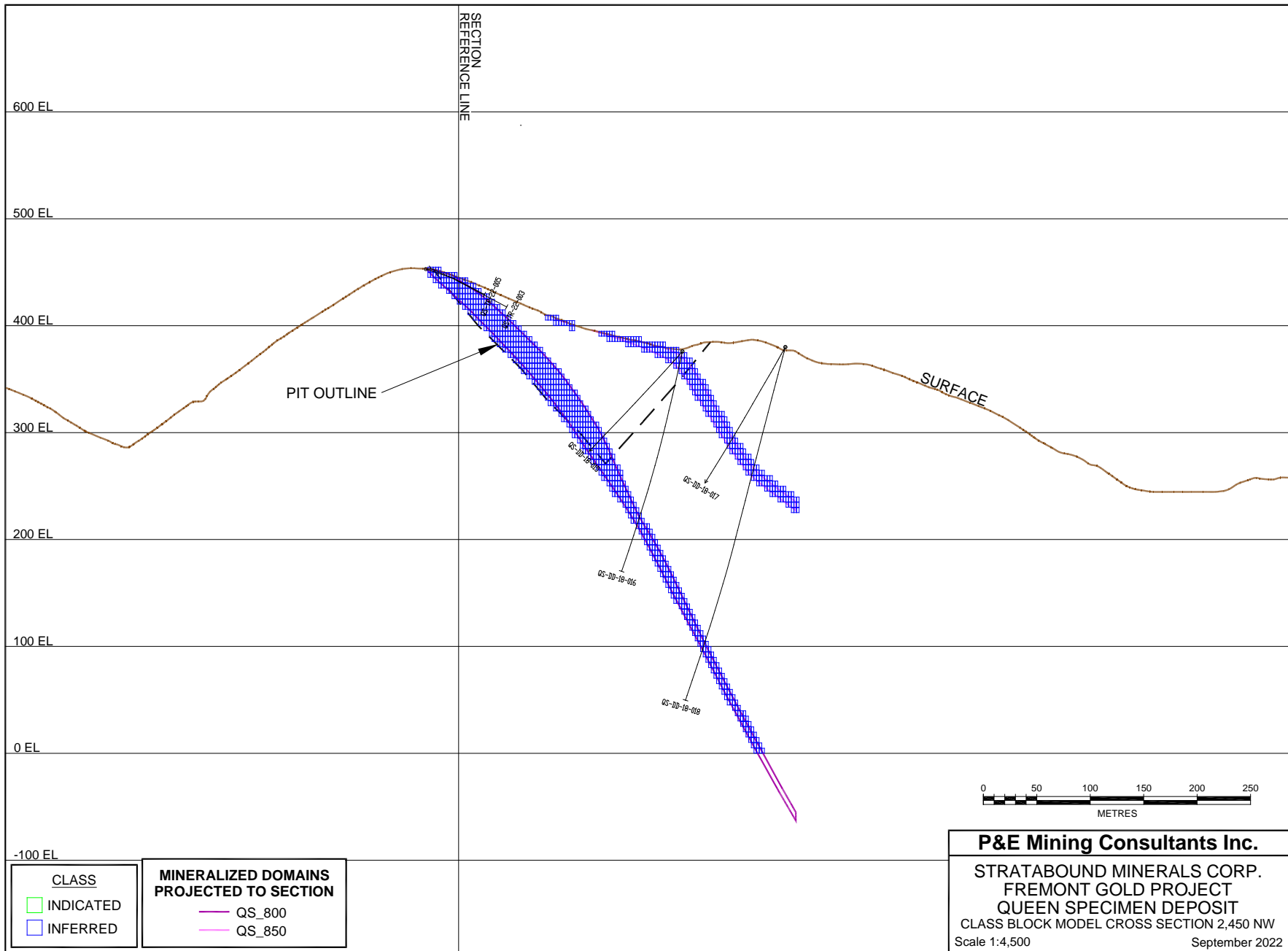

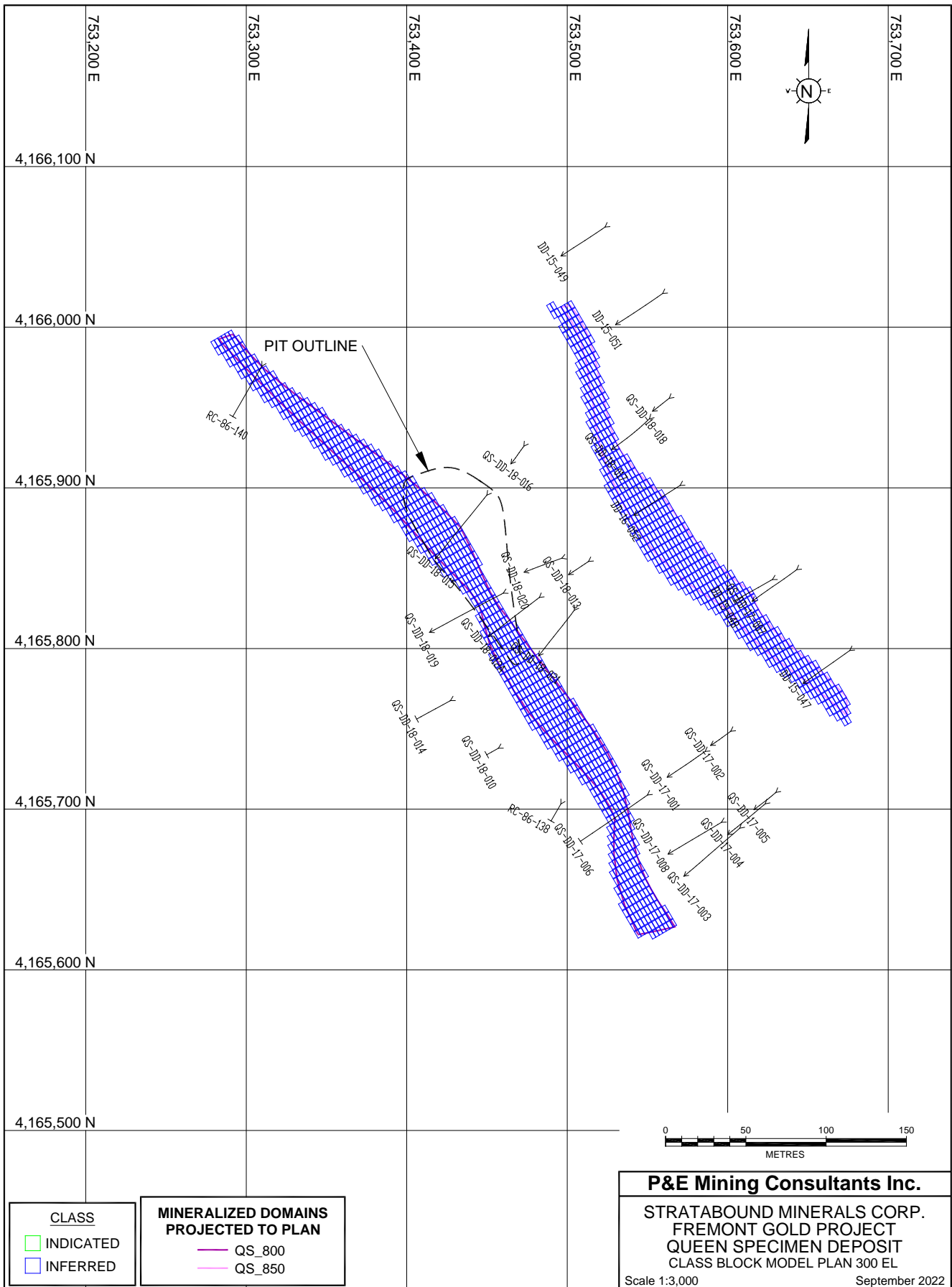

CLASS	
■	INDICATED
■	INFERRED

MINERALIZED DOMAINS PROJECTED TO PLAN	
—	QS_800
—	QS_850

P&E Mining Consultants Inc.

STRATABOUND MINERALS CORP.
FREMONT GOLD PROJECT
QUEEN SPECIMEN DEPOSIT
CLASS BLOCK MODEL PLAN 300 EL

Scale 1:3,000 September 2022

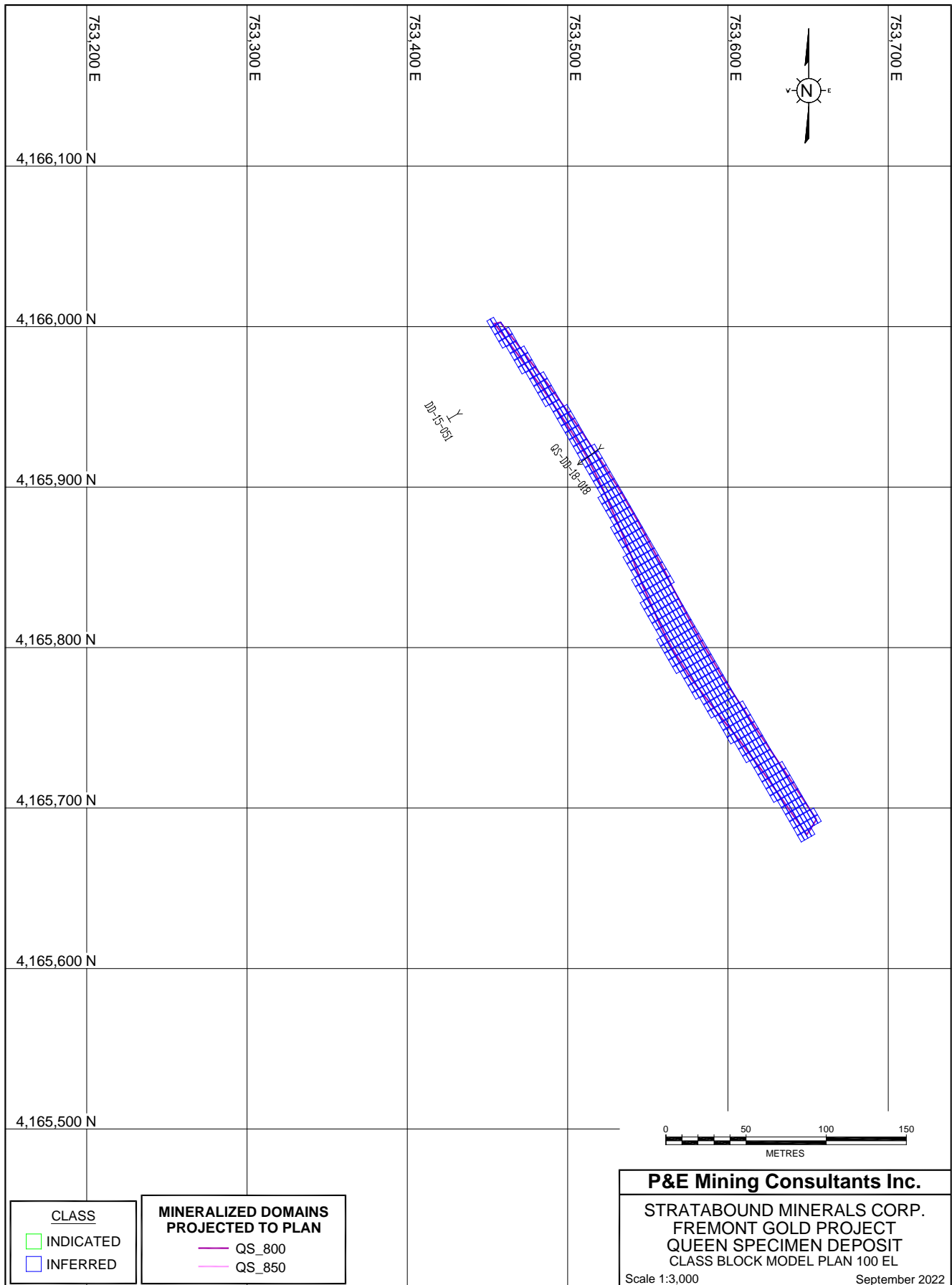

APPENDIX G OPTIMIZED PIT SHELL

FREMONT GOLD PROJECT PINE TREE - JOSEPHINE DEPOSIT OPTIMIZED PIT SHELL

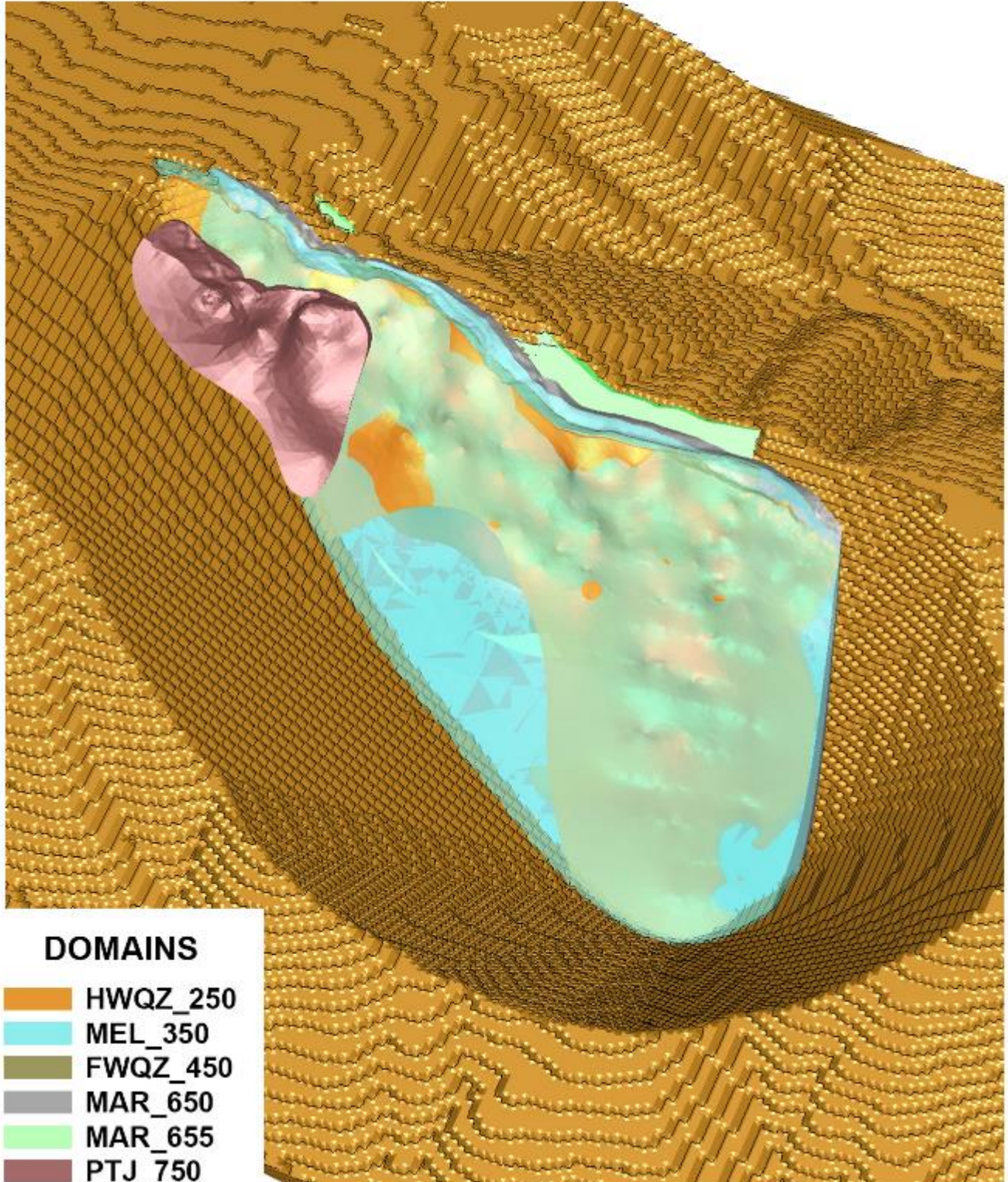

FREMONT GOLD PROJECT QUEEN SPECIMEN DEPOSIT OPTIMIZED PIT SHELL

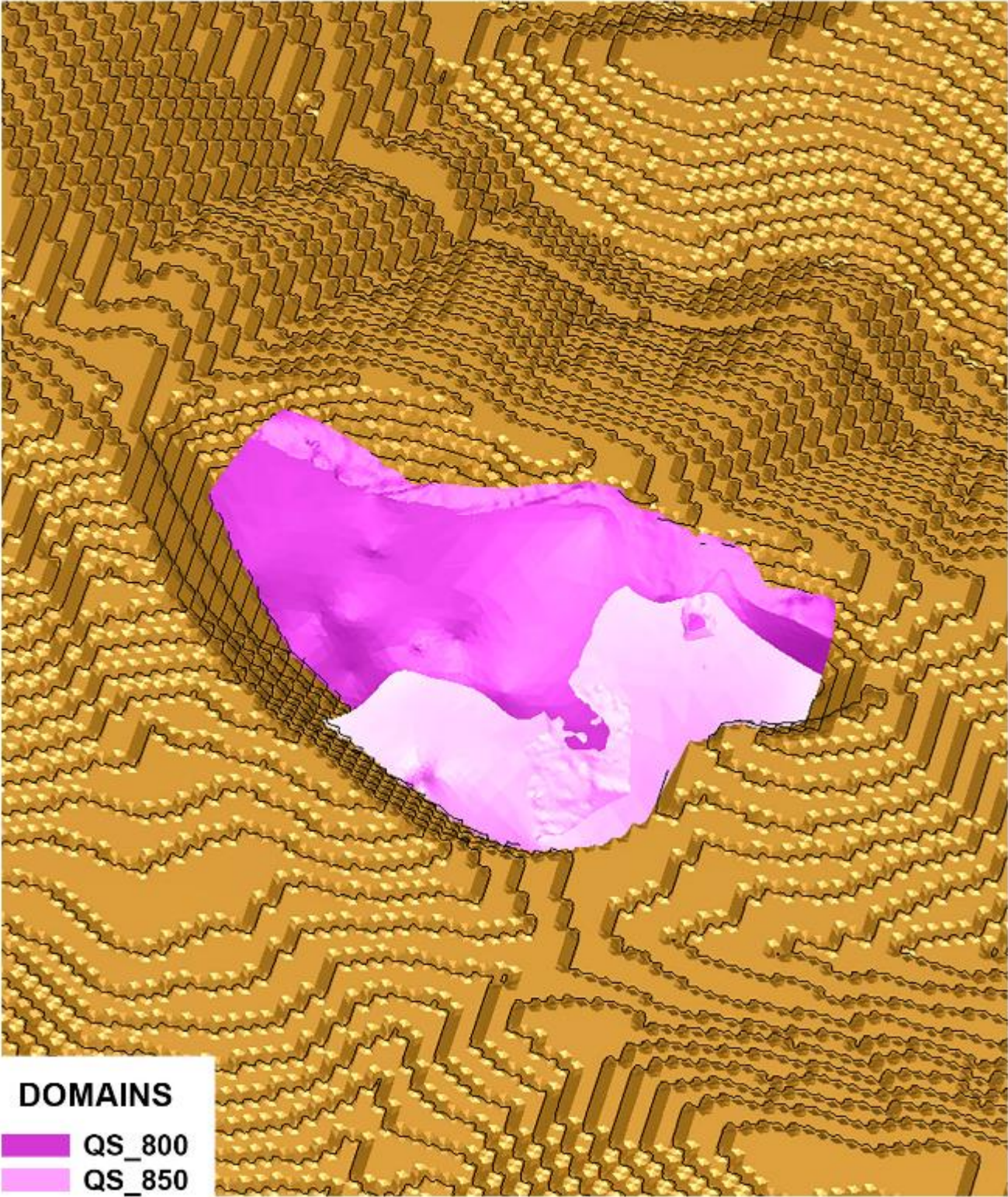

APPENDIX H 1985-1986 DRILL HOLE COLLAR LOCATION AND ORIENTATION

TABLE APPENDIX H-1 1985-1986 DRILL HOLE COLLAR LOCATION AND ORIENTATION DATA						
Drill Hole ID	Northing (ft)	Easting (ft)	Elevation (ft)	Azimuth (deg)	Dip (deg)	Total Depth (ft)
PT-85-RC-1	21,900.24	19,790.86	2,221.00	0	-90	625
PT-85-RC-2	21,901.43	19,671.06	2,229.06	0	-90	440
PT-85-RC-3	22,066.60	19,666.64	2,173.10	0	-90	363
PT-85-RC-4	22,058.50	19,753.76	2,171.01	0	-90	500
PT-85-RC-5	22,000.58	19,840.37	2,165.48	0	-90	620
PT-85-RC-6	21,992.60	19,702.08	2,204.82	0	-90	220
PT-85-RC-7	21,994.83	19,691.64	2,203.81	0	-90	258
PT-85-RC-8	21,499.96	19,676.37	2,250.69	0	-90	500
PT-85-RC-9	21,599.78	19,675.03	2,250.17	0	-90	265
PT-85-RC-10	21,580.40	19,778.48	2,276.56	0	-90	620
PT-85-RC-11	21,499.83	19,763.51	2,277.81	0	-90	660
PT-85-RC-12	21,099.66	19,571.03	2,257.87	0	-90	325
PT-85-RC-13	21,099.04	19,700.25	2,315.97	0	-90	505
PT-85-RC-14	20,999.11	19,696.37	2,334.04	0	-90	580
PT-85-RC-15	20,693.04	19,676.04	2,435.13	0	-90	640
PT-85-RC-16	20,800.01	19,678.90	2,381.09	0	-90	630
PT-85-RC-17	21,099.22	19,804.63	2,340.05	0	-90	725
PT-85-RC-18	20,850.58	19,591.54	2,336.71	0	-90	485
PT-85-RC-19	20,500.03	19,321.93	2,377.89	90	-80	365
PT-85-RC-20	20,190.77	19,362.02	2,307.11	270	-75	445
PT-85-RC-21	21,999.71	19,627.89	2,196.41	0	-90	375
PT-85-RC-22	21,498.46	19,891.62	2,280.22	0	-90	900
PT-85-RC-23	21,902.53	19,888.73	2,169.17	0	-90	725
PT-85-RC-24	21,998.43	19,926.65	2,125.69	0	-90	545
PT-85-RC-25	22,199.02	19,698.85	2,116.06	0	-90	345
PT-85-RC-26	22,199.73	19,898.87	2,066.72	0	-90	437
PT-85-RC-27	22,198.67	19,796.58	2,107.91	0	-90	440
PT-85-RC-28	20,500.00	19,502.10	2,458.87	0	-90	625
PT-85-RC-29	20,203.56	19,501.62	2,464.84	0	-90	645
PT-85-RC-30	20,000.76	19,513.30	2,482.31	0	-90	725
PT-85-RC-31	19,999.75	19,616.07	2,544.74	0	-90	905
PT-85-RC-32	20,499.29	19,601.37	2,501.64	0	-90	845

**TABLE APPENDIX H-1
1985-1986 DRILL HOLE COLLAR LOCATION AND ORIENTATION DATA**

Drill Hole ID	Northing (ft)	Easting (ft)	Elevation (ft)	Azimuth (deg)	Dip (deg)	Total Depth (ft)
PT-85-RC-33	20,201.35	19,601.50	2,510.50	0	-90	905
PT-85-RC-34	19,599.48	19,300.41	2,553.68	0	-90	655
PT-85-RC-35	20,000.39	19,345.70	2,414.73	0	-90	645
PT-85-RC-36	20,100.05	19,368.64	2,392.59	0	-90	460
PT-85-RC-37	20,300.61	19,342.46	2,377.57	0	-90	405
PT-85-RC-38	20,401.13	19,322.48	2,377.68	0	-90	445
PT-85-RC-39	20,601.93	19,355.83	2,363.60	0	-90	300
PT-85-RC-40	20,700.04	19,390.57	2,351.91	0	-90	600
PT-85-RC-41	20,799.57	19,464.98	2,344.31	0	-90	325
PT-85-RC-42	20,924.70	19,646.07	2,330.98	0	-90	525
PT-85-RC-43	20,103.50	19,540.15	2,473.97	0	-90	675
PT-85-RC-44	20,300.42	19,500.56	2,469.91	0	-90	605
PT-85-RC-45	21,901.80	19,606.05	2,214.43	0	-90	570
PT-85-RC-46	21,801.10	19,597.51	2,216.93	0	-90	415
PT-85-RC-47	21,702.41	19,598.65	2,216.46	0	-90	345
PT-85-RC-48	21,602.17	19,605.33	2,219.85	0	-90	525
PT-85-RC-49	21,499.67	19,601.23	2,222.61	0	-90	300
PT-85-RC-50	21,397.49	19,606.20	2,214.30	0	-90	345
PT-85-RC-51	21,298.92	19,626.98	2,218.83	0	-90	400
PT-85-RC-52	21,198.78	19,592.90	2,231.67	0	-90	320
PT-85-RC-53	19,992.88	19,239.61	2,412.17	0	-90	445
PT-85-RC-54	20,499.90	19,297.81	2,378.10	0	-90	285
PT-85-RC-55	20,191.23	19,381.30	2,307.79	0	-90	465
PT-85-RC-56	20,500.26	19,417.91	2,420.82	0	-90	465
PT-85-RC-57	20,600.11	19,433.22	2,426.35	0	-90	455
PT-85-RC-58	20,399.70	19,421.75	2,424.04	0	-90	525
PT-85-RC-59	20,301.23	19,426.02	2,423.66	0	-90	520
PT-85-RC-60	20,198.59	19,443.84	2,427.46	0	-90	540
PT-85-RC-61	20,101.72	19,275.03	2,353.01	0	-90	380
PT-85-RC-62	20,299.85	19,224.73	2,312.56	0	-90	250
PT-85-RC-63	20,199.35	19,191.20	2,305.57	0	-90	325
PT-85-RC-64	22,101.42	19,520.09	2,157.78	0	-90	175
PT-85-RC-65	21,991.06	19,515.82	2,170.96	0	-90	185
PT-85-RC-66	21,900.53	19,524.70	2,176.59	0	-90	230
PT-85-RC-67	20,400.79	19,500.35	2,465.53	0	-90	625
PT-85-RC-68	19,600.89	19,194.33	2,510.26	0	-90	440
PT-85-RC-69	19,898.48	19,347.94	2,463.97	0	-90	505
PT-85-RC-70	19,899.73	19,250.13	2,467.77	0	-90	400

**TABLE APPENDIX H-1
1985-1986 DRILL HOLE COLLAR LOCATION AND ORIENTATION DATA**

Drill Hole ID	Northing (ft)	Easting (ft)	Elevation (ft)	Azimuth (deg)	Dip (deg)	Total Depth (ft)
PT-85-RC-71	19,900.42	19,454.89	2,496.44	0	-90	700
PT-85-RC-72	20,701.80	19,498.69	2,412.98	0	-90	465
PT-85-RC-73	20,599.37	19,524.71	2,450.40	0	-90	575
PT-85-RC-74	21,799.03	19,817.16	2,237.81	0	-90	650
PT-85-RC-75	21,701.10	19,826.47	2,251.00	0	-90	660
PT-85-RC-76	21,600.81	19,861.43	2,266.97	0	-90	760
PT-85-RC-77	21,299.37	19,693.74	2,244.70	0	-90	475
PT-85-RC-78	21,399.70	19,680.64	2,242.63	0	-90	445
PT-85-RC-79	21,000.34	19,474.03	2,257.56	0	-90	235
CP-85-RC-80	24,597.77	19,716.09	1,813.01	0	-90	485
CP-85-RC-81	24,602.78	19,631.44	1,834.45	0	-90	365
CP-85-RC-82	24,599.74	19,544.45	1,869.50	0	-90	325
PT-85-RC-83	21,198.60	19,706.07	2,272.19	0	-90	415
PT-85-RC-84	21,298.21	19,759.16	2,272.22	0	-90	575
PT-85-PT-85	21,397.16	19,763.27	2,273.91	0	-90	600
CP-85-RC-86	24,200.09	19,810.39	1,763.58	0	-90	500
PT-85-RC-87	22,175.40	19,615.68	2,144.31	0	-90	245
PT-RC-86-88	24,202.60	19,700.74	1,725.55	0	-90	345
PT-RC-86-89	24,196.22	19,610.97	1,722.80	0	-90	205
PT-RC-86-90	21,399.47	19,865.19	2,294.12	0	-90	795
PT-RC-86-91	20,709.01	19,600.54	2,416.79	0	-90	585
PT-RC-86-92	20,900.88	19,527.51	2,305.19	0	-90	355
PT-RC-86-93	20,999.12	19,579.17	2,290.29	0	-90	380
PT-RC-86-94	21,300.98	19,882.26	2,305.32	0	-90	800
PT-RC-86-95	21,198.21	19,804.52	2,306.34	0	-90	680
CP-RC-86-96	23,599.51	19,750.32	1,782.80	0	-90	365
CP-RC-86-97	23,597.08	19,660.76	1,801.97	0	-90	300
CP-RC-86-98	23,604.20	19,859.41	1,776.13	0	-90	295
CP-RC-86-99	23,599.54	20,027.91	1,826.11	0	-90	665
PT-RC-86-100	22,299.00	19,749.67	2,067.14	0	-90	325
PT-RC-86-101	20,799.49	19,406.80	2,330.30	0	-90	300
PT-RC-86-102	21,604.34	19,711.18	2,260.54	0	-90	580
PT-RC-86-103	21,799.27	19,710.44	2,248.61	0	-90	580
PT-RC-86-104	19,772.32	19,170.73	2,506.06	0	-90	400
PT-RC-86-105	19,804.69	19,288.34	2,510.84	0	-90	525
PT-RC-86-106	19,002.63	19,397.88	2,508.51	0	-90	625
CG-RC-86107	15,997.44	18,562.80	2,332.71	0	-90	405
CG-RC-86108	15,995.15	18,661.10	2,359.64	0	-90	525

**TABLE APPENDIX H-1
1985-1986 DRILL HOLE COLLAR LOCATION AND ORIENTATION DATA**

Drill Hole ID	Northing (ft)	Easting (ft)	Elevation (ft)	Azimuth (deg)	Dip (deg)	Total Depth (ft)
CG-RC-86109	15,998.01	18,501.64	2,311.88	0	-90	305
CG-RC-86110	15,997.89	18,984.20	2,447.29	0	-90	885
CG-RC-86111	15,993.40	18,772.62	2,379.32	0	-90	570
CG-RC-86112	15,997.35	18,885.65	2,418.07	0	-90	425
PT-RC-86-113	20,002.27	19,151.50	2,393.30	0	-90	175
PT-RC-86-114	19,991.71	19,255.94	2,412.37	0	-90	60
PT-RC-86-115	20,201.42	19,295.22	2,347.40	0	-90	250
PT-RC-86-116	20,098.54	19,177.30	2,336.21	0	-90	160
PT-RC-86-117	20,299.54	19,139.05	2,275.15	0	-90	125
PT-RC-86-118	19,891.87	19,082.64	2,435.54	0	-90	160
PT-RC-86-119	21,200.78	19,900.78	2,328.08	0	-90	875
PT-RC-86-120	21,695.19	19,899.39	2,227.42	0	-90	805
CG-RC-86-121	16,999.76	18,874.56	2,419.89	0	-90	340
CG-RC-86-122	17,003.49	18,961.66	2,457.47	0	-90	605
CG-RC-86-123	17,002.31	18,877.63	2,499.07	0	-90	860
PT-RC-86-124	20,699.43	19,300.23	2,300.76	0	-90	195
PT-RC-86-125	20,898.91	19,401.36	2,286.53	0	-90	225
PT-RC-86-126	21,800.30	19,536.36	2,185.33	0	-90	265
PT-RC-86-127	21,700.05	19,550.49	2,195.43	0	-90	275
PT-RC-86-128	20,588.81	19,229.56	2,318.04	0	-90	185
PT-RC-86-129	22,288.36	19,644.27	2,083.58	0	-90	185
PT-RC-86-130	22,300.60	19,843.56	2,049.41	0	-90	365
PT-RC-86-131	21,798.93	19,902.33	2,194.40	0	-90	590
PT-RC-86-132	21,788.25	19,908.19	2,195.10	0	-90	675
QS-RC-86-133	25,995.48	20,202.27	1,420.84	0	-90	380
QS-RC-86-134	26,999.80	19,993.09	1,321.61	0	-90	265
QS-RC-86-135	25,998.24	19,994.75	1,443.42	0	-90	195
QS-RC-86-136	26,200.71	20,194.55	1,361.29	0	-90	350
QS-RC-86-137	25,800.48	20,192.01	1,483.87	0	-90	375
QS-RC-86-138	26,000.39	20,102.71	1,404.33	0	-90	535
QS-RC-86-139	26,400.31	20,199.11	1,299.10	0	-90	325
QS-RC-86-140	26,999.83	20,199.69	1,230.05	0	-90	400

Source: Burgoyne (2013)

APPENDIX I 1985-1986 DRILL HOLE INTERCEPTS

<p align="center">TABLE APPEND I-1 SIGNIFICANT 1985-1986 DRILL HOLE INTERCEPTS *</p>							
Drill Hole ID	Structure	From (ft)	To (ft)	Width (ft)	Au (oz/ton)	Section (North)	Oxide
PT-85-RC-1	Melones Fault	345	365	20	0.094	21,900	oxide
PT-85-RC-1	Melones Fault	430	475	45	0.087	21,900	
PT-85-RC-1	Melones Fault	495	510	15	0.042	21,900	
PT-85-RC-1	Melones Fault	530	550	20	0.096	21,900	
PT-85-RC-2	Melones Fault	135	155	20	0.066	21,900	oxide
PT-85-RC-2	Melones Fault	215	230	15	0.088	21,900	
PT-85-RC-2	Melones Fault	255	295	40	0.054	21,900	
PT-85-RC-2	Melones Fault	305	320	15	0.058	21,900	
PT-85-RC-2	Melones Fault	330	353	23	0.144	21,900	
PT-85-RC-2	Melones Fault	385	405	20	0.092	21,900	
PT-85-RC-3	Melones Fault	125	150	25	0.134	22,100	
PT-85-RC-3	Melones Fault	215	270	55	0.117	22,100	
PT-85-RC-3	Melones Fault	295	325	30	0.069	22,100	
PT-85-RC-4	Melones Fault	200	210	10	0.055	22,100	
PT-85-RC-4	Melones Fault	260	300	40	0.185	22,100	
PT-85-RC-4	Melones Fault	350	375	25	0.045	22,100	
PT-85-RC-5	Melones Fault	260	277	17	0.060	22,000	
PT-85-RC-5	Melones Fault	300	360	60	0.057	22,000	
PT-85-RC-5	Melones Fault	380	415	35	0.156	22,000	
PT-85-RC-5	Melones Fault	435	600	165	0.082	22,000	
PT-85-RC-6	Melones Fault	150	181	31	0.145	22,000	
PT-85-RC-6	Melones Fault	202	220	18	0.053	22,000	
PT-85-RC-7	Melones Fault	145	180	35	0.154	22,000	
PT-85-RC-7	Melones Fault	203	255	52	0.088	22,000	
PT-85-RC-8	Melones Fault	195	275	80	0.073	21,500	
PT-85-RC-8	Melones Fault	285	295	10	0.061	21,500	
PT-85-RC-8	Melones Fault	345	360	15	0.157	21,500	
PT-85-RC-8	Melones Fault	415	425	10	0.041	21,500	
PT-85-RC-8	Melones Fault	445	455	10	0.075	21,500	
PT-85-RC-9	Melones Fault	210	220	10	0.034	21,600	oxide
PT-85-RC-9	Melones Fault	235	245	10	0.051	21,600	oxide
PT-85-RC-10	Melones Fault	330	340	10	0.071	21,600	
PT-85-RC-10	Melones Fault	380	395	15	0.093	21,600	

**TABLE APPEND I-1
SIGNIFICANT 1985-1986 DRILL HOLE INTERCEPTS ***

Drill Hole ID	Structure	From (ft)	To (ft)	Width (ft)	Au (oz/ton)	Section (North)	Oxide
PT-85-RC-10	Melones Fault	465	480	15	0.156	21,600	
PT-85-RC-10	Melones Fault	490	535	45	0.063	21,600	
PT-85-RC-10	Melones Fault	545	600	55	0.065	21,600	
PT-85-RC-11	Melones Fault	375	385	10	0.059	21,500	
PT-85-RC-11	Melones Fault	470	480	10	0.038	21,500	
PT-85-RC-11	Melones Fault	555	570	15	0.047	21,500	
PT-85-RC-12	Melones Fault	110	120	10	0.128	21,100	oxide
PT-85-RC-12	Melones Fault	160	180	20	0.057	21,100	
PT-85-RC-12	Melones Fault	200	265	65	0.063	21,100	
PT-85-RC-13	Melones Fault	400	465	65	0.069	21,100	
PT-85-RC-14	Melones Fault	335	380	45	0.154	21,000	
PT-85-RC-14	Melones Fault	445	465	20	0.039	21,000	
PT-85-RC-14	Melones Fault	480	530	50	0.077	21,000	
PT-85-RC-15	Melones Fault	540	550	10	0.041	20,700	
PT-85-RC-15	Melones Fault	565	600	35	0.065	20,700	
PT-85-RC-16	Melones Fault	415	425	10	0.084	20,800	
PT-85-RC-16	Melones Fault	550	620	70	0.070	20,800	
PT-85-RC-17	Melones Fault	555	605	50	0.172	21,100	
PT-85-RC-17	Melones Fault	630	665	35	0.077	21,100	
PT-85-RC-17	Melones Fault	700	720	20	0.086	21,100	
PT-85-RC-18	Melones Fault	225	245	20	0.039	20,900	
PT-85-RC-18	Melones Fault	290	320	30	0.155	20,900	
PT-85-RC-18	Melones Fault	345	410	39	0.086	20,900	
PT-85-RC-19	Melones Fault	100	135	35	0.102	20,500	oxide
PT-85-RC-19	Melones Fault	190	210	20	0.129	20,500	
PT-85-RC-19	Melones Fault	245	275	30	0.244	20,500	
PT-85-RC-19	Melones Fault	285	300	15	0.114	20,500	
PT-85-RC-20	Melones Fault	85	110	25	0.396	20,200	
PT-85-RC-20	Melones Fault	130	170	40	0.047	20,200	
PT-85-RC-20	Melones Fault	195	205	10	0.087	20,200	
PT-85-RC-20	Melones Fault	210	290	80	0.107	20,200	
PT-85-RC-20	Melones Fault	305	335	30	0.081	20,200	
PT-85-RC-21	Melones Fault	65	103	38	0.129	22,000	
PT-85-RC-21	Melones Fault	215	225	10	0.032	22,000	
PT-85-RC-21	Melones Fault	270	315	45	0.086	22,000	
PT-85-RC-22	Melones Fault	645	670	25	0.160	21,500	
PT-85-RC-22	Melones Fault	735	770	35	0.070	21,500	
PT-85-RC-23	Melones Fault	435	450	15	0.275	21,900	
PT-85-RC-23	Melones Fault	510	520	10	0.050	21,900	

**TABLE APPEND I-1
SIGNIFICANT 1985-1986 DRILL HOLE INTERCEPTS ***

Drill Hole ID	Structure	From (ft)	To (ft)	Width (ft)	Au (oz/ton)	Section (North)	Oxide
PT-85-RC-23	Melones Fault	535	545	10	0.121	21,900	
PT-85-RC-23	Melones Fault	560	580	20	0.059	21,900	
PT-85-RC-23	Melones Fault	650	705	55	0.059	21,900	
PT-85-RC-24	Melones Fault	470	535	65	0.117	22,000	oxide
PT-85-RC-25	Melones Fault	0	10	10	0.037	22,200	
PT-85-RC-25	Melones Fault	85	135	50	0.062	22,200	
PT-85-RC-25	Melones Fault	235	265	30	0.044	22,200	
PT-85-RC-26	Melones Fault	275	285	10	0.030	22,200	
PT-85-RC-26	Melones Fault	400	410	10	0.032	22,200	
PT-85-RC-26	Melones Fault	420	437	17	0.031	22,200	
PT-85-RC-27	Melones Fault	220	265	45	0.066	22,200	
PT-85-RC-27	Melones Fault	360	370	10	0.030	22,200	
PT-85-RC-28	Melones Fault	320	340	20	0.057	20,500	
PT-85-RC-28	Melones Fault	380	390	10	0.096	20,500	
PT-85-RC-28	Melones Fault	500	550	50	0.077	20,500	
PT-85-RC-29	Melones Fault	95	105	10	0.047	20,200	oxide
PT-85-RC-29	Melones Fault	440	460	20	0.109	20,200	
PT-85-RC-29	Melones Fault	470	530	60	0.065	20,200	
PT-85-RC-29	Melones Fault	545	585	40	0.065	20,200	
PT-85-RC-30	Melones Fault	0	10	10	0.045	20,000	oxide
PT-85-RC-30	Melones Fault	115	160	45	0.044	20,000	
PT-85-RC-30	Melones Fault	200	230	30	0.035	20,000	
PT-85-RC-30	Melones Fault	500	530	30	0.044	20,000	
PT-85-RC-30	Melones Fault	540	555	15	0.066	20,000	
PT-85-RC-30	Melones Fault	570	600	30	0.061	20,000	
PT-85-RC-31	Melones Fault	50	65	15	0.032	20,000	oxide
PT-85-RC-31	Melones Fault	165	185	20	0.065	20,000	
PT-85-RC-31	Melones Fault	685	695	10	0.040	20,000	
PT-85-RC-31	Melones Fault	705	725	20	0.037	20,000	
PT-85-RC-31	Melones Fault	770	800	10	0.094	20,000	
PT-85-RC-32	Melones Fault	490	500	10	0.045	20,500	
PT-85-RC-32	Melones Fault	535	545	10	0.032	20,500	
PT-85-RC-32	Melones Fault	615	625	10	0.045	20,500	
PT-85-RC-32	Melones Fault	645	690	45	0.058	20,500	
PT-85-RC-33	Melones Fault	80	95	15	0.041	20,200	
PT-85-RC-33	Melones Fault	295	305	10	0.042	20,200	
PT-85-RC-33	Melones Fault	585	640	55	0.094	20,200	
PT-85-RC-33	Melones Fault	715	760	45	0.064	20,200	
PT-85-RC-34	Melones Fault	390	410	20	0.047	19,600	

**TABLE APPEND I-1
SIGNIFICANT 1985-1986 DRILL HOLE INTERCEPTS ***

Drill Hole ID	Structure	From (ft)	To (ft)	Width (ft)	Au (oz/ton)	Section (North)	Oxide
PT-85-RC-34	Melones Fault	435	450	15	0.032	19,600	
PT-85-RC-34	Melones Fault	625	635	10	0.076	19,600	
PT-85-RC-35	Melones Fault	250	260	10	0.033	20,000	
PT-85-RC-35	Melones Fault	280	305	25	0.121	20,000	
PT-85-RC-35	Melones Fault	340	355	15	0.043	20,000	
PT-85-RC-35	Melones Fault	415	425	10	0.031	20,000	
PT-85-RC-35	Melones Fault	435	450	15	0.121	20,000	
PT-85-RC-36	Melones Fault	140	160	20	0.069	20,100	
PT-85-RC-36	Melones Fault	210	260	50	0.109	20,100	
PT-85-RC-36	Melones Fault	295	310	15	0.094	20,100	
PT-85-RC-36	Melones Fault	320	340	20	0.178	20,100	
PT-85-RC-36	Melones Fault	395	415	20	0.067	20,100	
PT-85-RC-37	Melones Fault	90	155	65	0.106	20,300	
PT-85-RC-37	Melones Fault	180	195	15	0.033	20,300	
PT-85-RC-37	Melones Fault	215	225	10	0.057	20,300	
PT-85-RC-37	Melones Fault	255	265	10	0.036	20,300	
PT-85-RC-37	Melones Fault	310	325	15	0.051	20,300	
PT-85-RC-38	Melones Fault	100	110	10	0.036	20,400	
PT-85-RC-38	Melones Fault	205	220	15	0.084	20,400	
PT-85-RC-38	Melones Fault	280	300	20	0.071	20,400	
PT-85-RC-39	Melones Fault	100	135	35	0.084	20,600	
PT-85-RC-39	Melones Fault	210	240	30	0.057	20,600	
PT-85-RC-40	Melones Fault	135	170	35	0.305	20,700	
PT-85-RC-40	Melones Fault	200	260	60	0.096	20,700	
PT-85-RC-40	Melones Fault	405	460	55	0.035	20,700	
PT-85-RC-40	Melones Fault	540	560	20	0.037	20,700	
PT-85-RC-41	Melones Fault	205	260	55	0.105	20,800	
PT-85-RC-41	Melones Fault	270	280	10	0.025	20,800	
PT-85-RC-42	Melones Fault	445	475	30	0.085	20,900	
PT-85-RC-43	Melones Fault	70	95	25	0.034	20,100	
PT-85-RC-43	Melones Fault	110	140	30	0.039	20,100	
PT-85-RC-43	Melones Fault	150	160	10	0.033	20,100	
PT-85-RC-43	Melones Fault	175	230	55	0.037	20,100	
PT-85-RC-43	Melones Fault	635	655	20	0.032	20,100	
PT-85-RC-44	Melones Fault	360	390	30	0.068	20,300	
PT-85-RC-44	Melones Fault	415	430	15	0.049	20,300	
PT-85-RC-44	Melones Fault	445	460	15	0.086	20,300	
PT-85-RC-44	Melones Fault	470	515	45	0.158	20,300	
PT-85-RC-44	Melones Fault	545	570	25	0.042	20,300	

**TABLE APPEND I-1
SIGNIFICANT 1985-1986 DRILL HOLE INTERCEPTS ***

Drill Hole ID	Structure	From (ft)	To (ft)	Width (ft)	Au (oz/ton)	Section (North)	Oxide
PT-85-RC-45	Melones Fault	65	80	15	0.094	21,900	oxide
PT-85-RC-45	Melones Fault	225	240	15	0.033	21,900	
PT-85-RC-45	Melones Fault	265	280	15	0.047	21,900	
PT-85-RC-45	Melones Fault	305	315	10	0.086	21,900	
PT-85-RC-46	Melones Fault	75	90	15	0.312	21,800	oxide
PT-85-RC-46	Melones Fault	125	145	20	0.041	21,800	oxide
PT-85-RC-47	Melones Fault	200	210	10	0.038	21,700	
PT-85-RC-47	Melones Fault	240	275	35	0.052	21,700	
PT-85-RC-48	Melones Fault	85	95	10	0.038	21,600	oxide
PT-85-RC-48	Melones Fault	135	175	40	0.059	21,600	oxide
PT-85-RC-48	Melones Fault	220	230	10	0.065	21,600	
PT-85-RC-48	Melones Fault	260	285	25	0.039	21,600	
PT-85-RC-49	Melones Fault	80	90	10	0.070	21,500	oxide
PT-85-RC-49	Melones Fault	105	115	10	0.041	21,500	oxide
PT-85-RC-49	Melones Fault	150	175	25	0.051	21,500	oxide
PT-85-RC-49	Melones Fault	250	280	30	0.065	21,500	
PT-85-RC-50	Melones Fault	175	205	30	0.039	21,400	oxide
PT-85-RC-50	Melones Fault	235	250	15	0.067	21,400	
PT-85-RC-50	Melones Fault	295	325	30	0.056	21,400	
PT-85-RC-51	Melones Fault	130	140	10	0.030	21,300	
PT-85-RC-51	Melones Fault	215	245	30	0.063	21,300	
PT-85-RC-51	Melones Fault	260	280	20	0.057	21,300	
PT-85-RC-51	Melones Fault	290	320	30	0.056	21,300	
PT-85-RC-51	Melones Fault	330	340	10	0.102	21,300	
PT-85-RC-51	Melones Fault	350	365	15	0.061	21,300	
PT-85-RC-52	Melones Fault	205	240	35	0.039	21,200	
PT-85-RC-52	Melones Fault	255	270	15	0.069	21,200	
PT-85-RC-52	Melones Fault	285	305	20	0.036	21,200	
PT-85-RC-53	Melones Fault	80	115	35	0.038	20,000	oxide
PT-85-RC-53	Melones Fault	145	165	20	0.059	20,000	
PT-85-RC-53	Melones Fault	335	350	15	0.062	20,000	
PT-85-RC-53	Melones Fault	370	380	10	0.044	20,000	
PT-85-RC-53	Melones Fault	415	425	10	0.037	20,000	
PT-85-RC-54	Melones Fault	180	200	20	0.067	20,500	oxide
PT-85-RC-54	Melones Fault	215	235	20	0.088	20,500	
PT-85-RC-55	Melones Fault	130	140	10	0.186	20,200	
PT-85-RC-55	Melones Fault	150	175	25	0.070	20,200	
PT-85-RC-55	Melones Fault	190	270	80	0.051	20,200	
PT-85-RC-55	Melones Fault	285	390	105	0.063	20,200	

**TABLE APPEND I-1
SIGNIFICANT 1985-1986 DRILL HOLE INTERCEPTS ***

Drill Hole ID	Structure	From (ft)	To (ft)	Width (ft)	Au (oz/ton)	Section (North)	Oxide
PT-85-RC-56	Melones Fault	195	210	15	0.063	20,500	
PT-85-RC-56	Melones Fault	260	285	25	0.086	20,500	
PT-85-RC-56	Melones Fault	310	375	65	0.074	20,500	
PT-85-RC-57	Melones Fault	205	235	30	0.221	20,600	
PT-85-RC-58	Melones Fault	190	255	65	0.137	20,400	
PT-85-RC-58	Melones Fault	270	285	15	0.030	20,400	
PT-85-RC-58	Melones Fault	295	315	20	0.041	20,400	
PT-85-RC-58	Melones Fault	390	445	55	0.218	20,400	
PT-85-RC-59	Melones Fault	205	355	150	0.067	20,300	
PT-85-RC-59	Melones Fault	370	455	85	0.077	20,300	
PT-85-RC-60	Melones Fault	270	300	30	0.034	20,200	
PT-85-RC-60	Melones Fault	330	400	70	0.102	20,200	
PT-85-RC-60	Melones Fault	465	510	45	0.062	20,200	
PT-85-RC-61	Melones Fault	15	100	85	0.043	20,100	oxide
PT-85-RC-61	Melones Fault	205	220	15	0.032	20,100	
PT-85-RC-61	Melones Fault	245	255	10	0.212	20,100	
PT-85-RC-61	Melones Fault	265	275	10	0.043	20,100	
PT-85-RC-61	Melones Fault	350	360	10	0.053	20,100	
PT-85-RC-62	Melones Fault	5	20	15	0.038	20,300	oxide
PT-85-RC-62	Melones Fault	155	190	35	0.070	20,300	
PT-85-RC-63	Melones Fault	150	160	10	0.042	20,200	
PT-85-RC-63	Melones Fault	170	185	15	0.071	20,200	
PT-85-RC-63	Melones Fault	280	295	15	0.036	20,200	
PT-85-RC-64	Melones Fault	15	30	15	0.047	22,100	
PT-85-RC-64	Melones Fault	120	150	30	0.041	22,100	
PT-85-RC-65	Melones Fault	0	10	10	0.039	22,000	oxide
PT-85-RC-65	Melones Fault	25	35	10	0.044	22,000	oxide
PT-85-RC-65	Melones Fault	45	60	15	0.086	22,000	oxide
PT-85-RC-65	Melones Fault	120	170	50	0.062	22,000	
PT-85-RC-66	Melones Fault	60	70	10	0.082	21,900	oxide
PT-85-RC-66	Melones Fault	115	145	30	0.057	21,900	
PT-85-RC-66	Melones Fault	185	195	10	0.076	21,900	
PT-85-RC-67	Melones Fault	325	385	60	0.090	20,400	
PT-85-RC-67	Melones Fault	425	435	10	0.033	20,400	
PT-85-RC-67	Melones Fault	470	545	75	0.084	20,400	
PT-85-RC-68	Melones Fault	210	235	25	0.054	19,600	
PT-85-RC-69	Melones Fault	260	290	30	0.046	19,900	
PT-85-RC-69	Melones Fault	320	345	25	0.050	19,900	
PT-85-RC-69	Melones Fault	495	505	10	0.145	19,900	

**TABLE APPEND I-1
SIGNIFICANT 1985-1986 DRILL HOLE INTERCEPTS ***

Drill Hole ID	Structure	From (ft)	To (ft)	Width (ft)	Au (oz/ton)	Section (North)	Oxide
PT-85-RC-70	Melones Fault	150	172	22	0.129	19,900	
PT-85-RC-70	Melones Fault	190	200	10	0.040	19,900	
PT-85-RC-70	Melones Fault	235	275	40	0.158	19,900	
PT-85-RC-71	Melones Fault	620	690	70	0.097	19,900	
PT-85-RC-72	Melones Fault	245	270	25	0.125	20,700	
PT-85-RC-72	Melones Fault	285	300	15	0.280	20,700	
PT-85-RC-72	Melones Fault	318	390	72	0.097	20,700	
PT-85-RC-72	Melones Fault	400	410	10	0.040	20,700	
PT-85-RC-73	Melones Fault	310	355	45	0.080	20,600	
PT-85-RC-73	Melones Fault	385	445	60	0.127	20,600	
PT-85-RC-73	Melones Fault	460	500	40	0.100	20,600	
PT-85-RC-74	Melones Fault	400	485	85	0.088	21,800	
PT-85-RC-74	Melones Fault	500	525	25	0.087	21,800	
PT-85-RC-74	Melones Fault	575	610	35	0.089	21,800	
PT-85-RC-75	Melones Fault	395	405	10	0.067	21,700	
PT-85-RC-75	Melones Fault	460	490	30	0.069	21,700	
PT-85-RC-75	Melones Fault	565	620	55	0.105	21,700	
PT-85-RC-76	Melones Fault	555	575	20	0.058	21,600	
PT-85-RC-76	Melones Fault	625	640	15	0.121	21,600	
PT-85-RC-76	Melones Fault	670	690	20	0.143	21,600	
PT-85-RC-77	Melones Fault	310	320	10	0.057	21,300	
PT-85-RC-77	Melones Fault	345	365	20	0.173	21,300	
PT-85-RC-77	Melones Fault	380	410	30	0.104	21,300	
PT-85-RC-78	Melones Fault	240	275	35	0.051	21,400	oxide
PT-85-RC-78	Melones Fault	320	330	10	0.193	21,400	oxide
PT-85-RC-78	Melones Fault	375	430	55	0.061	21,400	
PT-85-RC-79	Melones Fault	70	155	85	0.073	21,000	
PT-85-RC-79	Melones Fault	165	175	10	0.054	21,000	
CP-85-RC-80	Melones Fault						
CP-85-RC-81	Melones Fault	160	170	10	0.036	24,600	
CP-85-RC-82	Melones Fault						
CP-85-RC-83	Melones Fault	390	400	10	0.137	21,200	
CP-85-RC-84	Melones Fault	380	415	35	0.045	21,300	
CP-85-RC-84	Melones Fault	470	530	60	0.083	21,300	
PT-85-RC-85	Melones Fault	385	405	20	0.126	21,400	
PT-85-RC-85	Melones Fault	460	550	90	0.127	21,400	
CP-85-RC-86	Melones Fault						
CP-85-RC-87	Melones Fault	35	100	65	0.066	22,200	oxide
CP-85-RC-87	Melones Fault	135	185	50	0.047	22,200	

**TABLE APPEND I-1
SIGNIFICANT 1985-1986 DRILL HOLE INTERCEPTS ***

Drill Hole ID	Structure	From (ft)	To (ft)	Width (ft)	Au (oz/ton)	Section (North)	Oxide
PT-RC-86-88	Melones Fault						
PT-RC-86-89	Melones Fault						
PT-RC-86-90	Melones Fault	655	710	55	0.086	21,400	
PT-RC-86-91	Melones Fault	395	410	15	0.037	20,700	
PT-RC-86-91	Melones Fault	420	550	130	0.078	20,700	
PT-RC-86-92	Melones Fault	120	135	15	0.028	20,900	
PT-RC-86-92	Melones Fault	165	290	125	0.150	20,900	
PT-RC-86-93	Melones Fault	160	170	10	0.045	21,000	
PT-RC-86-93	Melones Fault	245	320	75	0.107	21,000	
CP-RC-86-94	Crown Point	550	560	10	0.059	21,300	
CP-RC-86-94	Crown Point	625	650	25	0.071	21,300	
CP-RC-86-94	Crown Point	675	740	65	0.143	21,300	
CP-RC-86-94	Crown Point	760	770	10	0.126	21,300	
CP-RC-86-95	Crown Point	515	530	15	0.076	21,200	
CP-RC-86-95	Crown Point	545	555	10	0.175	21,200	
CP-RC-86-95	Crown Point	580	650	70	0.159	21,200	
CP-RC-86-96	Crown Point						
CP-RC-86-97	Crown Point						
CP-RC-86-98	Crown Point						
CP-RC-86-99	Crown Point						
PT-RC-86-100	Melones Fault	65	90	25	0.062	22,300	
PT-RC-86-100	Melones Fault	115	130	15	0.067	22,300	
PT-RC-86-101	Melones Fault	80	95	15	0.084	20,800	oxide
PT-RC-86-101	Melones Fault	140	195	55	0.090	20,800	
PT-RC-86-101	Melones Fault	205	215	10	0.049	20,800	
PT-RC-86-102	Melones Fault	380	395	15	0.052	21,700	
PT-RC-86-102	Melones Fault	430	450	20	0.077	21,700	
PT-RC-86-102	Melones Fault	480	495	15	0.054	21,700	
PT-RC-86-103	Melones Fault	235	255	20	0.197	21,800	oxide
PT-RC-86-103	Melones Fault	435	470	35	0.182	21,800	
PT-RC-86-103	Melones Fault	485	495	10	0.057	21,800	
PT-RC-86-104	Melones Fault	5	15	10	0.045	19,800	oxide
PT-RC-86-104	Melones Fault	25	40	15	0.072	19,800	oxide
PT-RC-86-104	Melones Fault	55	70	15	0.051	19,800	oxide
PT-RC-86-105	Melones Fault	265	275	10	0.082	19,800	
PT-RC-86-105	Melones Fault	375	390	15	0.086	19,800	
PT-RC-86-105	Melones Fault	445	470	25	0.095	19,800	
PT-RC-86-106	Melones Fault	310	355	45	0.072	19,800	
CG-RC-86107	Melones Chicken Gulch	225	235	10	0.044	16,000	

**TABLE APPEND I-1
SIGNIFICANT 1985-1986 DRILL HOLE INTERCEPTS ***

Drill Hole ID	Structure	From (ft)	To (ft)	Width (ft)	Au (oz/ton)	Section (North)	Oxide
CG-RC-86108	Melones Chicken Gulch						
CG-RC-86109	Melones Chicken Gulch						
CG-RC-86110	Melones Chicken Gulch	465	495	30	0.061	16,000	
CG-RC-86110	Melones Chicken Gulch	610	625	15	0.068	16,000	
CG-RC-86-111	Melones Chicken Gulch	270	360	90	0.063	16,000	
CG-RC-86-112	Melones Chicken Gulch	10	25	15	0.050	16,000	
CG-RC-86-112	Melones Chicken Gulch	35	45	10	0.039	16,000	
PT-RC-86-113	Melones Fault	40	63	23	0.117		oxide
PT-RC-86-113	Melones Fault	69	90	21	0.199	20,000	
PT-RC-86-114	Melones Fault	10	20	10	0.034	20,000	
PT-RC-86-115	Melones Fault	40	60	20	0.060		oxide
PT-RC-86-115	Melones Fault	75	95	20	0.043		oxide
PT-RC-86-115	Melones Fault	130	140	10	0.089	20,200	
PT-RC-86-115	Melones Fault	165	250	85	0.107	20,200	
PT-RC-86-116	Melones Fault	30	52	22	0.095		oxide
PT-RC-86-116	Melones Fault	80	90	10	0.049	20,100	
PT-RC-86-117	Melones Fault	0	20	20	0.123	20,300	
PT-RC-86-118	Melones Fault	105	130	25	0.037	19,900	
PT-RC-86-119	Melones Fault	510	520	10	0.102	21,200	
PT-RC-86-119	Melones Fault	730	775	45	0.087	21,200	
PT-RC-86-119	Melones Fault	785	795	10	0.032	21,200	
PT-RC-86-119	Melones Fault	850	870	20	0.076	21,200	
PT-RC-86-120	Melones Fault	720	730	10	0.087	21,700	
CG-RC-86-121	Melones Chicken Gulch						
CG-RC-86-122	Melones Chicken Gulch	95	105	10	0.092	17,000	
CG-RC-86-122	Melones Chicken Gulch	320	330	10	0.071	17,000	
CG-RC-86-122	Melones Chicken Gulch	525	545	20	0.129	17,000	
CG-RC-86-123	Melones Chicken Gulch	130	155	25	0.133	17,000	
CG-RC-86-123	Melones Chicken Gulch	230	250	20	0.063	17,000	
CG-RC-86-123	Melones Chicken Gulch	275	295	20	0.051	17,000	
CG-RC-86-123	Melones Chicken Gulch	800	810	10	0.117	17,000	
CG-RC-86-123	Melones Chicken Gulch	830	840	10	0.166	17,000	
PT-RC-86-124	Melones Fault	35	75	40	0.122	20,700	oxide
PT-RC-86-124	Melones Fault	135	155	20	0.063	20,700	
PT-RC-86-125	Melones Fault	25	35	10	0.058	20,900	oxide
PT-RC-86-125	Melones Fault	60	75	15	0.075	20,900	oxide
PT-RC-86-125	Melones Fault	100	130	30	0.076	20,900	oxide
PT-RC-86-125	Melones Fault	140	160	20	0.037	20,900	oxide
PT-RC-86-126	Melones Fault	5	15	10	0.148	21,800	oxide

**TABLE APPEND I-1
SIGNIFICANT 1985-1986 DRILL HOLE INTERCEPTS ***

Drill Hole ID	Structure	From (ft)	To (ft)	Width (ft)	Au (oz/ton)	Section (North)	Oxide
PT-RC-86-126	Melones Fault	85	105	20	0.060	21,800	oxide
PT-RC-86-126	Melones Fault	165	180	15	0.058	21,800	
PT-RC-86-126	Melones Fault	195	235	40	0.072	21,800	
PT-RC-86-127	Melones Fault	25	50	25	0.046	21,700	oxide
PT-RC-86-127	Melones Fault	120	155	35	0.058	21,700	oxide
PT-RC-86-127	Melones Fault	185	205	20	0.054	21,700	
PT-RC-86-127	Melones Fault	220	240	20	0.034	21,700	
PT-RC-86-128	Melones Fault	35	55	20	0.118	20,600	oxide
PT-RC-86-128	Melones Fault	65	80	15	0.066	20,600	oxide
PT-RC-86-129	Melones Fault						
PT-RC-86-130	Melones Fault	230	240	10	0.045	22,300	
PT-RC-86-131	Melones Fault	455	500	45	0.151	21,800	
PT-RC-86-131	Melones Fault	520	545	25	0.049	21,800	
PT-RC-86-132	Melones Fault	430	440	10	0.039	21,800	
PT-RC-86-132	Melones Fault	465	495	30	0.194	21,800	
PT-RC-86-132	Melones Fault	640	675	35	0.046	21,800	
QS-RC-86-133	Melones Queen Specimen	210	240	30	0.087	26,000	
QS-RC-86-133	Melones Queen Specimen	310	320	10	0.038	26,000	
QS-RC-86-133	Melones Queen Specimen	350	365	15	0.030	26,000	
QS-RC-86-134	Melones Queen Specimen	165	185	20	0.079	27,000	
QS-RC-86-135	Melones Queen Specimen	45	70	25	0.076	26,000	oxide
QS-RC-86-135	Melones Queen Specimen	105	120	15	0.037	26,000	
QS-RC-86-136	Melones Queen Specimen	185	205	20	0.103	26,200	
QS-RC-86-136	Melones Queen Specimen	290	315	25	0.123	26,200	
QS-RC-86-137	Melones Queen Specimen	230	250	20	0.048	25,800	
QS-RC-86-137	Melones Queen Specimen	290	325	35	0.038	25,800	
QS-RC-86-138	Melones Queen Specimen	370	390	20	0.083	26,000	
QS-RC-86-138	Melones Queen Specimen	455	465	10	0.040	26,000	

**TABLE APPEND I-1
SIGNIFICANT 1985-1986 DRILL HOLE INTERCEPTS ***

Drill Hole ID	Structure	From (ft)	To (ft)	Width (ft)	Au (oz/ton)	Section (North)	Oxide
QS-RC-86-139	Melones Queen Specimen	170	190	20	0.099	26,400	
QS-RC-86-139	Melones Queen Specimen	205	225	20	0.124	26,400	
QS-RC-86-140	Melones Queen Specimen						

Source: Burgoyne (2013)

APPENDIX J 2016-2017 SOIL GEOCHEMISTRY

Note: Au = gold, Ag = silver, As = arsenic, Ca = calcium, Cu = copper, Fe = iron, Mo = molybdenum, Pb = lead, S = sulphur, Sb = antimony, Zn = zinc.

TABLE APPENDIX J-1														
2016-2017 FREMONT SOIL GEOCHEMISTRY ASSAY RESULTS														
Sample ID	Easting	Northing	Year	Au (ppb)	Ag (ppb)	As (ppm)	Ca (ppm)	Cu (ppm)	Fe (ppm)	Mo (ppm)	Pb (ppm)	S (ppm)	Sb (ppm)	Zn (ppm)
209101	752,577	4,162,715	2016	13	-200	2	3180	72	33,700	-1	5	77	-3	44
209102	752,580	4,162,796	2016	6	-200	2	3330	63	31,010	-1	6	81	-3	47
209103	752,582	4,162,897	2016	6	-200	4	6310	68	35,500	-1	6	104	-3	44
209104	752,580	4,163,002	2016	30	-200	4	2140	49	32,600	-1	7	83	-3	25
209105	752,580	4,163,100	2016	4	-200	3	4080	65	45,400	-1	9	101	-3	47
209106	752,579	4,163,197	2016	10	-200	3	3960	74	44,300	-1	9	123	-3	47
209107	752,571	4,163,297	2016	6	200	6	7170	62	46,500	-1	10	275	-3	71
209108	752,576	4,163,403	2016	3	-200	3	3510	70	34,500	-1	7	93	-3	59
209109	752,577	4,163,501	2016	3	200	3	2980	89	43,900	-1	6	84	-3	51
209110	752,580	4,163,604	2016	6	-200	5	3050	90	54,200	-1	7	50	-3	46
209111	752,575	4,163,708	2016	6	-200	7	2940	92	57,500	-1	7	60	4	53
209112	752,581	4,163,798	2016	4	-200	7	2550	84	50,700	-1	5	51	-3	55
209113	752,577	4,163,854	2016	4	-200	7	3160	80	54,500	-1	8	91	-3	55
209114	752,582	4,164,005	2016	3	-200	13	3310	77	46,000	-1	9	74	-3	58
209115	752,574	4,164,097	2016	9	-200	18	2520	75	42,800	-1	7	54	-3	42
209117	752,581	4,164,203	2016	3	-200	15	4460	45	38,400	1	16	133	3	91
209118	752,584	4,164,299	2016	3	-200	10	1460	32	25,300	-1	21	60	-3	57

**TABLE APPENDIX J-1
2016-2017 FREMONT SOIL GEOCHEMISTRY ASSAY RESULTS**

Sample ID	Easting	Northing	Year	Au (ppb)	Ag (ppb)	As (ppm)	Ca (ppm)	Cu (ppm)	Fe (ppm)	Mo (ppm)	Pb (ppm)	S (ppm)	Sb (ppm)	Zn (ppm)
209119	752,584	4,164,399	2016	4	-200	14	2020	33	30,400	1	19	91	3	75
209120	752,580	4,164,505	2016	3	-200	13	1410	23	28,400	1	17	60	-3	65
209121	752,583	4,164,599	2016	3	-200	12	2880	32	29,800	1	22	153	-3	70
209122	752,577	4,164,704	2016	5	-200	27	2620	39	33,800	-1	21	91	4	91
209123	752,583	4,164,801	2016	5	-200	19	2440	45	32,100	-1	21	97	6	63
209124	752,582	4,164,904	2016	3	-200	10	2440	41	31,900	1	24	81	-3	85
209127	752,580	4,165,100	2016	4	-200	14	3830	28	29,300	1	23	155	-3	68
209128	752,572	4,165,212	2016	7	-200	20	3260	46	32,500	1	31	158	-3	95
209129	752,579	4,165,298	2016	3	-200	12	2270	47	32,100	1	24	126	3	92
209130	752,579	4,165,402	2016	3	-200	15	1440	42	32,400	1	16	54	3	56
209131	752,575	4,165,498	2016	4	-200	13	1920	33	29,600	-1	12	54	-3	48
209132	752,672	4,165,700	2016	8	-200	18	888	30	30,400	1	15	56	3	49
209133	752,685	4,165,805	2016	3	400	16	952	26	26,900	1	17	36	-3	40
209134	752,773	4,166,002	2016	-3	200	10	1770	21	24,700	-1	19	57	-3	44
209135	753,179	4,162,726	2016	4	200	5	5090	67	51,500	-1	7	118	-3	63
209136	752,680	4,165,896	2016	4	-200	11	1600	22	22,700	-1	24	61	-3	47
209137	752,680	4,165,996	2016	24	-200	9	3030	12	17,100	1	32	102	-3	37
209138	753,185	4,162,805	2016	6	200	6	5970	79	48,300	-1	8	196	-3	60
209139	752,681	4,166,107	2016	3	-200	12	2980	27	24,600	-1	21	145	-3	48
209140	753,175	4,162,901	2016	3	-200	5	4970	54	43,500	-1	8	154	-3	67
209141	753,180	4,162,998	2016	33	-200	77	1560	76	40,000	2	15	37	6	69
209142	753,183	4,163,088	2016	6	-200	14	6030	59	56,200	-1	9	119	4	87
209143	753,178	4,163,205	2016	-3	-200	9	1,160	33	29,310	-1	18	51	-3	77
209144	753,182	4,163,296	2016	15	-200	35	365	59	38,300	3	18	49	4	79
209145	753,176	4,163,497	2016	3	-200	9	843	29	27,000	1	14	84	-3	53
209146	753,177	4,163,497	2016	3	-200	12	394	33	33,200	2	17	50	-3	47
209147	753,175	4,163,597	2016	-3	-200	10	836	29	30,300	2	18	56	-3	64

**TABLE APPENDIX J-1
2016-2017 FREMONT SOIL GEOCHEMISTRY ASSAY RESULTS**

Sample ID	Easting	Northing	Year	Au (ppb)	Ag (ppb)	As (ppm)	Ca (ppm)	Cu (ppm)	Fe (ppm)	Mo (ppm)	Pb (ppm)	S (ppm)	Sb (ppm)	Zn (ppm)
209148	753,179	4,163,704	2016	4	-200	12	794	35	30,900	2	16	46	-3	62
209149	753,181	4,163,805	2016	6	-200	32	877	38	33,200	2	18	55	4	66
209150	753,187	4,163,903	2016	3	-200	10	1,360	31	28,900	1	19	57	-3	55
209151	753,181	4,163,998	2016	6	200	21	494	34	37,500	2	19	46	4	57
209152	753,184	4,164,103	2016	4	-200	18	1,490	23	35,000	2	18	108	4	72
209153	753,184	4,164,210	2016	8	-200	31	1,210	27	34,400	1	19	87	3	51
209154	753,183	4,164,301	2016	3	-200	28	3,120	27	34,800	1	19	177	4	56
209155	753,183	4,164,398	2016	3	-200	27	1,870	32	36,300	1	26	150	5	66
209156	753,178	4,164,496	2016	9	-200	14	2,610	34	28,200	1	24	100	3	71
209157	753,174	4,164,602	2016	3	-200	12	2,450	31	29,600	-1	15	95	-3	56
209158	753,178	4,164,702	2016	-3	-200	11	1,170	30	30,800	1	17	147	-3	57
209159	753,193	4,164,800	2016	14	-200	18	1,980	43	34,300	1	20	98	-3	65
209160	753,183	4,164,905	2016	14	-200	20	2,250	29	28,100	1	21	129	3	51
209161	753,168	4,165,005	2016	13	-200	22	2,650	43	32,400	1	19	30	-3	67
209162	753,184	4,165,146	2016	7	-200	13	1,240	36	25,900	-1	23	25	-3	63
209163	753,168	4,165,213	2016	8	-200	20	1,360	31	30,800	-1	23	23	-3	63
209164	753,170	4,165,307	2016	-3	-200	27	1,500	21	24,600	-1	20	60	-3	44
209165	753,186	4,165,415	2016	9	-200	22	2,060	32	31,600	-1	23	71	-3	69
209166	753,182	4,165,507	2016	3	-200	12	1,770	13	18,600	-1	25	89	-3	39
209167	753,182	4,165,602	2016	14	-200	39	1,770	32	28,100	-1	16	68	-3	48
209168	753,182	4,165,702	2016	23	-200	83	1,190	25	22,800	-1	22	44	-3	46
209169	753,183	4,165,801	2016	3	-200	24	1,230	11	15,200	-1	25	45	-3	32
209170	753,167	4,165,906	2016	40	-200	144	817	27	30,700	2	19	46	5	52
209171	753,179	4,165,997	2016	143	200	495	2,800	30	44,400	-1	13	88	9	50
209172	753,183	4,166,099	2016	95	400	202	2,500	40	47,900	2	13	113	8	86
209173	753,181	4,166,203	2016	118	400	238	1,530	38	55,900	2	13	99	7	210
209174	753,180	4,166,297	2016	30	-200	32	1,560	21	38,100	1	9	92	4	59

**TABLE APPENDIX J-1
2016-2017 FREMONT SOIL GEOCHEMISTRY ASSAY RESULTS**

Sample ID	Easting	Northing	Year	Au (ppb)	Ag (ppb)	As (ppm)	Ca (ppm)	Cu (ppm)	Fe (ppm)	Mo (ppm)	Pb (ppm)	S (ppm)	Sb (ppm)	Zn (ppm)
209177	753,179	4,166,481	2016	4	-200	2	1,780	15	44,100	-1	6	112	-3	25
209178	756,380	4,163,099	2016	5	-200	4	3,460	55	21,700	-1	11	204	-3	44
209179	756,278	4,163,102	2016	17	-200	2	3,690	56	21,600	-1	6	143	-3	32
209180	756,180	4,163,101	2016	6	-200	3	3,070	69	23,100	-1	5	99	-3	35
209181	756,078	4,163,103	2016	8	-200	3	2,930	65	27,600	-1	7	71	-3	28
209182	755,975	4,163,099	2016	4	-200	3	2,630	62	29,000	-1	7	117	-3	27
209183	755,874	4,163,107	2016	3	-200	2	3,740	62	22,900	-1	5	120	-3	31
209184	755,677	4,163,098	2016	5	-200	-2	3,690	55	20,300	-1	6	120	-3	26
209185	755,576	4,163,101	2016	4	-200	2	3,220	62	26,400	-1	6	89	-3	31
209186	755,478	4,163,092	2016	3	-200	3	2,650	55	25,000	-1	6	78	-3	33
209187	755,380	4,163,107	2016	18	-200	3	2,720	64	26,700	-1	7	79	-3	27
209188	755,280	4,163,098	2016	5	-200	3	3,100	65	26,600	-1	5	72	-3	26
209189	755,175	4,163,102	2016	5	-200	2	2,740	64	22,400	-1	6	130	-3	32
209190	755,081	4,163,103	2016	5	-200	3	2,810	57	23,400	-1	7	78	-3	30
209191	754,982	4,163,103	2016	5	-200	5	3,060	62	26,400	-1	6	70	-3	32
209192	754,876	4,163,098	2016	3	-200	3	1,920	49	26,400	-1	9	82	-3	26
209193	754,783	4,163,100	2016	5	-200	4	3,260	76	29,100	-1	6	95	-3	36
209194	754,680	4,163,099	2016	81	-200	187	2,640	61	33,000	-1	9	62	8	40
209195	754,578	4,163,101	2016	195	-200	255	3,150	43	43,000	1	10	77	5	35
209196	754,481	4,163,102	2016	44	-200	97	1,760	24	24,900	1	19	81	3	39
209197	754,375	4,163,100	2016	46	-200	58	2,350	38	28,700	1	234	115	9	40
209198	755,784	4,163,099	2016	5	-200	2	4,620	71	22,400	-1	7	64	-3	34
209199	753,677	4,162,798	2016	3	-200	9	2,320	30	30,600	1	17	81	-3	60
209200	753,678	4,162,899	2016	6	-200	10	1,240	34	33,000	1	16	68	-3	67
209201	752,481	4,162,713	2016	5	-200	-2	3,710	43	36,500	-1	5	50	-3	42
209202	752,483	4,162,796	2016	5	-200	2	2,510	76	40,300	-1	6	50	-3	34
209203	752,483	4,162,900	2016	3	-200	2	2,750	53	33,500	-1	5	61	-3	40

**TABLE APPENDIX J-1
2016-2017 FREMONT SOIL GEOCHEMISTRY ASSAY RESULTS**

Sample ID	Easting	Northing	Year	Au (ppb)	Ag (ppb)	As (ppm)	Ca (ppm)	Cu (ppm)	Fe (ppm)	Mo (ppm)	Pb (ppm)	S (ppm)	Sb (ppm)	Zn (ppm)
209204	752,481	4,162,995	2016	4	-200	-2	3,760	65	33,510	-1	4	56	-3	41
209205	752,477	4,163,099	2016	6	-200	-2	1,940	44	29,700	-1	4	40	-3	32
209206	752,480	4,163,198	2016	4	-200	2	3,090	45	30,500	-1	5	79	-3	39
209207	752,478	4,163,300	2016	3	-200	3	3,410	67	58,100	-1	7	77	-3	51
209208	752,478	4,163,399	2016	6	-200	3	5,070	74	41,400	-1	4	77	-3	51
209209	752,479	4,163,501	2016	-3	-200	5	2,270	64	38,500	-1	4	39	-3	45
209210	752,478	4,163,599	2016	3	-200	7	2,360	71	42,000	-1	6	45	-3	46
209211	752,481	4,163,699	2016	5	-200	5	3,160	87	58,000	-1	5	52	3	54
209212	752,477	4,163,801	2016	77	-200	6	5,490	92	58,700	-1	6	99	-3	58
209213	752,483	4,163,902	2016	5	-200	11	3,010	75	51,600	-1	6	70	-3	56
209214	752,483	4,163,998	2016	3	-200	15	2,170	75	53,200	-1	7	37	-3	44
209215	752,477	4,164,100	2016	3	-200	8	2,370	58	45,000	-1	9	42	-3	37
209216	752,485	4,164,197	2016	9	-200	13	6,490	73	46,700	2	8	218	-3	52
209217	752,479	4,164,300	2016	3	-200	11	2,000	38	32,500	-1	22	80	-3	82
209218	752,479	4,164,501	2016	5	-200	13	1,330	43	32,700	2	20	38	-3	80
209219	752,481	4,164,401	2016	3	-200	13	3,420	33	28,900	1	22	164	-3	68
209220	752,479	4,164,601	2016	3	-200	7	2,090	35	28,700	-1	18	89	-3	82
209221	752,476	4,164,697	2016	6	300	15	2,530	49	36,100	2	27	85	3	91
209222	752,480	4,164,800	2016	4	-200	28	1,590	35	31,400	1	18	60	3	59
209223	752,482	4,164,895	2016	9	-200	14	1,490	45	37,700	1	18	26	3	75
209224	752,478	4,165,002	2016	29	-200	16	2,810	26	33,500	-1	18	146	4	63
209227	752,478	4,165,202	2016	16	-200	19	1,060	34	32,900	1	25	73	3	74
209228	752,478	4,165,303	2016	3	-200	16	1,600	24	28,600	1	17	67	3	50
209229	752,479	4,165,398	2016	4	-200	19	1,400	43	38,600	2	25	58	5	74
209230	752,481	4,165,499	2016	3	-200	13	2,030	30	30,100	1	15	86	-3	61
209231	752,584	4,165,601	2016	-3	-200	10	1,380	18	28,700	1	12	50	-3	35
209232	752,582	4,165,697	2016	10	-200	10	974	19	29,000	-1	12	54	-3	43

**TABLE APPENDIX J-1
2016-2017 FREMONT SOIL GEOCHEMISTRY ASSAY RESULTS**

Sample ID	Easting	Northing	Year	Au (ppb)	Ag (ppb)	As (ppm)	Ca (ppm)	Cu (ppm)	Fe (ppm)	Mo (ppm)	Pb (ppm)	S (ppm)	Sb (ppm)	Zn (ppm)
209233	752,578	4,165,804	2016	17	-200	21	774	29	30,900	1	14	41	3	42
209234	752,583	4,165,901	2016	10	-200	32	1,030	23	30,000	1	15	26	-3	37
209235	752,578	4,165,996	2016	6	-200	16	1,580	19	26,100	1	23	98	-3	50
209236	752,577	4,166,100	2016	3	-200	7	1,610	21	25,410	-1	24	68	-3	37
209237	752,582	4,166,196	2016	3	-200	15	1,790	38	29,000	1	20	63	-3	54
209238	752,579	4,166,296	2016	-3	-200	12	1,090	33	30,700	1	17	46	-3	53
209239	753,282	4,162,728	2016	4	-200	14	3,120	39	36,910	1	18	95	-3	85
209240	753,279	4,162,801	2016	3	-200	16	3,100	51	41,100	1	12	64	-3	57
209241	753,277	4,162,903	2016	7	-200	8	3,630	49	47,700	1	8	42	3	60
209242	753,278	4,162,998	2016	11	-200	58	1,090	40	36,200	2	15	55	5	73
209243	753,278	4,163,101	2016	3	-200	12	1,830	34	30,500	1	18	57	-3	71
209244	753,282	4,163,201	2016	3	-200	15	999	31	28,300	1	14	41	3	57
209245	753,281	4,163,294	2016	3	-200	10	561	32	33,500	1	14	58	-3	55
209246	753,280	4,163,397	2016	3	-200	12	1,160	29	33,800	2	17	72	-3	65
209247	753,280	4,163,501	2016	-3	-200	11	2,700	28	32,500	1	17	86	-3	62
209248	753,277	4,163,597	2016	5	-200	12	342	35	35,200	2	15	47	3	61
209249	753,286	4,163,701	2016	3	-200	12	3,350	35	31,600	-1	18	125	-3	65
209250	753,279	4,163,797	2016	5	-200	21	1,380	25	38,500	2	15	62	3	78
209251	753,277	4,163,897	2016	4	-200	14	582	26	35,100	2	15	47	-3	67
209252	753,276	4,163,999	2016	6	-200	33	523	24	36,700	1	12	38	6	46
209253	753,276	4,164,097	2016	5	200	14	1,410	34	34,200	1	16	67	3	66
209254	753,277	4,164,201	2016	7	300	31	789	52	46,400	3	27	64	7	74
209255	753,278	4,164,300	2016	9	-200	27	1,830	37	33,000	1	20	79	5	79
209256	753,275	4,164,398	2016	-3	200	25	4,710	33	38,300	-1	14	213	4	69
209257	753,284	4,164,500	2016	5	-200	31	680	29	37,000	1	12	51	6	50
209258	753,279	4,164,595	2016	3	-200	10	5,290	27	30,100	1	15	237	-3	53
209259	753,281	4,164,699	2016	3	-200	8	3,220	21	31,400	-1	14	171	-3	55

**TABLE APPENDIX J-1
2016-2017 FREMONT SOIL GEOCHEMISTRY ASSAY RESULTS**

Sample ID	Easting	Northing	Year	Au (ppb)	Ag (ppb)	As (ppm)	Ca (ppm)	Cu (ppm)	Fe (ppm)	Mo (ppm)	Pb (ppm)	S (ppm)	Sb (ppm)	Zn (ppm)
209260	753,277	4,164,796	2016	-3	-200	11	1,410	14	18,700	1	30	81	-3	40
209261	753,280	4,164,903	2016	3	-200	10	2,130	22	25,600	-1	21	104	-3	53
209262	753,283	4,164,997	2016	3	-200	13	1,110	27	25,800	1	18	55	-3	49
209263	753,274	4,165,100	2016	4	-200	26	1,360	16	23,000	-1	18	52	-3	40
209264	753,277	4,165,198	2016	5	-200	12	1,070	20	27,200	-1	12	64	-3	43
209265	753,281	4,165,298	2016	3	-200	12	956	24	28,700	-1	13	48	-3	43
209266	753,283	4,165,397	2016	4	-200	17	1,170	22	27,200	-1	15	58	-3	40
209267	753,283	4,165,499	2016	7	-200	27	1,360	30	31,500	-1	14	38	-3	55
209268	753,280	4,165,597	2016	42	-200	90	1,790	33	25,400	1	23	48	4	57
209269	753,277	4,165,696	2016	26	-200	88	1,430	21	24,900	-1	22	56	4	44
209270	753,283	4,165,803	2016	427	300	900	640	34	46,100	2	26	138	8	50
209271	753,282	4,165,896	2016	659	300	599	938	36	32,300	2	17	99	7	38
209272	753,270	4,165,995	2016	920	200	92	15	46	36,000	3	13	32	5	48
209273	753,281	4,166,097	2016	97	300	83	1,640	24	30,000	3	12	143	4	30
209274	753,280	4,166,202	2016	3	200	4	665	23	41,800	-1	3	20	3	28
209277	753,278	4,166,401	2016	3	-200	8	2,140	45	33,700	4	12	53	-3	121
209278	753,279	4,166,499	2016	9	300	14	1,600	53	30,300	8	16	67	3	219
209279	756,379	4,162,900	2016	9	-200	3	4,330	58	28,000	-1	10	121	-3	38
209280	756,281	4,162,899	2016	-3	-200	3	2,380	66	29,600	-1	6	72	-3	30
209281	756,180	4,162,900	2016	5	200	3	2,950	70	25,900	-1	7	114	-3	32
209282	756,081	4,162,900	2016	4	-200	3	2,310	65	26,900	-1	8	91	-3	28
209283	755,979	4,162,899	2016	4	-200	3	3,660	58	23,900	-1	7	116	-3	32
209284	755,878	4,162,898	2016	4	-200	3	2,770	58	26,600	-1	5	74	-3	29
209285	755,782	4,162,901	2016	4	-200	4	4,590	78	26,700	-1	7	119	-3	42
209286	755,680	4,162,898	2016	5	-200	3	2,530	52	25,100	-1	6	78	-3	30
209287	755,578	4,162,898	2016	3	-200	3	3,980	56	22,810	-1	8	129	-3	32
209288	755,482	4,162,901	2016	4	-200	-2	2,430	73	23,400	-1	5	88	-3	26

**TABLE APPENDIX J-1
2016-2017 FREMONT SOIL GEOCHEMISTRY ASSAY RESULTS**

Sample ID	Easting	Northing	Year	Au (ppb)	Ag (ppb)	As (ppm)	Ca (ppm)	Cu (ppm)	Fe (ppm)	Mo (ppm)	Pb (ppm)	S (ppm)	Sb (ppm)	Zn (ppm)
209289	755,378	4,162,899	2016	4	-200	3	3,270	55	27,500	-1	8	101	-3	26
209290	755,281	4,162,900	2016	3	-200	2	3,400	68	26,400	-1	7	99	-3	37
209291	755,178	4,162,899	2016	15	-200	-2	2,750	51	20,600	-1	6	104	-3	33
209292	755,079	4,162,899	2016	-3	-200	2	2,470	64	22,100	-1	4	47	-3	32
209293	754,979	4,162,901	2016	4	-200	2	3,110	72	22,600	-1	3	65	-3	32
209294	754,879	4,162,900	2016	4	-200	2	2,300	65	21,900	-1	6	68	-3	27
209295	754,779	4,162,899	2016	13	-200	24	3,390	52	24,810	-1	9	77	-3	36
209296	754,685	4,162,903	2016	548	300	233	1,460	102	38,800	4	12	81	4	75
209297	754,586	4,162,898	2016	45	-200	46	1,570	48	29,600	-1	7	61	-3	25
209298	754,481	4,162,900	2016	4	-200	26	734	10	15,400	2	16	46	-3	15
209299	754,386	4,162,907	2016	5	-200	12	1,510	24	29,900	1	12	53	-3	45
209300	753,780	4,162,800	2016	5	-200	12	1,000	31	31,900	2	18	94	-3	55
209301	752,679	4,162,722	2016	5	-200	2	3,480	72	40,100	-1	5	59	-3	43
209302	752,678	4,162,800	2016	-3	-200	6	2,110	75	36,400	-1	4	35	-3	33
209303	752,682	4,162,900	2016	-3	-200	5	2,900	63	39,000	-1	8	113	-3	55
209304	752,681	4,163,003	2016	5	-200	-2	3,580	74	46,100	-1	4	58	-3	34
209305	752,677	4,163,097	2016	5	-200	6	4,500	78	45,800	-1	4	51	-3	43
209306	752,673	4,163,199	2016	11	-200	7	4,890	84	57,400	-1	5	52	-3	41
209307	752,677	4,163,300	2016	3	-200	5	3,830	74	52,200	-1	8	142	-3	56
209308	752,680	4,163,398	2016	5	-200	5	1,900	81	49,300	-1	6	48	-3	45
209309	752,681	4,163,500	2016	7	-200	6	3,050	99	56,600	-1	5	63	-3	63
209310	752,682	4,163,599	2016	5	-200	4	3,280	93	70,400	-1	7	53	-3	53
209311	752,684	4,163,695	2016	6	-200	9	6,320	72	56,100	-1	10	319	-3	54
209312	752,678	4,163,796	2016	9	-200	25	1,820	114	72,100	-1	8	39	4	23
209313	752,680	4,163,899	2016	7	-200	11	3,010	89	57,300	-1	8	48	3	49
209314	752,680	4,163,997	2016	7	-200	9	2,790	80	45,400	1	10	78	-3	63
209315	752,677	4,164,100	2016	6	-200	8	4,220	51	44,300	-1	8	96	-3	58

**TABLE APPENDIX J-1
2016-2017 FREMONT SOIL GEOCHEMISTRY ASSAY RESULTS**

Sample ID	Easting	Northing	Year	Au (ppb)	Ag (ppb)	As (ppm)	Ca (ppm)	Cu (ppm)	Fe (ppm)	Mo (ppm)	Pb (ppm)	S (ppm)	Sb (ppm)	Zn (ppm)
209316	752,679	4,164,201	2016	8	-200	20	1,740	44	32,600	1	24	115	3	88
209317	752,677	4,164,301	2016	-3	-200	11	1,140	34	31,900	1	22	99	3	84
209318	752,680	4,164,399	2016	3	-200	8	1,550	32	29,100	-1	18	48	-3	68
209319	752,680	4,164,499	2016	-3	-200	9	1,240	29	28,100	-1	17	47	-3	61
209320	752,681	4,164,598	2016	8	-200	45	1,060	34	33,600	1	19	34	3	52
209321	752,679	4,164,700	2016	-3	-200	15	2,040	37	31,600	1	20	89	4	70
209322	752,681	4,164,801	2016	5	-200	12	1,260	41	32,700	-1	26	53	-3	80
209323	752,679	4,164,897	2016	3	-200	17	1,220	24	30,700	1	15	61	4	51
209324	752,681	4,165,002	2016	3	-200	25	554	22	36,800	2	15	50	4	48
209327	752,676	4,165,201	2016	3	200	17	1,530	37	37,000	2	25	90	4	65
209328	752,673	4,165,302	2016	4	200	19	1,410	38	39,800	1	19	71	4	73
209329	752,680	4,165,403	2016	-3	-200	10	3,580	32	30,900	-1	17	159	-3	57
209330	752,677	4,165,498	2016	3	-200	13	2,180	25	26,300	-1	13	71	-3	42
209331	752,680	4,165,602	2016	-3	-200	12	1,870	23	27,600	-1	14	73	-3	46
209332	752,973	4,162,727	2016	8	-200	4	3,660	87	58,700	-1	12	123	-3	40
209333	752,978	4,162,802	2016	6	-200	3	2,900	69	50,400	-1	8	97	-3	44
209334	752,982	4,162,902	2016	4	-200	4	3,540	77	51,500	-1	5	80	-3	43
209335	752,983	4,162,998	2016	3	-200	5	3,770	74	51,300	-1	6	77	-3	44
209336	752,978	4,163,101	2016	15	-200	5	4,370	87	54,500	1	7	99	-3	56
209337	752,977	4,163,199	2016	6	-200	8	5,140	67	55,000	-1	7	117	-3	55
209338	752,976	4,163,304	2016	4	-200	10	5,640	49	46,900	-1	11	79	-3	81
209339	752,979	4,163,406	2016	6	-200	9	5,170	50	49,900	2	7	45	3	89
209340	752,981	4,163,499	2016	4	-200	16	1,640	40	29,600	-1	18	59	-3	68
209341	752,982	4,163,596	2016	7	300	14	1,960	27	30,300	-1	20	61	-3	84
209342	752,979	4,163,700	2016	6	200	8	1,510	36	29,300	1	17	65	-3	75
209343	752,984	4,163,800	2016	5	-200	7	2,010	31	32,400	1	19	128	-3	74
209344	752,980	4,163,900	2016	4	-200	9	1,730	30	30,500	-1	20	80	-3	76

**TABLE APPENDIX J-1
2016-2017 FREMONT SOIL GEOCHEMISTRY ASSAY RESULTS**

Sample ID	Easting	Northing	Year	Au (ppb)	Ag (ppb)	As (ppm)	Ca (ppm)	Cu (ppm)	Fe (ppm)	Mo (ppm)	Pb (ppm)	S (ppm)	Sb (ppm)	Zn (ppm)
209345	752,980	4,163,997	2016	5	-200	21	2,800	35	32,000	-1	19	86	4	70
209346	752,979	4,164,101	2016	6	-200	12	5,140	34	30,200	-1	21	196	-3	82
209347	752,975	4,164,200	2016	7	-200	24	2,120	39	34,200	1	19	60	4	61
209348	752,981	4,164,300	2016	7	-200	29	3,130	36	34,300	1	19	209	6	75
209349	752,978	4,164,402	2016	4	200	12	1,430	32	34,700	1	23	93	-3	79
209350	752,979	4,164,497	2016	8	300	17	1,540	44	33,100	2	29	176	-3	86
209351	752,980	4,164,600	2016	6	-200	22	3,450	39	39,500	2	21	270	4	85
209352	752,982	4,164,700	2016	6	-200	23	1,410	34	33,400	1	19	62	5	71
209353	752,979	4,164,799	2016	4	-200	17	87	26	37,900	2	19	31	4	37
209354	752,982	4,164,899	2016	6	-200	14	522	25	30,700	2	18	29	-3	36
209355	752,979	4,164,999	2016	5	-200	16	732	35	31,600	1	20	35	-3	49
209356	752,979	4,165,104	2016	7	-200	14	2,990	33	28,500	-1	23	133	-3	66
209357	752,978	4,165,199	2016	6	-200	18	1,950	33	32,800	1	19	92	-3	47
209358	752,977	4,165,304	2016	8	-200	15	1,630	33	34,400	-1	15	55	4	54
209359	752,982	4,165,410	2016	6	-200	11	2,080	30	33,100	-1	15	83	-3	56
209360	752,981	4,165,501	2016	6	-200	16	1,490	9	11,900	-1	25	76	-3	27
209361	752,981	4,165,598	2016	5	-200	7	1,160	8	12,400	-1	27	80	-3	30
209362	752,980	4,165,702	2016	5	-200	13	2,230	30	29,100	-1	21	90	-3	60
209363	752,979	4,165,805	2016	6	-200	24	1,600	27	28,200	-1	21	56	4	56
209364	752,996	4,165,915	2016	6	-200	20	1,410	14	16,300	-1	24	66	-3	36
209365	752,977	4,165,998	2016	7	-200	26	1,530	17	17,600	1	22	62	-3	41
209366	752,981	4,166,100	2016	11	-200	38	1,260	25	29,500	-1	14	43	4	48
209367	752,979	4,166,198	2016	7	-200	27	2,370	24	23,800	1	31	128	4	56
209368	752,985	4,166,307	2016	11	200	69	1,340	56	35,600	2	17	81	-3	78
209369	753,382	4,162,739	2016	7	-200	11	3,230	45	37,000	2	20	121	-3	94
209370	753,385	4,162,803	2016	4	-200	16	1,260	33	32,800	1	15	61	4	67
209371	753,379	4,162,899	2016	3	-200	20	229	30	35,810	2	13	45	4	60

**TABLE APPENDIX J-1
2016-2017 FREMONT SOIL GEOCHEMISTRY ASSAY RESULTS**

Sample ID	Easting	Northing	Year	Au (ppb)	Ag (ppb)	As (ppm)	Ca (ppm)	Cu (ppm)	Fe (ppm)	Mo (ppm)	Pb (ppm)	S (ppm)	Sb (ppm)	Zn (ppm)
209372	753,380	4,163,000	2016	4	-200	11	1,270	31	35,200	1	15	65	-3	81
209373	753,381	4,163,101	2016	4	-200	12	611	31	36,500	2	16	45	-3	65
209374	753,381	4,163,199	2016	5	-200	10	1,650	30	33,900	1	16	62	-3	70
209377	753,383	4,163,399	2016	6	-200	11	658	26	33,100	1	13	50	-3	53
209378	753,383	4,163,499	2016	4	-200	15	3,300	39	35,310	-1	18	140	-3	77
209379	753,376	4,163,600	2016	6	-200	12	1,800	39	36,400	-1	20	90	3	84
209380	753,380	4,163,699	2016	5	-200	13	1,480	29	32,900	2	17	72	-3	64
209381	753,380	4,163,801	2016	10	-200	18	480	25	32,410	1	13	31	-3	40
209382	753,383	4,163,903	2016	6	-200	17	1,830	30	33,700	1	16	78	3	58
209383	753,382	4,164,000	2016	6	-200	23	1,270	25	31,300	2	23	68	4	51
209384	753,380	4,164,098	2016	7	-200	22	1,300	33	33,700	1	19	42	-3	46
209385	753,378	4,164,198	2016	7	-200	23	1,340	30	36,300	1	14	94	5	81
209386	753,379	4,164,297	2016	6	-200	21	1,570	45	39,910	2	16	64	4	69
209387	753,379	4,164,398	2016	5	-200	20	1,520	26	37,500	1	16	70	4	49
209388	753,382	4,164,500	2016	4	-200	15	2,950	23	35,900	-1	15	160	3	57
209389	753,382	4,164,599	2016	9	-200	12	2,110	24	35,100	1	15	119	-3	55
209390	753,377	4,164,697	2016	9	-200	23	2,930	31	27,300	-1	19	109	-3	53
209391	756,380	4,163,000	2016	9	-200	4	5,120	71	31,500	-1	8	166	-3	38
209392	756,280	4,163,000	2016	9	-200	4	2,620	89	32,800	-1	5	69	-3	29
209393	756,180	4,163,001	2016	6	-200	4	2,680	77	26,900	-1	4	74	-3	34
209394	756,079	4,163,000	2016	7	-200	3	2,590	62	26,600	-1	5	78	-3	30
209395	755,980	4,163,000	2016	7	-200	4	2,580	60	29,300	-1	5	84	-3	32
209396	755,880	4,162,999	2016	8	-200	4	2,770	49	29,800	-1	8	125	-3	32
209397	755,781	4,163,000	2016	7	-200	3	3,170	59	28,100	-1	6	115	-3	34
209398	755,680	4,162,998	2016	9	-200	3	3,680	58	22,700	-1	5	127	-3	28
209399	755,578	4,162,998	2016	12	-200	2	4,460	126	21,100	-1	3	77	-3	40
209400	755,480	4,162,996	2016	6	-200	3	3,180	59	28,900	-1	8	137	-3	34

**TABLE APPENDIX J-1
2016-2017 FREMONT SOIL GEOCHEMISTRY ASSAY RESULTS**

Sample ID	Easting	Northing	Year	Au (ppb)	Ag (ppb)	As (ppm)	Ca (ppm)	Cu (ppm)	Fe (ppm)	Mo (ppm)	Pb (ppm)	S (ppm)	Sb (ppm)	Zn (ppm)
209401	752,382	4,162,711	2016	7	-200	-2	3,710	32	28,600	-1	13	102	-3	37
209402	752,385	4,162,800	2016	11	-200	2	3,820	36	31,700	-1	5	95	-3	38
209403	752,385	4,162,899	2016	4	-200	2	3,210	65	43,000	-1	7	76	-3	39
209404	752,381	4,163,002	2016	8	-200	3	2,780	60	38,300	-1	7	59	-3	35
209405	752,380	4,163,096	2016	6	-200	2	7,020	57	34,700	-1	6	84	-3	35
209406	752,380	4,163,201	2016	5	-200	3	2,800	55	35,600	-1	7	88	-3	40
209407	752,381	4,163,294	2016	7	-200	3	2,800	50	34,100	-1	6	84	-3	34
209408	752,379	4,163,399	2016	5	-200	12	2,540	61	43,700	-1	618	51	14	30
209409	752,379	4,163,500	2016	6	-200	2	4,180	60	39,600	-1	11	102	-3	54
209410	752,382	4,163,605	2016	5	-200	5	3,000	66	42,400	-1	6	68	-3	56
209411	752,386	4,163,704	2016	6	-200	3	3,160	96	56,400	-1	6	72	-3	46
209412	752,378	4,163,801	2016	6	-200	2	3,680	89	51,100	-1	6	76	-3	51
209413	752,382	4,163,898	2016	9	-200	8	3,470	97	57,300	-1	4	27	-3	46
209414	752,375	4,164,002	2016	5	-200	6	4,030	84	57,400	-1	7	75	-3	54
209415	752,386	4,164,102	2016	6	-200	5	2,290	78	55,000	-1	9	46	-3	50
209416	752,381	4,164,194	2016	7	-200	8	1,990	69	52,900	1	13	34	-3	31
209417	752,382	4,164,302	2016	8	-200	22	623	45	37,300	2	15	54	4	63
209418	752,383	4,164,403	2016	7	200	12	2,280	40	31,500	1	22	92	-3	94
209419	752,382	4,164,503	2016	4	-200	11	2,210	34	31,100	1	18	112	-3	66
209420	752,385	4,164,602	2016	3	-200	9	1,490	32	29,500	-1	19	92	-3	70
209421	752,380	4,164,701	2016	6	-200	15	1,290	30	29,300	1	17	54	-3	68
209422	752,378	4,164,804	2016	6	-200	25	1,540	43	35,100	2	20	48	4	75
209423	752,383	4,164,902	2016	5	-200	17	2,370	34	33,400	1	21	80	3	78
209424	752,376	4,165,005	2016	4	-200	14	2,610	27	31,700	-1	19	115	-3	60
209427	752,377	4,165,205	2016	7	-200	10	2,960	40	28,100	1	23	148	-3	71
209428	752,379	4,165,297	2016	4	-200	15	1,260	23	27,500	1	14	61	3	45
209429	752,382	4,165,399	2016	4	-200	10	2,680	38	32,800	1	20	93	-3	72

**TABLE APPENDIX J-1
2016-2017 FREMONT SOIL GEOCHEMISTRY ASSAY RESULTS**

Sample ID	Easting	Northing	Year	Au (ppb)	Ag (ppb)	As (ppm)	Ca (ppm)	Cu (ppm)	Fe (ppm)	Mo (ppm)	Pb (ppm)	S (ppm)	Sb (ppm)	Zn (ppm)
209430	752,384	4,165,498	2016	7	-200	21	3,130	35	33,200	2	28	126	5	79
209431	752,382	4,166,400	2016	4	-200	7	2,280	13	18,200	-1	19	90	-3	31
209432	752,374	4,166,302	2016	5	-200	8	2,970	18	22,900	-1	22	118	-3	40
209433	752,375	4,166,196	2016	4	-200	9	789	9	18,500	1	25	41	-3	22
209434	752,379	4,166,095	2016	3	-200	7	1,460	7	21,600	1	17	67	-3	34
209435	752,379	4,166,003	2016	7	-200	15	2,070	31	24,300	1	22	72	-3	52
209436	752,389	4,165,904	2016	4	-200	10	4,580	22	31,500	-1	15	185	-3	49
209437	752,489	4,165,809	2016	3	-200	8	2,960	18	29,900	1	11	96	-3	58
209438	752,477	4,165,897	2016	4	-200	13	3,140	30	31,900	-1	16	124	-3	53
209439	752,474	4,166,004	2016	3	-200	8	1,100	9	12,900	1	24	33	-3	29
209440	752,487	4,166,096	2016	5	-200	10	1,530	25	26,200	-1	13	55	-3	34
209441	752,468	4,166,205	2016	6	-200	12	1,580	22	30,000	-1	17	82	-3	46
209442	752,485	4,166,295	2016	4	-200	13	1,470	40	31,500	1	23	108	-3	67
209443	752,480	4,166,387	2016	5	-200	10	2,460	31	32,500	-1	18	119	-3	60
209444	753,080	4,162,730	2016	5	-200	4	3,780	69	47,900	-1	8	93	-3	43
209445	753,079	4,162,796	2016	6	-200	7	4,690	77	54,300	-1	7	111	-3	45
209446	753,079	4,162,899	2016	3	-200	7	3,650	61	49,200	-1	9	174	-3	47
209447	753,077	4,162,995	2016	4	-200	15	5,460	66	54,500	-1	7	77	4	58
209448	753,085	4,163,098	2016	3	-200	6	3,870	66	56,900	-1	9	78	-3	63
209449	753,074	4,163,197	2016	5	-200	16	2,870	39	43,300	1	10	85	-3	76
209450	753,079	4,163,295	2016	9	-200	12	4,650	51	47,500	1	11	67	-3	80
209451	753,076	4,163,399	2016	6	-200	12	4,160	48	38,500	1	15	100	-3	86
209452	753,078	4,163,502	2016	4	-200	7	2,200	27	30,100	1	17	103	-3	94
209453	753,076	4,163,601	2016	5	-200	8	1,810	31	29,800	1	17	75	-3	69
209454	753,078	4,163,703	2016	6	-200	9	2,810	31	31,800	1	17	90	-3	90
209455	753,082	4,163,796	2016	3	-200	11	1,340	27	30,500	1	16	56	-3	59
209456	753,073	4,163,896	2016	5	-200	13	1,980	38	31,200	1	20	75	-3	74

**TABLE APPENDIX J-1
2016-2017 FREMONT SOIL GEOCHEMISTRY ASSAY RESULTS**

Sample ID	Easting	Northing	Year	Au (ppb)	Ag (ppb)	As (ppm)	Ca (ppm)	Cu (ppm)	Fe (ppm)	Mo (ppm)	Pb (ppm)	S (ppm)	Sb (ppm)	Zn (ppm)
209457	753,077	4,163,998	2016	10	-200	15	2,810	31	28,700	1	21	126	-3	67
209458	753,081	4,164,097	2016	19	-200	28	4,050	46	33,300	1	24	250	3	78
209459	753,084	4,164,203	2016	9	200	17	2,780	39	35,600	1	26	118	-3	95
209460	753,076	4,164,301	2016	6	-200	17	1,670	35	36,100	1	20	70	-3	63
209461	753,083	4,164,402	2016	5	-200	11	3,770	31	34,500	1	21	146	-3	79
209462	753,083	4,164,495	2016	6	-200	21	2,290	22	38,700	1	19	83	4	75
209463	753,084	4,164,601	2016	7	-200	35	3,990	28	40,000	1	19	145	5	64
209464	753,082	4,164,706	2016	4	-200	8	3,530	26	27,900	-1	20	160	-3	44
209465	753,083	4,164,800	2016	3	-200	14	2,050	27	27,000	-1	22	86	-3	46
209466	753,080	4,164,896	2016	4	-200	12	2,080	27	30,000	1	20	67	-3	52
209467	753,081	4,164,994	2016	5	-200	13	1,530	31	31,300	-1	16	65	3	48
209468	753,089	4,165,097	2016	7	-200	16	4,920	40	32,400	1	22	172	-3	63
209469	753,082	4,165,203	2016	26	-200	24	1,140	32	34,300	1	18	67	3	52
209470	753,077	4,165,297	2016	5	-200	11	1,470	22	25,800	-1	20	67	-3	49
209471	753,077	4,165,399	2016	8	-200	37	2,730	24	27,100	-1	24	120	-3	42
209472	753,082	4,165,497	2016	10	-200	17	1,240	30	30,000	1	20	65	-3	56
209473	753,096	4,165,604	2016	29	-200	45	1,290	33	27,800	-1	23	48	-3	60
209474	753,079	4,165,701	2016	24	-200	27	10,810	54	31,200	2	21	49	4	83
209477	753,077	4,165,899	2016	10	-200	65	1,230	21	22,200	1	24	54	-3	40
209478	753,074	4,166,003	2016	5	-200	25	2,410	11	11,400	1	36	132	-3	47
209479	753,072	4,166,105	2016	20	-200	66	2,430	23	29,810	1	17	100	5	53
209480	753,071	4,166,202	2016	10	-200	42	1,250	15	20,100	1	22	95	-3	97
209481	753,074	4,166,303	2016	1,430	400	87	4,170	32	39,200	-1	17	272	-3	72
209482	753,078	4,166,404	2016	14	-200	3	826	22	67,000	-1	7	93	5	19
209483	753,079	4,166,474	2016	12	-200	3	786	18	57,900	-1	8	81	-3	29
209484	756,379	4,163,200	2016	8	-200	3	2,930	63	19,300	-1	6	108	-3	26
209485	756,280	4,163,200	2016	8	-200	2	2,870	60	25,700	-1	9	92	-3	32

**TABLE APPENDIX J-1
2016-2017 FREMONT SOIL GEOCHEMISTRY ASSAY RESULTS**

Sample ID	Easting	Northing	Year	Au (ppb)	Ag (ppb)	As (ppm)	Ca (ppm)	Cu (ppm)	Fe (ppm)	Mo (ppm)	Pb (ppm)	S (ppm)	Sb (ppm)	Zn (ppm)
209486	756,180	4,163,199	2016	13	-200	2	2,800	75	22,800	-1	6	117	-3	30
209487	756,078	4,163,198	2016	7	-200	3	2,820	61	24,300	-1	7	94	-3	27
209488	755,978	4,163,198	2016	24	-200	5	2,580	59	24,900	-1	7	109	-3	28
209489	755,880	4,163,200	2016	21	-200	6	4,840	93	29,500	-1	4	51	-3	50
209490	755,780	4,163,200	2016	6	-200	3	3,610	67	23,300	-1	5	86	-3	33
209491	755,682	4,163,200	2016	6	-200	2	3,540	45	18,400	-1	3	55	-3	30
209492	755,582	4,163,199	2016	6	-200	2	2,700	53	21,500	-1	8	86	-3	30
209493	755,479	4,163,199	2016	6	-200	3	3,220	56	27,000	-1	11	163	-3	30
209494	755,379	4,163,201	2016	10	-200	3	3,270	68	28,200	-1	7	100	-3	30
209495	755,279	4,163,199	2016	9	-200	3	3,630	61	30,700	-1	8	180	-3	30
209496	755,180	4,163,199	2016	8	-200	4	3,080	55	19,800	-1	5	184	-3	32
209497	755,080	4,163,201	2016	6	-200	-2	2,660	50	18,300	-1	4	60	-3	28
209498	754,980	4,163,200	2016	5	-200	-2	3,990	56	22,500	-1	6	141	-3	32
209499	754,881	4,163,201	2016	5	-200	3	3,480	56	26,900	-1	7	100	-3	25
209500	754,779	4,163,200	2016	7	-200	10	2,580	59	27,900	-1	8	102	-3	35
209501	752,780	4,162,728	2016	6	-200	3	4,220	104	49,200	-1	5	90	-3	62
209502	752,779	4,162,799	2016	6	-200	5	5,100	77	52,300	-1	6	66	-3	58
209503	752,781	4,162,905	2016	10	-200	10	6,920	91	40,900	-1	5	44	-3	61
209504	752,778	4,162,997	2016	7	-200	5	4,890	84	51,200	-1	4	42	-3	43
209505	752,781	4,163,097	2016	6	-200	15	4,440	78	54,900	-1	4	49	3	50
209506	752,782	4,163,202	2016	5	-200	7	4,150	68	53,900	-1	6	60	-3	53
209507	752,785	4,163,300	2016	8	-200	8	2,770	88	57,300	-1	6	44	-3	45
209508	752,771	4,163,406	2016	6	-200	13	5,850	114	62,800	-1	6	72	3	66
209509	752,785	4,163,502	2016	12	-200	11	6,370	110	62,910	-1	5	80	-3	72
209510	752,776	4,163,596	2016	5	-200	10	2,950	90	56,300	-1	7	68	-3	51
209511	752,777	4,163,692	2016	11	-200	32	3,660	83	49,700	2	11	107	-3	62
209512	752,792	4,163,797	2016	3	-200	13	2,860	29	33,900	-1	14	97	-3	77

**TABLE APPENDIX J-1
2016-2017 FREMONT SOIL GEOCHEMISTRY ASSAY RESULTS**

Sample ID	Easting	Northing	Year	Au (ppb)	Ag (ppb)	As (ppm)	Ca (ppm)	Cu (ppm)	Fe (ppm)	Mo (ppm)	Pb (ppm)	S (ppm)	Sb (ppm)	Zn (ppm)
209513	752,777	4,163,901	2016	6	-200	11	2,920	36	39,500	-1	13	100	-3	65
209514	752,784	4,164,000	2016	4	-200	7	3,400	41	45,400	1	7	99	-3	63
209515	752,778	4,164,101	2016	5	-200	15	1,620	31	33,700	-1	17	48	3	74
209516	752,777	4,164,197	2016	6	-200	15	1,750	39	36,100	-1	18	67	3	68
209517	752,781	4,164,302	2016	10	-200	48	4,550	34	42,800	1	19	221	5	82
209518	752,781	4,164,397	2016	8	-200	32	2,120	41	34,500	-1	22	93	4	78
209519	752,775	4,164,500	2016	7	-200	27	2,270	39	33,100	1	22	150	-3	89
209520	752,778	4,164,600	2016	8	300	18	2,890	55	35,710	1	22	112	5	92
209521	752,783	4,164,699	2016	7	-200	25	1,480	43	34,500	1	25	73	4	67
209522	752,784	4,164,797	2016	9	-200	30	1,650	22	28,400	1	16	64	-3	45
209523	752,787	4,164,898	2016	5	-200	26	1,180	20	32,400	2	19	64	3	47
209524	752,785	4,165,002	2016	3	-200	15	1,140	32	34,000	1	19	65	-3	48
209527	752,782	4,165,193	2016	5	-200	15	575	27	34,100	2	23	37	-3	30
209528	752,780	4,165,299	2016	6	-200	21	1,110	29	34,900	1	18	61	4	45
209529	752,774	4,165,400	2016	5	-200	13	1,390	30	34,800	-1	17	73	-3	65
209530	752,781	4,165,498	2016	3	-200	12	1,780	28	29,400	-1	17	59	-3	53
209531	752,787	4,165,597	2016	7	-200	14	1,640	38	27,100	1	22	54	-3	61
209532	752,879	4,162,725	2016	5	-200	3	2,160	59	34,300	-1	8	63	-3	43
209533	752,879	4,162,800	2016	5	-200	4	1,830	44	38,700	-1	15	133	-3	36
209534	752,879	4,162,897	2016	9	-200	3	4,730	77	46,400	-1	9	140	-3	54
209535	752,853	4,163,005	2016	7	-200	7	3,930	84	56,500	-1	10	96	-3	43
209536	752,857	4,163,104	2016	5	-200	11	4,580	77	52,900	-1	8	110	-3	51
209537	752,872	4,163,205	2016	6	-200	16	4,120	86	50,800	-1	6	49	-3	54
209538	752,884	4,163,306	2016	6	-200	18	2,850	88	51,400	-1	5	56	-3	53
209539	752,880	4,163,399	2016	7	-200	9	3,290	67	46,500	-1	7	119	-3	68
209540	752,876	4,163,505	2016	6	-200	59	4,450	40	50,700	-1	8	84	4	89
209541	752,879	4,163,603	2016	7	-200	57	2,790	39	46,800	-1	10	57	3	88

**TABLE APPENDIX J-1
2016-2017 FREMONT SOIL GEOCHEMISTRY ASSAY RESULTS**

Sample ID	Easting	Northing	Year	Au (ppb)	Ag (ppb)	As (ppm)	Ca (ppm)	Cu (ppm)	Fe (ppm)	Mo (ppm)	Pb (ppm)	S (ppm)	Sb (ppm)	Zn (ppm)
209542	752,885	4,163,698	2016	6	-200	13	2,480	43	39,800	-1	16	67	-3	92
209543	752,874	4,163,801	2016	5	-200	11	1,380	33	31,000	1	18	51	-3	76
209544	752,873	4,163,898	2016	5	-200	17	2,410	29	33,600	-1	18	93	4	81
209545	752,879	4,163,998	2016	10	-200	29	1,350	38	38,600	1	20	63	6	80
209546	752,880	4,164,099	2016	7	200	39	1,700	38	38,100	2	21	73	5	77
209547	752,871	4,164,197	2016	4	-200	26	4,860	28	34,800	1	25	129	3	79
209548	752,883	4,164,298	2016	6	-200	34	1,570	39	36,500	1	21	63	5	83
209549	752,875	4,164,397	2016	6	-200	40	1,590	34	37,400	-1	20	71	6	86
209550	752,882	4,164,500	2016	5	-200	30	1,410	40	36,900	1	22	110	5	83
209551	752,882	4,164,605	2016	14	-200	26	1,150	54	38,600	2	29	101	5	89
209552	752,881	4,164,708	2016	4	-200	14	1,830	24	28,600	-1	16	80	3	65
209553	752,870	4,164,805	2016	5	-200	22	869	32	36,000	2	17	60	-3	48
209554	752,878	4,164,896	2016	5	-200	14	1,040	25	31,400	1	20	66	-3	56
209555	752,879	4,164,996	2016	7	-200	13	3,050	32	33,300	-1	28	153	-3	83
209556	752,875	4,165,103	2016	4	-200	19	1,500	30	30,900	1	21	48	-3	50
209557	752,872	4,165,201	2016	9	-200	35	578	39	33,700	2	21	39	4	50
209558	752,880	4,165,304	2016	6	-200	17	1,660	26	32,100	-1	16	58	-3	44
209559	752,886	4,165,403	2016	4	-200	11	1,230	21	29,300	-1	12	56	-3	40
209560	752,888	4,165,499	2016	5	-200	9	1,230	32	31,800	-1	13	43	-3	51
209561	752,880	4,165,603	2016	8	-200	16	1,580	12	11,910	-1	34	51	-3	30
209562	752,780	4,165,694	2016	4	-200	12	952	23	26,110	-1	19	46	-3	40
209563	752,791	4,165,797	2016	9	-200	14	1,250	22	25,100	1	30	56	-3	37
209564	752,778	4,165,893	2016	5	-200	11	1,460	15	20,200	1	27	69	-3	42
209565	752,881	4,165,799	2016	9	-200	14	1,150	24	23,300	-1	20	49	-3	40
209566	752,879	4,165,703	2016	5	-200	11	1,580	18	19,000	-1	21	64	-3	40
209567	753,479	4,162,735	2016	6	-200	28	878	35	30,100	2	15	63	4	60
209568	753,481	4,162,797	2016	5	-200	11	1,020	28	27,100	1	17	79	-3	51

**TABLE APPENDIX J-1
2016-2017 FREMONT SOIL GEOCHEMISTRY ASSAY RESULTS**

Sample ID	Easting	Northing	Year	Au (ppb)	Ag (ppb)	As (ppm)	Ca (ppm)	Cu (ppm)	Fe (ppm)	Mo (ppm)	Pb (ppm)	S (ppm)	Sb (ppm)	Zn (ppm)
209569	753,477	4,162,904	2016	6	-200	9	683	25	27,200	1	13	54	-3	38
209570	753,478	4,163,005	2016	4	-200	19	1,290	30	34,800	1	15	44	-3	62
209571	753,476	4,163,099	2016	4	-200	10	1,610	28	30,200	1	18	49	-3	68
209572	753,472	4,163,197	2016	5	-200	9	480	30	28,800	1	16	37	-3	56
209573	753,471	4,163,297	2016	5	-200	13	1,660	32	31,700	1	18	55	-3	63
209574	753,478	4,163,403	2016	6	-200	12	1,330	39	32,700	-1	21	66	-3	84
209577	753,480	4,163,598	2016	5	-200	11	1,330	20	27,900	1	15	81	-3	48
209578	753,500	4,163,673	2016	4	-200	15	1,450	25	25,600	-1	16	80	-3	40
209579	753,481	4,163,798	2016	5	-200	11	1,950	31	28,900	1	18	81	-3	57
209580	753,482	4,163,896	2016	6	-200	12	4,110	38	29,400	-1	22	143	-3	72
209581	753,480	4,164,005	2016	9	-200	25	1,750	45	35,500	1	37	59	4	71
209582	753,482	4,164,109	2016	-3	-200	9	2,100	25	29,900	-1	15	109	-3	52
209583	753,476	4,164,199	2016	-3	-200	11	2,080	25	30,800	-1	14	68	-3	46
209584	753,477	4,164,292	2016	-3	-200	12	1,660	23	29,100	1	16	83	-3	35
209585	753,478	4,164,394	2016	-3	-200	9	2,450	22	32,400	-1	15	100	-3	51
209586	753,482	4,164,497	2016	3	-200	13	1,400	22	28,410	-1	18	66	-3	51
209587	753,482	4,164,600	2016	12	-200	26	1,620	46	32,300	1	22	29	4	76
209588	753,489	4,164,699	2016	36	-200	26	1,470	29	26,000	-1	19	63	-3	50
209589	753,481	4,164,807	2016	30	-200	46	1,640	38	32,500	-1	15	40	3	66
209590	753,471	4,164,902	2016	13	-200	37	1,630	59	39,000	1	18	31	4	92
209591	756,378	4,162,826	2016	5	-200	3	2,480	60	25,600	-1	9	93	-3	26
209592	756,274	4,162,828	2016	4	-200	3	3,660	55	27,100	-1	9	142	-3	32
209593	756,176	4,162,829	2016	5	-200	3	2,660	62	25,900	-1	7	95	-3	31
209594	756,077	4,162,829	2016	3	-200	3	2,030	49	27,000	-1	7	62	-3	28
209595	755,974	4,162,828	2016	-3	-200	3	3,670	65	27,100	-1	7	100	-3	32
209596	755,879	4,162,823	2016	-3	-200	2	3,950	59	23,300	-1	7	109	-3	30
209597	755,780	4,162,823	2016	4	-200	3	2,480	54	27,100	-1	8	80	-3	28

**TABLE APPENDIX J-1
2016-2017 FREMONT SOIL GEOCHEMISTRY ASSAY RESULTS**

Sample ID	Easting	Northing	Year	Au (ppb)	Ag (ppb)	As (ppm)	Ca (ppm)	Cu (ppm)	Fe (ppm)	Mo (ppm)	Pb (ppm)	S (ppm)	Sb (ppm)	Zn (ppm)
209598	755,682	4,162,799	2016	3	-200	2	5,170	93	26,000	-1	4	42	-3	44
209599	755,574	4,162,802	2016	6	-200	4	2,860	55	30,100	-1	13	113	-3	28
209600	755,477	4,162,801	2016	4	-200	3	2,620	68	25,900	-1	8	85	-3	40
209601	755,376	4,162,800	2016	7	-200	3	3,100	48	21,900	-1	10	125	-3	40
209602	755,275	4,162,798	2016	-3	-200	2	2,290	62	23,600	-1	7	79	-3	31
209603	755,177	4,162,801	2016	-3	-200	2	1,750	56	28,400	-1	7	73	-3	30
209604	755,076	4,162,801	2016	4	-200	2	1,860	53	29,400	-1	8	70	-3	27
209605	754,979	4,162,804	2016	3	-200	2	2,240	55	27,900	-1	11	84	-3	33
209606	754,880	4,162,800	2016	-3	-200	2	3,730	67	22,100	-1	7	102	-3	33
209607	754,776	4,162,798	2016	22	-200	9	3,320	51	20,700	-1	7	102	-3	32
209608	754,676	4,162,801	2016	74	-200	62	1,740	56	36,600	1	9	85	-3	47
209609	754,578	4,162,802	2016	37	-200	44	1,400	37	32,800	1	14	76	-3	63
209610	754,481	4,162,806	2016	12	-200	25	1,470	28	25,000	1	17	75	-3	46
209611	754,396	4,162,798	2016	5	-200	12	1,140	27	28,100	1	14	57	-3	45
209612	753,478	4,164,999	2016	5	-200	53	1,310	26	27,300	-1	17	86	-3	53
209613	753,492	4,165,093	2016	-3	-200	17	1,430	25	22,800	1	20	67	-3	44
209614	753,485	4,165,210	2016	15	-200	26	1,680	13	18,800	1	20	76	-3	33
209615	753,477	4,165,314	2016	138	-200	113	1,510	38	49,000	1	11	44	7	34
209616	753,477	4,165,399	2016	302	-200	148	3,610	49	33,400	-1	15	33	8	48
209617	753,497	4,165,500	2016	103	500	438	2,240	73	34,800	-1	6	64	17	25
209618	753,472	4,165,600	2016	2,650	6300	2730	1,740	95	56,400	1	13	99	49	52
209619	753,479	4,165,693	2016	1,450	1500	1560	1,780	86	47,000	2	9	75	11	61
209620	753,483	4,165,801	2016	17	-200	45	1,430	35	26,610	5	11	79	-3	46
209621	753,476	4,165,897	2016	449	200	98	1,400	82	38,800	-1	8	130	-3	46
209622	753,476	4,165,998	2016	489	300	238	1,740	30	48,600	1	11	60	8	28
209623	753,475	4,166,098	2016	1,730	400	2200	5,410	39	39,900	6	13	1000	7	91
209624	753,481	4,166,202	2016	14	-200	19	1,400	43	23,600	3	15	61	-3	68

**TABLE APPENDIX J-1
2016-2017 FREMONT SOIL GEOCHEMISTRY ASSAY RESULTS**

Sample ID	Easting	Northing	Year	Au (ppb)	Ag (ppb)	As (ppm)	Ca (ppm)	Cu (ppm)	Fe (ppm)	Mo (ppm)	Pb (ppm)	S (ppm)	Sb (ppm)	Zn (ppm)
209627	753,483	4,166,397	2016	5	-200	7	2,700	48	43,700	3	12	54	-3	96
209628	753,480	4,166,499	2016	5	300	8	3,300	42	32,400	2	17	120	-3	83
209629	753,481	4,166,602	2016	7	-200	9	1,960	39	30,410	2	14	50	-3	60
209630	753,481	4,166,703	2016	8	-200	13	1,410	50	29,200	5	12	75	-3	70
209631	755,277	4,163,301	2016	4	-200	4	2,920	58	24,600	-1	8	109	-3	31
209632	755,174	4,163,301	2016	6	-200	-2	5,720	58	24,200	-1	9	229	-3	43
209633	755,079	4,163,300	2016	4	-200	2	3,060	62	26,100	-1	13	104	-3	31
209634	754,976	4,163,300	2016	3	-200	3	2,510	52	25,900	-1	8	92	-3	25
209635	754,877	4,163,303	2016	4	-200	3	2,660	63	28,800	-1	16	83	-3	25
209636	754,778	4,163,302	2016	7	-200	3	2,560	60	23,400	-1	9	93	-3	31
209637	754,677	4,163,297	2016	10	-200	2	3,050	68	24,400	-1	5	67	-3	39
209638	754,575	4,163,303	2016	193	-200	337	1,810	32	39,610	-1	5	73	5	25
209639	754,474	4,163,299	2016	63	-200	12	1,920	53	28,800	-1	21	83	-3	30
209640	754,377	4,163,301	2016	109	-200	69	2,680	60	27,800	-1	9	77	-3	34
209641	754,286	4,163,296	2016	3	-200	17	2,080	21	30,200	-1	13	62	-3	44
209642	753,981	4,164,300	2017	85	400	173	587	20	33,010	1	22	43	4	36
209643	753,977	4,164,402	2017	498	300	515	3,420	41	33,900	2	19	94	6	62
209644	753,978	4,164,501	2017	4,160	700	4210	1,910	96	78,400	-1	7	17	10	78
209645	753,976	4,164,592	2017	5,210	1900	1620	591	61	69,400	1	25	36	34	28
209646	753,981	4,164,690	2017	160	300	388	1,560	12	89,400	1	10	98	11	26
209647	753,981	4,164,799	2017	490	200	265	3,020	22	44,700	-1	8	108	7	26
209648	753,996	4,164,903	2017	6	200	10	1,610	68	38,100	-1	6	80	3	25
209649	753,977	4,165,000	2017	13	200	8	2,280	88	36,700	-1	3	70	-3	16
209650	753,980	4,165,099	2017	-3	-200	2	1,850	37	43,300	-1	-3	45	-3	22
209651	754,681	4,163,199	2016	7	-200	10	3,050	68	25,900	-1	353	79	15	36
209652	754,577	4,163,203	2016	249	-200	415	1,670	53	57,400	-1	6	33	6	37
209653	754,478	4,163,200	2016	129	-200	57	1,880	24	26,000	-1	39	85	-3	51

**TABLE APPENDIX J-1
2016-2017 FREMONT SOIL GEOCHEMISTRY ASSAY RESULTS**

Sample ID	Easting	Northing	Year	Au (ppb)	Ag (ppb)	As (ppm)	Ca (ppm)	Cu (ppm)	Fe (ppm)	Mo (ppm)	Pb (ppm)	S (ppm)	Sb (ppm)	Zn (ppm)
209654	754,383	4,163,199	2016	16	-200	31	1,550	26	29,000	1	14	68	-3	41
209655	753,577	4,162,738	2016	3	-200	14	1,360	29	35,100	2	16	77	3	57
209656	753,583	4,162,802	2016	-3	-200	10	3,210	23	31,000	1	17	86	-3	56
209657	753,585	4,162,902	2016	3	-200	12	1,730	18	31,100	1	13	51	-3	39
209658	753,582	4,162,998	2016	-3	-200	9	1,860	23	31,600	1	16	97	-3	55
209659	753,579	4,163,100	2016	3	-200	9	2,800	26	34,600	-1	18	79	-3	69
209660	753,580	4,163,200	2016	-3	-200	10	2,380	34	35,300	-1	19	88	-3	75
209661	753,578	4,163,292	2016	-3	-200	9	1,720	10	28,300	1	12	74	-3	47
209662	753,579	4,163,399	2016	-3	-200	11	730	8	25,900	1	12	48	-3	30
209663	753,574	4,163,498	2016	8	-200	13	2,330	21	32,100	1	15	103	-3	51
209664	753,580	4,163,598	2016	4	-200	12	1,300	22	27,800	-1	16	43	-3	47
209665	753,575	4,163,706	2016	3	-200	13	1,550	24	30,800	1	20	69	-3	56
209666	753,576	4,163,799	2016	4	-200	11	2,110	21	31,200	1	17	91	-3	47
209667	753,574	4,163,900	2016	4	-200	10	1,170	23	30,300	1	11	51	-3	45
209668	753,573	4,163,999	2016	4	-200	11	1,140	24	30,300	-1	12	29	-3	43
209669	753,577	4,164,101	2016	3	-200	10	4,240	20	32,200	-1	15	159	-3	52
209670	753,586	4,164,199	2016	3	-200	12	1,730	24	34,100	-1	16	141	-3	58
209671	753,580	4,164,299	2016	6	-200	16	2,870	21	31,000	2	22	139	-3	59
209672	753,571	4,164,397	2016	154	-200	58	3,300	35	35,600	1	15	119	4	64
209673	753,588	4,164,500	2016	201	-200	136	2,780	40	36,200	1	20	109	-3	71
209674	753,580	4,164,598	2016	26	-200	34	1,870	51	32,100	2	19	62	-3	84
209677	756,284	4,163,303	2016	7	-200	-2	2,440	65	27,600	-1	5	64	-3	37
209678	756,179	4,163,301	2016	3	-200	3	3,030	59	25,610	-1	5	113	-3	26
209679	756,079	4,163,301	2016	3	-200	3	2,960	57	28,500	-1	6	104	-3	32
209680	755,978	4,163,302	2016	3	-200	4	1,890	49	37,700	-1	9	104	-3	34
209681	755,881	4,163,299	2016	5	-200	-2	3,490	58	19,600	-1	3	92	-3	31
209682	755,781	4,163,298	2016	3	-200	-2	3,530	59	24,800	-1	4	92	-3	29

**TABLE APPENDIX J-1
2016-2017 FREMONT SOIL GEOCHEMISTRY ASSAY RESULTS**

Sample ID	Easting	Northing	Year	Au (ppb)	Ag (ppb)	As (ppm)	Ca (ppm)	Cu (ppm)	Fe (ppm)	Mo (ppm)	Pb (ppm)	S (ppm)	Sb (ppm)	Zn (ppm)
209683	755,680	4,163,299	2016	-3	-200	-2	3,780	56	23,310	-1	6	95	-3	31
209684	755,579	4,163,300	2016	4	-200	2	5,250	63	24,100	-1	7	156	-3	44
209685	755,480	4,163,300	2016	4	-200	2	2,010	60	27,600	-1	5	52	-3	24
209686	755,381	4,163,301	2016	-3	-200	6	2,940	72	30,600	1	18	170	-3	30
209687	753,975	4,165,203	2017	4	-200	8	2,500	45	42,000	-1	4	66	-3	31
209688	753,979	4,165,301	2017	26	-200	3	1,260	54	38,500	-1	5	56	-3	30
209689	753,877	4,165,300	2017	276	200	193	2,950	39	62,300	-1	7	115	6	30
209690	753,879	4,165,403	2017	116	-200	9	847	18	49,200	-1	321	54	7	23
209691	753,880	4,165,499	2017	-3	-200	7	1,060	17	39,000	-1	4	62	-3	16
209692	753,879	4,165,597	2017	14	-200	12	2,250	22	44,900	-1	4	94	-3	22
209693	753,881	4,165,705	2017	49	-200	3	1,970	38	58,600	-1	4	70	4	32
209694	753,879	4,165,802	2017	6	-200	-2	1,000	29	41,000	-1	-3	55	-3	17
209695	753,880	4,165,899	2017	16	-200	14	712	42	59,100	-1	-3	25	5	21
209696	753,879	4,165,975	2017	9	-200	4	898	27	34,410	-1	3	42	4	20
209697	754,084	4,164,091	2017	179	500	65	2,960	163	81,000	-1	12	248	4	69
209698	754,090	4,164,203	2017	2,990	600	585	2,130	45	67,300	-1	9	30	15	36
209699	754,086	4,164,300	2017	256	200	336	1,690	23	55,100	-1	6	41	6	32
209700	754,097	4,164,409	2017	48	-200	247	1,690	25	61,900	1	7	40	6	22
209701	753,679	4,162,999	2016	5	-200	13	2,270	29	36,400	1	23	107	-3	63
209702	753,681	4,163,102	2016	5	-200	16	637	28	34,100	1	15	38	-3	55
209703	753,678	4,163,203	2016	7	200	14	1,240	9	29,800	1	12	71	-3	33
209704	753,683	4,163,301	2016	3	-200	10	3,400	18	31,100	1	17	125	-3	58
209705	753,672	4,163,401	2016	4	-200	10	2,200	22	31,100	-1	15	68	-3	62
209706	753,679	4,163,503	2016	8	-200	15	1,590	36	34,400	1	23	51	-3	62
209707	753,684	4,163,599	2016	5	-200	14	2,140	35	33,900	1	18	74	-3	68
209708	753,675	4,163,698	2016	4	-200	13	1,770	22	32,300	1	13	65	-3	44
209709	753,688	4,163,804	2016	3	-200	10	1,070	18	32,700	1	13	55	-3	36

**TABLE APPENDIX J-1
2016-2017 FREMONT SOIL GEOCHEMISTRY ASSAY RESULTS**

Sample ID	Easting	Northing	Year	Au (ppb)	Ag (ppb)	As (ppm)	Ca (ppm)	Cu (ppm)	Fe (ppm)	Mo (ppm)	Pb (ppm)	S (ppm)	Sb (ppm)	Zn (ppm)
209710	753,673	4,163,904	2016	-3	-200	12	2,560	16	27,900	1	16	98	-3	39
209711	753,676	4,164,002	2016	3	-200	20	2,650	9	25,400	2	21	145	-3	36
209712	753,682	4,164,098	2016	3	-200	14	2,500	6	20,300	2	33	130	-3	41
209713	753,683	4,164,196	2016	3	-200	14	1,610	25	33,700	1	19	77	-3	56
209714	753,678	4,164,297	2016	4	-200	14	3,740	25	35,600	1	19	176	-3	61
209715	753,681	4,164,394	2016	6	-200	16	1,930	20	29,000	-1	17	51	-3	62
209716	753,680	4,164,500	2016	7	-200	21	1,300	29	35,400	-1	13	39	3	61
209717	753,680	4,164,599	2016	12	-200	28	1,470	26	28,200	-1	14	42	-3	45
209718	755,283	4,163,400	2016	4	-200	-2	5,480	69	30,000	-1	11	136	-3	34
209719	755,178	4,163,407	2016	4	-200	-2	4,430	56	21,900	-1	5	148	-3	34
209720	755,083	4,163,401	2016	3	-200	2	2,970	59	25,400	-1	3	67	-3	30
209721	754,982	4,163,401	2016	4	-200	3	3,530	48	25,600	-1	8	144	-3	31
209722	754,885	4,163,399	2016	9	-200	-2	3,110	48	25,900	-1	6	95	-3	29
209723	754,782	4,163,403	2016	13	-200	2	3,390	73	29,700	-1	7	91	-3	34
209724	754,682	4,163,403	2016	4	-200	-2	3,390	54	23,500	-1	5	106	-3	33
209727	754,481	4,163,397	2016	5	-200	6	3,220	52	29,000	-1	7	97	-3	25
209728	754,379	4,163,401	2016	250	-200	182	1,950	9	13,300	1	26	91	-3	29
209729	754,280	4,163,417	2016	41	-200	32	1,270	20	31,500	1	12	90	-3	44
209730	753,879	4,164,309	2017	15	-200	36	1,170	29	30,300	-1	13	39	-3	45
209731	753,878	4,164,400	2017	183	-200	122	1,750	19	29,200	-1	12	63	3	39
209732	753,874	4,164,500	2017	556	-200	319	1,810	33	42,200	1	23	71	6	67
209733	753,879	4,164,604	2017	1440	500	397	1,440	46	34,500	2	21	79	9	60
209734	753,883	4,164,702	2017	236	-200	133	1,030	32	33,100	2	27	54	5	41
209735	753,877	4,164,795	2017	87	-200	52	1,140	7	18,210	1	30	40	-3	37
209736	753,881	4,164,901	2017	1120	700	623	3,960	50	46,800	1	63	260	8	85
209737	753,911	4,165,002	2017	263	300	94	1,100	85	25,400	-1	-3	28	4	9
209738	753,907	4,165,108	2017	17	-200	12	1,300	22	53,100	-1	7	84	4	26

**TABLE APPENDIX J-1
2016-2017 FREMONT SOIL GEOCHEMISTRY ASSAY RESULTS**

Sample ID	Easting	Northing	Year	Au (ppb)	Ag (ppb)	As (ppm)	Ca (ppm)	Cu (ppm)	Fe (ppm)	Mo (ppm)	Pb (ppm)	S (ppm)	Sb (ppm)	Zn (ppm)
209739	753,878	4,165,201	2017	205	-200	133	3,470	22	53,500	-1	31	206	6	35
209740	753,776	4,165,188	2017	170	300	1170	560	24	44,100	-1	4	35	10	8
209741	753,779	4,165,297	2017	6	-200	10	757	22	62,500	-1	7	64	5	35
209742	753,780	4,165,401	2017	3	-200	3	655	29	84,200	-1	5	58	5	46
209743	753,778	4,165,499	2017	3	-200	2	1,040	21	71,600	-1	5	92	4	33
209744	753,780	4,165,600	2017	113	-200	4	955	13	68,300	-1	5	81	4	28
209745	753,780	4,165,699	2017	6	-200	4	2,260	19	58,500	-1	4	135	4	28
209746	753,790	4,165,800	2017	258	200	95	1,360	18	72,900	-1	7	82	7	23
209747	753,777	4,165,904	2017	184	-200	56	1,320	28	65,900	-1	8	73	6	30
209748	753,778	4,165,998	2017	19	-200	12	759	22	60,100	-1	4	67	7	26
209749	753,777	4,166,099	2017	4	-200	4	3,370	83	33,100	-1	6	51	-3	58
209750	754,184	4,164,102	2017	324	-200	41	2,360	113	60,600	-1	6	37	-3	46
209751	754,179	4,164,209	2017	265	300	36	1,470	96	109,000	-1	7	32	5	48
209752	754,182	4,164,298	2017	44	200	49	2,810	33	65,100	-1	10	126	-3	29
209753	754,172	4,164,396	2017	9	-200	40	939	28	52,600	-1	5	23	3	16
209754	754,180	4,164,492	2017	23	-200	61	1,900	68	38,500	-1	3	38	-3	10
209755	754,180	4,164,604	2017	7	-200	6	2,610	33	30,800	-1	-3	70	-3	20
209756	754,178	4,164,699	2017	17	-200	13	1,500	32	38,100	-1	3	76	-3	19
209757	754,177	4,164,801	2017	9	-200	4	2,610	90	30,500	-1	3	47	-3	30
209758	754,176	4,164,899	2017	14	-200	4	2,620	83	32,800	-1	5	79	-3	27
209759	754,180	4,165,000	2017	9	-200	10	1,950	68	26,500	-1	-3	38	-3	31
209760	754,178	4,165,101	2017	9	-200	8	2,190	68	26,900	-1	-3	52	-3	29
209761	754,179	4,165,205	2017	5	-200	4	1,620	57	26,700	-1	7	52	-3	18
209762	754,181	4,165,302	2017	18	-200	15	2,800	60	29,800	-1	9	90	-3	26
209763	754,180	4,165,400	2017	9	-200	7	3,200	79	31,900	-1	8	94	-3	33
209764	754,180	4,165,501	2017	6	-200	4	6,680	58	23,800	-1	12	235	-3	42
209765	754,081	4,165,503	2017	3	-200	3	2,270	54	22,800	-1	6	73	-3	27

**TABLE APPENDIX J-1
2016-2017 FREMONT SOIL GEOCHEMISTRY ASSAY RESULTS**

Sample ID	Easting	Northing	Year	Au (ppb)	Ag (ppb)	As (ppm)	Ca (ppm)	Cu (ppm)	Fe (ppm)	Mo (ppm)	Pb (ppm)	S (ppm)	Sb (ppm)	Zn (ppm)
209766	754,079	4,165,601	2017	3	-200	2	2,540	62	22,500	-1	5	73	-3	29
209767	754,078	4,165,699	2017	19	-200	2	2,600	73	28,900	-1	5	71	-3	33
209768	754,088	4,165,798	2017	3	-200	5	4,230	87	30,700	-1	8	132	-3	40
209769	754,081	4,165,873	2017	8	-200	4	5,390	71	25,400	-1	8	137	-3	39
209770	754,481	4,164,101	2017	17	-200	11	2,470	65	22,500	-1	7	54	-3	29
209771	754,481	4,164,198	2017	27	-200	22	2,450	72	23,400	-1	6	55	-3	37
209772	754,478	4,164,297	2017	12	-200	8	2,420	71	24,400	-1	8	82	-3	32
209773	754,481	4,164,401	2017	4	-200	4	1,920	67	26,700	-1	7	58	-3	25
209774	754,481	4,164,500	2017	4	-200	4	2,060	64	25,600	-1	6	45	-3	27
209775	754,479	4,164,600	2017	9	-200	5	1,960	68	33,200	-1	6	68	-3	25
209776	754,478	4,164,600	2017	8	-200	5	1,930	64	29,900	-1	6	71	-3	21
209777	754,482	4,164,701	2017	5	-200	5	2,140	77	36,600	-1	8	78	-3	34
209778	754,480	4,164,802	2017	5	-200	5	2,980	82	26,400	-1	8	105	-3	28
209779	754,478	4,164,899	2017	3	-200	4	2,020	71	26,000	-1	6	56	-3	22
209780	754,479	4,165,000	2017	6	-200	2	2,080	81	26,000	-1	6	55	-3	27
209781	754,480	4,165,099	2017	7	-200	4	2,950	73	23,100	-1	6	92	-3	31
209782	754,477	4,165,199	2017	6	-200	4	2,270	74	24,900	-1	5	69	-3	30
209783	754,478	4,165,300	2017	14	-200	12	2,830	85	30,400	-1	6	71	-3	30
209784	754,480	4,165,402	2017	215	-200	15	2,180	70	23,900	-1	7	44	-3	27
209785	754,483	4,165,499	2017	18	-200	12	3,260	81	25,600	-1	5	75	-3	32
209786	754,482	4,165,600	2017	-3	-200	6	1,710	59	34,700	-1	6	39	-3	27
209787	754,478	4,165,695	2017	7	-200	22	929	39	24,300	2	14	52	-3	55
209788	754,484	4,165,791	2017	5	200	9	1,400	36	25,200	3	14	45	-3	44
209789	754,383	4,165,781	2017	5	-200	13	1,220	25	27,000	2	13	47	-3	41
209790	755,081	4,163,800	2017	5	-200	-2	2,670	60	21,000	-1	4	60	-3	31
209791	755,080	4,163,901	2017	9	-200	3	3,060	72	27,400	-1	7	71	-3	32
209792	755,080	4,164,000	2017	3	-200	3	4,590	61	25,500	-1	8	176	-3	36

**TABLE APPENDIX J-1
2016-2017 FREMONT SOIL GEOCHEMISTRY ASSAY RESULTS**

Sample ID	Easting	Northing	Year	Au (ppb)	Ag (ppb)	As (ppm)	Ca (ppm)	Cu (ppm)	Fe (ppm)	Mo (ppm)	Pb (ppm)	S (ppm)	Sb (ppm)	Zn (ppm)
209793	755,079	4,164,096	2017	3	-200	4	2,780	75	28,700	-1	8	135	-3	50
209794	755,078	4,164,199	2017	9	-200	4	3,750	52	25,200	-1	10	153	-3	50
209795	755,079	4,164,303	2017	6	-200	5	2,270	86	33,200	-1	7	51	-3	42
209796	755,078	4,164,399	2017	10	-200	8	3,070	99	31,900	-1	7	99	-3	39
209797	755,077	4,164,498	2017	21	-200	13	1,940	112	33,200	1	9	94	-3	40
209798	755,078	4,164,589	2017	14	-200	8	3,270	73	29,900	-1	9	83	-3	40
209799	755,077	4,164,702	2017	16	-200	9	2,400	92	41,500	-1	5	62	-3	37
209800	755,080	4,164,802	2017	31	-200	6	3,200	99	35,200	-1	8	92	-3	57
209801	753,779	4,162,901	2016	3	-200	19	1,200	27	30,300	1	14	66	-3	60
209802	753,775	4,163,001	2016	3	-200	11	1,210	22	26,700	1	15	60	-3	45
209803	753,779	4,163,097	2016	3	-200	12	2,300	32	30,700	1	16	98	-3	55
209804	753,782	4,163,199	2016	3	-200	11	1,340	24	25,110	-1	17	39	-3	36
209805	753,777	4,163,296	2016	4	-200	12	1,040	37	27,200	1	20	44	-3	58
209806	753,777	4,163,401	2016	5	-200	13	1,210	35	32,100	2	21	61	-3	56
209807	753,775	4,163,500	2016	3	-200	11	1,270	24	26,510	1	13	49	-3	41
209808	753,780	4,163,596	2016	3	-200	11	1,050	18	25,300	1	15	50	-3	34
209809	753,780	4,163,697	2016	-3	-200	15	1,080	8	17,900	2	23	76	-3	27
209810	753,776	4,163,794	2016	-3	-200	15	561	8	14,300	2	22	45	-3	31
209811	753,780	4,163,898	2016	3	-200	8	1,110	28	25,900	1	16	51	-3	46
209812	753,778	4,163,999	2016	3	-200	20	1,960	26	29,400	1	19	94	-3	46
209813	753,780	4,164,101	2016	4	-200	17	2,010	31	27,500	1	26	174	-3	54
209814	753,780	4,164,199	2016	8	-200	26	1,310	63	36,300	2	28	72	-3	92
209815	753,778	4,164,299	2016	10	-200	20	1,050	30	28,310	-1	15	37	-3	45
209816	753,779	4,164,402	2016	11	-200	19	2,070	27	25,800	-1	15	85	-3	45
209817	753,779	4,164,500	2016	16	-200	32	1,030	28	26,500	1	14	48	-3	41
209818	753,781	4,164,599	2016	64	-200	46	1,210	32	24,500	1	19	56	-3	46
209819	753,779	4,164,699	2016	7	-200	20	1,290	12	14,510	1	31	63	-3	28

**TABLE APPENDIX J-1
2016-2017 FREMONT SOIL GEOCHEMISTRY ASSAY RESULTS**

Sample ID	Easting	Northing	Year	Au (ppb)	Ag (ppb)	As (ppm)	Ca (ppm)	Cu (ppm)	Fe (ppm)	Mo (ppm)	Pb (ppm)	S (ppm)	Sb (ppm)	Zn (ppm)
209820	753,781	4,164,804	2016	38	-200	23	681	7	12,000	2	46	76	-3	19
209821	756,378	4,163,405	2016	8	-200	3	2,690	68	29,600	-1	7	99	-3	36
209822	756,280	4,163,400	2016	11	-200	-2	2,440	82	23,800	-1	4	61	-3	31
209823	756,179	4,163,400	2016	5	-200	3	3,020	82	24,900	-1	5	93	-3	31
209824	756,080	4,163,399	2016	4	-200	5	3,170	83	41,700	-1	11	124	-3	42
209825	755,980	4,163,399	2016	5	-200	2	3,140	71	23,800	-1	4	80	-3	32
209826	755,978	4,163,398	2016	5	-200	-2	2,880	65	22,100	-1	4	72	-3	28
209827	755,880	4,163,399	2016	3	-200	2	3,380	59	24,400	-1	7	120	-3	28
209828	755,778	4,163,399	2016	4	-200	2	3,630	73	23,300	-1	7	148	-3	36
209829	755,678	4,163,398	2016	3	-200	-2	3,630	69	23,310	-1	5	101	-3	33
209830	755,581	4,163,400	2016	3	-200	3	4,270	85	29,400	-1	4	89	-3	38
209831	755,478	4,163,399	2016	-3	-200	2	3,260	76	27,600	-1	5	95	-3	38
209832	755,380	4,163,401	2016	3	-200	2	2,680	82	27,300	-1	4	70	-3	32
209833	753,769	4,165,089	2017	1,350	600	877	16,700	31	27,900	2	9	947	8	46
209834	753,781	4,164,995	2017	95	200	263	1,880	34	80,800	1	13	106	27	37
209835	753,776	4,164,891	2017	15	-200	27	1,440	22	27,300	1	16	81	3	50
209836	753,684	4,164,803	2017	66	-200	47	1,300	20	18,400	1	31	54	-3	35
209837	753,683	4,164,702	2017	22	-200	48	1,150	34	26,600	-1	23	42	-3	49
209838	753,679	4,164,895	2017	4	-200	15	1,910	11	19,500	1	23	72	-3	42
209839	753,681	4,164,996	2017	7	-200	24	1,690	23	23,500	2	29	79	3	45
209840	753,679	4,165,095	2017	221	200	377	1,980	25	68,000	-1	9	81	27	23
209841	753,695	4,165,216	2017	26	300	123	1,310	44	30,800	1	11	64	-3	66
209842	753,677	4,165,313	2017	15	-200	13	1,640	25	41,000	-1	11	108	3	35
209843	753,681	4,165,398	2017	4	-200	6	1,290	9	44,300	-1	6	120	4	22
209844	753,675	4,165,503	2017	17	-200	10	1,290	12	41,000	-1	6	91	3	28
209845	753,683	4,165,600	2017	3	300	5	2,080	18	35,700	-1	4	89	-3	25
209846	753,686	4,165,701	2017	6	-200	7	1,940	28	46,600	-1	4	95	3	27

**TABLE APPENDIX J-1
2016-2017 FREMONT SOIL GEOCHEMISTRY ASSAY RESULTS**

Sample ID	Easting	Northing	Year	Au (ppb)	Ag (ppb)	As (ppm)	Ca (ppm)	Cu (ppm)	Fe (ppm)	Mo (ppm)	Pb (ppm)	S (ppm)	Sb (ppm)	Zn (ppm)
209847	753,687	4,165,810	2017	113	-200	93	2,070	24	36,900	1	9	118	3	37
209848	753,675	4,165,899	2017	67	-200	112	1,620	24	32,600	1	9	92	4	35
209849	753,679	4,166,002	2017	26	-200	6	658	17	38,500	-1	4	47	3	23
209850	753,676	4,166,101	2017	32	-200	22	2,430	41	25,900	9	16	93	5	153
209851	753,679	4,166,200	2017	19	400	17	1,990	46	26,500	8	17	106	4	146
209852	753,678	4,166,301	2017	10	700	8	2,940	64	28,400	1	18	130	-3	80
209853	754,285	4,164,111	2017	1,790	300	45	1,950	74	128,000	-1	5	72	7	81
209854	754,278	4,164,198	2017	30	-200	15	1,730	26	42,900	-1	6	76	-3	21
209855	754,284	4,164,297	2017	27	-200	19	1,100	45	55,400	-1	7	54	3	14
209856	754,282	4,164,396	2017	27	-200	15	2,180	47	61,200	-1	7	155	-3	27
209857	754,284	4,164,493	2017	6	-200	8	2,620	57	32,900	-1	5	83	-3	26
209858	754,283	4,164,596	2017	7	-200	18	1,660	35	53,900	-1	7	130	-3	37
209859	754,287	4,164,695	2017	6	-200	5	2,560	87	29,200	-1	5	72	-3	31
209860	754,278	4,164,794	2017	7	-200	3	2,620	84	31,500	-1	7	101	-3	41
209861	754,283	4,164,899	2017	28	-200	5	3,200	87	36,400	-1	9	137	-3	41
209862	754,283	4,164,997	2017	9	-200	6	3,700	82	31,000	-1	8	136	-3	41
209863	754,280	4,165,101	2017	7	-200	7	2,310	68	24,900	-1	4	56	-3	27
209864	754,274	4,165,201	2017	5	-200	4	2,810	63	22,500	-1	6	83	-3	25
209865	754,281	4,165,296	2017	24	-200	33	2,630	67	30,300	-1	7	82	-3	28
209866	754,287	4,165,396	2017	8	-200	11	4,990	67	28,500	-1	7	130	-3	40
209867	754,281	4,165,498	2017	5	-200	7	5,200	71	22,500	-1	10	148	-3	39
209868	754,280	4,165,598	2017	5	-200	5	3,150	69	29,800	-1	7	123	-3	38
209869	754,176	4,165,607	2017	3	-200	5	4,730	108	30,700	-1	5	57	-3	41
209870	754,178	4,165,696	2017	4	-200	4	2,510	64	25,600	-1	7	73	-3	28
209871	754,179	4,165,798	2017	-3	-200	4	2,810	57	25,800	-1	7	78	-3	33
209872	754,580	4,164,102	2017	11	-200	12	2,660	70	25,900	-1	7	73	-3	25
209873	754,584	4,164,201	2017	4	-200	5	4,260	59	23,600	-1	8	165	-3	38

**TABLE APPENDIX J-1
2016-2017 FREMONT SOIL GEOCHEMISTRY ASSAY RESULTS**

Sample ID	Easting	Northing	Year	Au (ppb)	Ag (ppb)	As (ppm)	Ca (ppm)	Cu (ppm)	Fe (ppm)	Mo (ppm)	Pb (ppm)	S (ppm)	Sb (ppm)	Zn (ppm)
209874	754,583	4,164,301	2017	7	-200	7	2,200	60	23,100	-1	6	52	-3	29
209877	754,580	4,164,503	2017	4	-200	6	1,300	106	19,300	2	11	284	-3	30
209878	754,581	4,164,600	2017	13	-200	6	2,320	81	26,500	-1	11	98	-3	52
209879	754,580	4,164,699	2017	15	-200	8	2,560	87	36,700	-1	10	128	-3	46
209880	754,577	4,164,796	2017	5	-200	5	3,010	107	38,500	-1	8	77	-3	44
209881	754,580	4,164,895	2017	6	-200	6	3,360	91	25,500	-1	16	166	-3	50
209882	754,566	4,164,985	2017	4	-200	5	2,370	57	25,600	-1	7	119	-3	31
209883	754,578	4,165,101	2017	6	-200	4	2,620	64	18,900	-1	6	100	-3	28
209884	754,579	4,165,201	2017	6	-200	5	2,410	70	20,500	-1	5	70	-3	28
209885	754,584	4,165,287	2017	5	-200	4	2,590	76	25,100	-1	5	79	-3	29
209886	754,576	4,165,404	2017	15	-200	23	3,350	86	30,300	-1	7	133	-3	37
209887	754,571	4,165,499	2017	4	-200	6	2,720	85	23,900	-1	6	78	-3	29
209888	754,579	4,165,592	2017	4	-200	8	1,320	30	26,000	2	12	52	-3	43
209889	754,581	4,165,699	2017	6	200	13	2,770	41	25,700	2	12	80	-3	62
209890	754,571	4,165,805	2017	7	-200	8	1,810	42	22,900	2	13	77	-3	48
209891	754,982	4,163,799	2017	9	-200	3	4,090	58	25,000	-1	6	125	-3	32
209892	754,984	4,163,901	2017	3	-200	2	3,110	56	19,500	-1	4	94	-3	33
209893	754,982	4,163,995	2017	4	-200	3	3,130	55	20,800	-1	7	112	-3	36
209894	754,983	4,164,095	2017	4	-200	4	3,360	68	28,000	-1	7	119	-3	36
209895	754,984	4,164,201	2017	4	-200	5	4,270	65	28,800	-1	9	141	-3	49
209896	754,978	4,164,297	2017	4	-200	6	4,110	58	27,700	-1	9	197	-3	53
209897	754,983	4,164,400	2017	5	-200	6	2,900	82	29,000	-1	5	68	-3	50
209898	754,984	4,164,502	2017	16	-200	9	2,760	92	36,100	-1	6	95	-3	35
209899	754,974	4,164,596	2017	9	-200	7	3,060	102	26,810	-1	8	96	-3	37
209900	754,982	4,164,698	2017	8	-200	10	2,640	82	32,500	1	11	108	-3	43
209901	753,580	4,164,701	2017	10	-200	26	1,830	48	33,300	-1	20	48	4	73
209902	753,580	4,164,798	2017	4	-200	13	4,470	26	23,510	-1	18	106	-3	58

**TABLE APPENDIX J-1
2016-2017 FREMONT SOIL GEOCHEMISTRY ASSAY RESULTS**

Sample ID	Easting	Northing	Year	Au (ppb)	Ag (ppb)	As (ppm)	Ca (ppm)	Cu (ppm)	Fe (ppm)	Mo (ppm)	Pb (ppm)	S (ppm)	Sb (ppm)	Zn (ppm)
209903	753,577	4,164,896	2017	9	-200	21	1,060	25	23,300	1	18	37	-3	40
209904	753,580	4,164,999	2017	3	-200	15	1,800	13	16,800	-1	26	90	-3	39
209905	753,573	4,165,105	2017	23	-200	23	1,680	14	17,700	-1	22	96	-3	52
209906	753,585	4,165,197	2017	130	-200	160	1,630	34	36,200	1	12	57	7	37
209907	753,582	4,165,302	2017	152	-200	139	1,110	15	46,400	-1	5	30	22	10
209908	753,579	4,165,394	2017	65	-200	88	4,030	34	37,100	-1	13	143	5	36
209909	753,576	4,165,500	2017	58	200	60	232	46	29,300	2	13	42	6	50
209910	753,575	4,165,600	2017	9	-200	22	1,350	24	28,000	2	12	54	-3	69
209911	753,576	4,165,697	2017	13	-200	46	1,050	23	31,700	-1	7	100	4	28
209912	753,589	4,165,797	2017	4	-200	5	1,080	31	35,600	-1	4	47	-3	28
209913	753,579	4,165,901	2017	12	-200	5	593	14	52,000	-1	5	60	8	25
209914	753,581	4,165,998	2017	45	200	18	686	25	41,100	-1	4	53	-3	32
209915	753,580	4,166,104	2017	25	-200	24	1,970	48	25,400	11	15	73	7	155
209916	753,576	4,166,190	2017	15	-200	24	1,420	26	15,100	9	17	81	4	124
209917	753,583	4,166,296	2017	19	500	12	4,230	50	25,700	2	14	95	-3	83
209918	753,585	4,166,401	2017	17	300	10	2,390	47	26,700	3	12	57	-3	65
209919	753,586	4,166,502	2017	4	-200	8	3,270	45	25,100	3	13	147	-3	57
209920	753,582	4,166,597	2017	3	-200	5	1,360	24	26,300	2	12	52	-3	60
209921	754,382	4,164,104	2017	9	300	15	3,480	70	31,900	-1	7	83	-3	36
209922	754,379	4,164,199	2017	5	-200	8	2,720	89	27,600	-1	8	67	-3	36
209923	754,383	4,164,285	2017	14	-200	13	3,930	71	24,500	-1	7	134	-3	37
209924	754,381	4,164,398	2017	6	-200	4	3,280	67	25,700	-1	7	109	-3	35
209927	754,378	4,164,604	2017	7	-200	7	2,880	64	24,800	-1	9	90	-3	34
209928	754,377	4,164,700	2017	7	-200	5	2,080	83	25,900	-1	4	43	-3	33
209929	754,379	4,164,803	2017	5	-200	4	2,720	90	23,000	-1	5	69	-3	27
209930	754,380	4,164,901	2017	11	-200	4	3,930	84	26,700	-1	5	87	-3	34
209931	754,382	4,164,995	2017	5	-200	5	3,070	73	29,500	-1	6	89	-3	38

**TABLE APPENDIX J-1
2016-2017 FREMONT SOIL GEOCHEMISTRY ASSAY RESULTS**

Sample ID	Easting	Northing	Year	Au (ppb)	Ag (ppb)	As (ppm)	Ca (ppm)	Cu (ppm)	Fe (ppm)	Mo (ppm)	Pb (ppm)	S (ppm)	Sb (ppm)	Zn (ppm)
209932	754,382	4,165,095	2017	6	-200	5	3,990	69	27,600	-1	7	142	-3	39
209933	754,376	4,165,197	2017	4	-200	5	2,880	71	26,700	-1	4	71	-3	32
209934	754,379	4,165,299	2017	10	-200	16	2,340	68	29,400	-1	8	84	-3	32
209935	754,384	4,165,398	2017	128	-200	21	2,950	72	25,800	-1	6	67	-3	36
209936	754,389	4,165,500	2017	-3	-200	4	5,250	72	27,500	-1	5	130	-3	40
209937	754,379	4,165,598	2017	6	-200	6	4,410	99	28,800	-1	5	94	-3	35
209938	754,379	4,165,700	2017	9	-200	29	2,240	43	25,700	4	10	54	-3	60
209939	754,285	4,165,699	2017	3	-200	6	2,690	59	30,300	-1	7	57	-3	36
209940	754,278	4,165,795	2017	27	-200	21	1,430	61	29,000	1	9	55	-3	53
209941	754,681	4,164,002	2017	7	-200	5	3,410	67	28,900	-1	20	144	-3	42
209942	754,678	4,164,099	2017	6	-200	7	2,410	83	40,800	-1	17	109	-3	52
209943	754,677	4,164,801	2017	5	-200	12	2,860	83	37,400	1	16	80	-3	55
209944	754,682	4,164,200	2017	9	-200	13	3,190	84	32,200	-1	13	109	-3	43
209945	754,677	4,164,293	2017	4	200	10	3,800	80	30,900	-1	14	161	-3	45
209946	754,684	4,164,400	2017	3	-200	8	3,200	98	31,600	-1	13	104	-3	40
209947	754,681	4,164,495	2017	8	200	7	13,000	107	32,500	-1	14	92	-3	43
209948	754,678	4,164,598	2017	4	-200	5	3,040	99	30,400	-1	14	77	-3	35
209949	754,677	4,164,695	2017	6	-200	6	2,430	86	39,100	-1	17	87	-3	43
209950	754,680	4,164,897	2017	9	-200	4	3,990	96	30,900	-1	19	109	-3	39
209951	754,680	4,164,999	2017	9	-200	3	2,660	89	26,800	-1	17	137	-3	46
209952	754,681	4,165,098	2017	-3	-200	3	3,190	78	22,400	-1	10	86	-3	39
209953	754,678	4,165,195	2017	-3	-200	4	3,560	74	21,200	-1	7	68	-3	33
209954	754,679	4,165,293	2017	3	-200	4	3,390	87	25,900	-1	10	69	-3	34
209955	754,679	4,165,392	2017	3	-200	5	2,920	68	33,200	-1	11	97	-3	50
209956	754,679	4,165,498	2017	3	-200	5	3,190	49	26,600	1	13	104	-3	55
209957	754,680	4,165,597	2017	16	-200	8	2,030	66	36,100	1	16	79	-3	28
209958	754,681	4,165,701	2017	5	-200	13	1,870	45	27,600	2	21	79	-3	41

**TABLE APPENDIX J-1
2016-2017 FREMONT SOIL GEOCHEMISTRY ASSAY RESULTS**

Sample ID	Easting	Northing	Year	Au (ppb)	Ag (ppb)	As (ppm)	Ca (ppm)	Cu (ppm)	Fe (ppm)	Mo (ppm)	Pb (ppm)	S (ppm)	Sb (ppm)	Zn (ppm)
209959	754,673	4,165,802	2017	6	-200	7	1,790	42	23,000	-1	27	66	-3	63
209960	754,880	4,163,798	2017	4	-200	-2	3,570	69	20,500	-1	10	76	-3	37
209961	754,883	4,163,903	2017	-3	-200	3	3,320	64	20,300	-1	12	79	-3	35
209962	754,879	4,164,001	2017	-3	-200	3	2,750	53	19,900	-1	8	72	-3	38
209963	754,882	4,164,100	2017	-3	-200	3	3,950	67	25,600	-1	13	199	-3	56
209964	754,885	4,164,196	2017	-3	-200	4	3,790	70	25,400	-1	15	138	-3	53
209965	754,881	4,164,293	2017	33	-200	13	3,320	80	29,600	-1	10	99	-3	45
209966	754,878	4,164,395	2017	4	-200	8	5,980	46	20,700	-1	18	171	-3	47
209967	754,884	4,164,499	2017	10	-200	32	5,810	93	30,600	-1	16	180	-3	48
209968	754,880	4,164,597	2017	5	-200	6	3,290	86	29,400	-1	12	136	-3	47
209969	754,872	4,164,698	2017	22	-200	18	5,740	104	32,900	-1	22	162	-3	54
209970	754,878	4,164,793	2017	7	-200	5	2,800	103	28,700	-1	12	77	-3	39
209971	754,884	4,164,901	2017	3	-200	9	3,300	96	31,800	-1	17	79	-3	42
209972	754,879	4,165,004	2017	11	-200	6	2,510	90	33,800	-1	14	67	-3	41
209973	754,879	4,165,096	2017	7	-200	8	2,500	81	32,500	-1	14	50	-3	36
209974	754,879	4,165,198	2017	6	-200	20	2,380	87	33,700	-1	10	78	-3	37
209977	754,881	4,165,390	2017	9	-200	18	3,340	140	47,200	1	17	59	-3	66
209978	754,882	4,165,499	2017	-3	-200	7	2,550	46	29,300	2	17	90	-3	50
209979	754,881	4,165,592	2017	4	-200	35	2,630	24	27,500	1	17	56	-3	51
209980	754,879	4,165,706	2017	7	200	7	1,760	41	29,200	-1	29	48	-3	63
209981	754,884	4,165,807	2017	-3	-200	3	1,470	34	30,600	2	19	62	-3	81
209982	755,481	4,163,503	2017	-3	-200	2	2,490	60	22,000	-1	9	66	-3	34
209983	755,478	4,163,599	2017	-3	-200	3	2,650	70	23,100	-1	11	89	-3	31
209984	755,478	4,163,700	2017	3	-200	2	2,860	49	19,000	-1	14	94	-3	29
209985	755,480	4,163,802	2017	4	-200	4	2,220	71	31,400	-1	12	78	-3	56
209986	755,478	4,163,904	2017	3	-200	2	4,380	68	29,600	-1	16	114	-3	48
209987	755,481	4,164,012	2017	4	-200	4	5,400	70	34,000	-1	19	145	-3	50

**TABLE APPENDIX J-1
2016-2017 FREMONT SOIL GEOCHEMISTRY ASSAY RESULTS**

Sample ID	Easting	Northing	Year	Au (ppb)	Ag (ppb)	As (ppm)	Ca (ppm)	Cu (ppm)	Fe (ppm)	Mo (ppm)	Pb (ppm)	S (ppm)	Sb (ppm)	Zn (ppm)
209988	755,484	4,164,106	2017	5	-200	3	3,970	75	34,200	-1	16	128	-3	68
209989	755,473	4,164,203	2017	5	-200	4	4,150	76	29,600	-1	14	108	-3	65
209990	755,484	4,164,301	2017	11	-200	4	3,590	85	32,800	-1	20	134	-3	69
209991	755,475	4,164,396	2017	4	-200	4	5,240	76	31,000	-1	17	123	-3	67
209992	755,474	4,164,501	2017	6	-200	6	7,580	80	28,900	-1	16	313	-3	60
209993	755,485	4,164,599	2017	16	-200	4	4,630	88	40,200	-1	16	133	-3	54
209994	755,482	4,164,691	2017	4	-200	3	4,720	91	41,600	-1	11	97	-3	50
209995	755,476	4,164,793	2017	6	-200	5	2,990	65	28,300	-1	15	79	-3	38
209996	755,475	4,164,900	2017	8	-200	5	3,890	76	28,600	-1	17	91	-3	53
209997	755,480	4,164,997	2017	5	-200	6	6,100	81	33,900	-1	13	147	-3	50
209998	755,473	4,165,104	2017	5	-200	6	3,230	67	34,100	-1	21	107	-3	46
209999	755,484	4,165,200	2017	43	-200	40	3,220	81	32,400	-1	13	68	-3	42
210000	755,481	4,165,301	2017	17	-200	16	2,860	61	31,700	-1	15	108	-3	40
210001	755,380	4,163,001	2016	4	-200	5	2,730	74	32,300	-1	31	270	-3	39
210002	755,279	4,163,001	2016	3	-200	3	3,340	59	23,900	-1	10	147	-3	36
210003	755,178	4,163,001	2016	4	-200	4	4,750	58	20,200	-1	11	156	-3	43
210004	755,080	4,163,000	2016	4	200	3	2,020	54	26,700	-1	6	74	-3	26
210005	754,980	4,163,000	2016	5	-200	3	2,890	75	27,600	-1	8	91	-3	32
210006	754,882	4,163,001	2016	5	-200	4	4,170	75	23,500	-1	8	106	-3	34
210007	754,777	4,162,997	2016	6	-200	3	1,960	58	23,900	-1	8	108	-3	30
210008	754,679	4,162,999	2016	159	300	145	2,030	65	35,600	2	17	102	5	54
210009	754,581	4,162,999	2016	397	200	400	1,800	51	52,900	1	17	79	7	49
210010	754,478	4,162,999	2016	14	-200	35	1,540	18	20,100	1	19	79	-3	36
210011	754,381	4,162,999	2016	88	300	68	2,490	33	27,600	-1	18	120	-3	44
210012	754,280	4,163,000	2016	8	-200	14	2,000	34	27,500	-1	16	88	-3	54
210013	754,183	4,163,005	2016	18	-200	22	3,000	30	24,900	1	20	123	-3	47
210014	754,081	4,162,999	2016	5	-200	35	1,420	25	30,900	2	21	80	8	50

**TABLE APPENDIX J-1
2016-2017 FREMONT SOIL GEOCHEMISTRY ASSAY RESULTS**

Sample ID	Easting	Northing	Year	Au (ppb)	Ag (ppb)	As (ppm)	Ca (ppm)	Cu (ppm)	Fe (ppm)	Mo (ppm)	Pb (ppm)	S (ppm)	Sb (ppm)	Zn (ppm)
210015	753,375	4,164,810	2016	4	-200	18	2,610	30	27,700	-1	22	80	-3	61
210016	753,376	4,164,907	2016	-3	-200	16	743	24	27,900	-1	17	68	-3	49
210017	753,382	4,164,999	2016	-3	-200	12	1,210	24	26,800	-1	13	55	-3	48
210018	753,379	4,165,100	2016	3	-200	22	874	25	27,810	-1	14	64	3	43
210019	753,380	4,165,201	2016	6	-200	19	1,760	27	24,800	1	21	76	-3	41
210020	753,380	4,165,292	2016	7	200	21	708	16	22,400	1	20	51	-3	35
210021	753,383	4,165,398	2016	21	-200	53	1,240	22	28,500	1	21	64	5	44
210022	753,380	4,165,501	2016	4	-200	24	1,220	14	18,100	1	27	68	-3	35
210023	753,379	4,165,598	2016	82	-200	235	2,870	23	27,100	1	22	93	5	41
210024	753,382	4,165,701	2016	354	200	421	1,680	45	39,400	1	13	44	6	41
210027	753,379	4,165,898	2016	62	300	182	1,120	27	31,800	1	15	68	6	46
210028	753,383	4,165,995	2016	28	300	72	4,560	49	42,110	2	10	124	4	75
210029	753,376	4,166,100	2016	803	300	1140	24,000	24	32,700	-1	5	774	4	57
210030	753,379	4,166,201	2016	21	200	27	2,620	47	27,800	7	16	94	4	233
210031	753,380	4,166,302	2016	5	-200	9	2,340	48	31,900	2	14	82	-3	104
210032	753,378	4,166,401	2016	6	-200	7	3,340	64	44,110	1	11	73	-3	53
210033	753,380	4,166,499	2016	9	200	8	1,740	53	31,400	3	14	43	-3	59
210034	753,380	4,166,599	2016	9	200	11	2,640	47	26,700	2	14	77	-3	83
210035	754,221	4,163,401	2016	27	-200	32	1,160	36	34,300	1	14	34	-3	54
210036	754,225	4,163,300	2016	4	-200	11	1,110	28	27,700	-1	13	46	-3	48
210037	754,208	4,163,200	2016	7	-200	16	2,620	26	24,000	1	32	112	-3	54
210038	754,281	4,163,196	2016	4	-200	19	1,480	36	31,000	1	18	79	-3	54
210039	754,281	4,163,100	2016	4	-200	14	1,590	28	28,410	-1	14	52	-3	45
210040	754,179	4,163,099	2016	63	-200	66	2,480	48	28,400	-1	12	90	4	41
210041	754,182	4,162,901	2016	5	-200	20	1,490	29	28,800	2	25	95	-3	55
210042	754,280	4,162,901	2016	-3	-200	15	1,830	24	26,800	-1	14	81	-3	39
210043	754,281	4,162,797	2016	5	200	12	1,380	27	29,400	1	12	53	-3	41

**TABLE APPENDIX J-1
2016-2017 FREMONT SOIL GEOCHEMISTRY ASSAY RESULTS**

Sample ID	Easting	Northing	Year	Au (ppb)	Ag (ppb)	As (ppm)	Ca (ppm)	Cu (ppm)	Fe (ppm)	Mo (ppm)	Pb (ppm)	S (ppm)	Sb (ppm)	Zn (ppm)
210044	754,181	4,162,801	2016	3	-200	27	716	27	34,400	1	12	59	6	46
210045	754,082	4,162,798	2016	3	-200	14	2,550	31	27,200	2	27	139	-3	55
210046	754,086	4,162,890	2016	-3	-200	28	800	35	39,100	2	22	55	7	52
210047	754,079	4,163,099	2016	4	-200	15	160	22	27,000	2	25	59	-3	41
210048	754,077	4,163,196	2016	6	-200	10	1,680	14	21,400	2	18	82	-3	23
210049	754,089	4,163,295	2016	3	-200	16	264	10	22,600	2	15	49	-3	18
210050	754,082	4,163,401	2016	-3	-200	11	584	15	21,100	1	20	32	-3	32
210051	754,087	4,164,511	2017	188	300	153	172	48	44,800	-1	5	27	4	9
210052	754,075	4,164,595	2017	38	-200	116	2,370	23	43,100	-1	11	120	3	21
210053	754,085	4,164,698	2017	9	-200	29	3,660	44	31,900	-1	4	108	-3	18
210054	754,082	4,164,801	2017	5	-200	9	2,360	50	31,000	-1	8	74	-3	29
210055	754,081	4,164,898	2017	14	-200	4	1,520	38	45,800	-1	7	93	3	27
210056	754,080	4,165,003	2017	11	-200	3	712	44	39,400	-1	3	33	4	17
210057	754,077	4,165,102	2017	5	-200	4	3,210	80	24,900	-1	4	91	-3	33
210058	754,075	4,165,196	2017	6	-200	5	2,710	69	26,400	-1	5	92	-3	33
210059	754,083	4,165,300	2017	8	-200	9	2,590	70	31,300	-1	30	96	-3	27
210060	754,084	4,165,400	2017	5	-200	3	4,240	68	27,400	-1	6	102	-3	33
210061	753,980	4,165,401	2017	7	-200	6	1,000	43	43,000	-1	23	205	5	40
210062	753,979	4,165,500	2017	6	-200	3	1,920	53	29,200	-1	11	122	-3	36
210063	753,983	4,165,598	2017	5	-200	2	2,420	83	26,900	-1	11	76	-3	38
210064	753,979	4,165,698	2017	-3	-200	5	2,580	90	31,700	-1	9	131	-3	40
210065	753,977	4,165,802	2017	7	-200	6	2,710	93	28,310	-1	11	104	-3	31
210066	753,979	4,165,898	2017	6	-200	8	3,150	96	35,200	-1	15	73	-3	35
210067	754,779	4,163,997	2017	8	-200	2	2,950	59	21,500	-1	8	71	-3	33
210068	754,777	4,164,099	2017	3	-200	4	3,200	57	28,600	-1	10	127	-3	45
210069	754,777	4,164,196	2017	5	-200	7	4,880	53	26,100	-1	11	248	-3	56
210070	754,783	4,164,298	2017	24	-200	14	2,720	87	33,900	-1	9	144	-3	52

**TABLE APPENDIX J-1
2016-2017 FREMONT SOIL GEOCHEMISTRY ASSAY RESULTS**

Sample ID	Easting	Northing	Year	Au (ppb)	Ag (ppb)	As (ppm)	Ca (ppm)	Cu (ppm)	Fe (ppm)	Mo (ppm)	Pb (ppm)	S (ppm)	Sb (ppm)	Zn (ppm)
210071	754,781	4,164,398	2017	11	-200	16	3,230	105	36,900	-1	9	117	-3	39
210072	754,773	4,164,499	2017	8	-200	9	3,000	89	31,200	-1	7	106	-3	44
210073	754,771	4,164,604	2017	10	-200	16	4,250	102	46,200	-1	9	52	3	40
210074	754,779	4,164,701	2017	8	-200	5	2,610	89	32,400	-1	6	47	-3	34
210077	754,778	4,164,899	2017	10	-200	8	2,650	101	44,200	-1	9	66	-3	36
210078	754,782	4,164,995	2017	9	-200	9	2,490	92	38,100	-1	12	79	-3	28
210079	754,779	4,165,097	2017	6	-200	8	2,490	77	32,100	-1	14	68	-3	26
210080	754,780	4,165,201	2017	3	-200	4	2,480	71	24,410	-1	5	48	-3	26
210081	754,779	4,165,299	2017	7	-200	5	3,030	76	28,500	-1	5	61	-3	32
210082	754,779	4,165,400	2017	4	-200	4	4,040	64	44,100	-1	9	62	-3	36
210083	754,784	4,165,506	2017	6	-200	9	1,020	44	29,400	2	15	46	-3	54
210084	754,777	4,165,602	2017	9	200	48	922	36	34,500	2	16	85	-3	52
210085	754,781	4,165,701	2017	10	-200	8	1,650	43	27,800	-1	11	70	-3	43
210086	754,781	4,165,795	2017	4	-200	5	1,710	27	32,410	1	12	60	-3	49
210087	755,179	4,163,699	2017	3	-200	2	2,810	49	23,100	-1	5	71	-3	34
210088	755,178	4,163,800	2017	3	-200	2	3,140	61	25,300	-1	10	113	-3	38
210089	755,174	4,163,898	2017	4	-200	3	4,360	72	30,000	-1	9	152	-3	43
210090	755,181	4,163,997	2017	3	-200	5	4,040	61	29,400	-1	13	121	-3	53
210091	755,176	4,164,097	2017	8	-200	4	4,240	73	33,100	-1	9	80	-3	52
210092	755,177	4,164,199	2017	6	-200	3	2,540	85	35,400	-1	7	72	-3	43
210093	755,178	4,164,298	2017	5	-200	4	5,130	105	31,900	-1	5	49	-3	49
210094	755,180	4,164,398	2017	18	-200	12	2,870	93	34,700	-1	8	77	-3	34
210095	755,181	4,164,497	2017	7	-200	5	1,980	95	38,900	-1	8	76	-3	36
210096	755,177	4,164,598	2017	10	-200	4	2,850	69	32,910	-1	8	95	-3	47
210097	755,182	4,164,703	2017	8	-200	6	3,120	94	32,200	-1	6	117	-3	39
210098	755,181	4,164,799	2017	7	-200	7	3,160	95	33,000	-1	6	116	-3	40
210099	755,181	4,164,897	2017	7	-200	5	2,830	79	35,500	-1	8	100	-3	43

**TABLE APPENDIX J-1
2016-2017 FREMONT SOIL GEOCHEMISTRY ASSAY RESULTS**

Sample ID	Easting	Northing	Year	Au (ppb)	Ag (ppb)	As (ppm)	Ca (ppm)	Cu (ppm)	Fe (ppm)	Mo (ppm)	Pb (ppm)	S (ppm)	Sb (ppm)	Zn (ppm)
210100	755,179	4,164,996	2017	12	300	5	3,390	108	35,100	-1	9	100	-3	43
210101	754,985	4,164,801	2017	14	-200	8	2,950	99	44,500	-1	8	110	-3	44
210102	754,986	4,164,903	2017	6	-200	5	3,740	90	32,000	-1	6	85	-3	41
210103	754,981	4,165,006	2017	12	-200	6	3,440	89	36,300	-1	10	137	-3	36
210104	754,980	4,165,100	2017	11	-200	13	3,630	84	39,700	-1	8	90	-3	36
210105	754,979	4,165,199	2017	7	-200	25	4,510	93	34,100	-1	5	140	-3	36
210106	754,985	4,165,296	2017	8	-200	9	3,390	52	34,000	-1	11	109	-3	32
210107	754,982	4,165,400	2017	6	-200	10	2,220	48	37,200	4	14	85	3	63
210108	754,981	4,165,495	2017	6	300	9	2,010	46	31,900	3	15	82	-3	48
210109	754,979	4,165,596	2017	10	-200	10	1,550	37	31,100	1	17	75	-3	58
210110	754,968	4,165,699	2017	8	-200	9	1,560	40	31,700	2	14	51	-3	54
210111	754,982	4,165,798	2017	3	-200	7	4,020	46	35,700	1	10	63	-3	62
210112	755,580	4,163,499	2017	3	-200	2	4,280	76	32,700	-1	7	166	-3	35
210113	755,581	4,163,602	2017	4	-200	4	3,500	58	22,100	-1	6	115	-3	34
210114	755,582	4,163,699	2017	3	-200	-2	2,750	53	21,400	-1	4	74	-3	25
210115	755,577	4,163,796	2017	3	-200	4	3,740	90	27,500	-1	5	80	-3	81
210116	755,578	4,163,896	2017	5	-200	3	3,830	93	42,700	-1	9	91	-3	42
210117	755,580	4,163,999	2017	3	-200	3	2,340	60	33,200	-1	11	84	-3	56
210118	755,582	4,164,101	2017	4	-200	3	3,880	64	32,200	-1	12	96	-3	61
210119	755,587	4,164,202	2017	7	-200	3	10,200	73	33,800	-1	13	371	-3	57
210120	755,579	4,164,305	2017	5	-200	3	4,120	60	27,300	-1	6	123	-3	53
210121	755,579	4,164,398	2017	7	200	5	4,060	87	29,500	-1	48	307	-3	81
210122	755,580	4,164,497	2017	9	-200	4	3,800	64	29,500	-1	14	175	-3	55
210123	755,583	4,164,604	2017	267	-200	4	3,810	74	36,100	-1	9	94	-3	49
210124	755,582	4,164,693	2017	12	-200	4	3,120	58	37,000	-1	11	111	-3	56
210127	755,575	4,164,886	2017	10	-200	6	3,090	64	32,900	-1	9	68	-3	37
210128	755,586	4,164,999	2017	18	-200	12	4,820	87	36,900	2	12	62	-3	123

**TABLE APPENDIX J-1
2016-2017 FREMONT SOIL GEOCHEMISTRY ASSAY RESULTS**

Sample ID	Easting	Northing	Year	Au (ppb)	Ag (ppb)	As (ppm)	Ca (ppm)	Cu (ppm)	Fe (ppm)	Mo (ppm)	Pb (ppm)	S (ppm)	Sb (ppm)	Zn (ppm)
210129	755,580	4,165,096	2017	5	-200	7	2,340	53	32,900	1	10	61	-3	51
210130	755,581	4,165,194	2017	8	-200	7	2,070	50	35,300	-1	11	65	-3	34
210131	755,588	4,165,301	2017	7	-200	6	2,100	36	35,700	2	13	57	-3	99
210132	755,582	4,165,397	2017	4	-200	7	2,500	38	38,700	1	15	75	-3	55
210133	755,780	4,163,501	2017	4	-200	2	3,280	64	25,200	-1	11	90	-3	28
210134	755,778	4,163,598	2017	7	-200	2	3,030	57	22,710	-1	5	69	-3	30
210135	755,775	4,163,695	2017	3	-200	2	3,090	63	23,300	-1	7	76	-3	40
210136	755,780	4,163,799	2017	5	-200	4	2,890	68	29,000	-1	8	59	-3	49
210137	755,782	4,163,898	2017	5	-200	3	3,440	89	35,300	-1	6	55	-3	55
210138	755,784	4,163,999	2017	4	-200	2	3,240	90	34,700	-1	6	60	-3	47
210139	755,782	4,164,100	2017	5	-200	3	4,800	73	35,600	-1	17	140	-3	81
210140	755,776	4,164,196	2017	8	-200	4	3,590	67	32,000	-1	8	83	-3	51
210141	755,774	4,164,298	2017	12	-200	7	4,020	67	33,700	-1	10	99	-3	52
210142	755,781	4,164,401	2017	6	-200	4	4,940	87	32,000	-1	9	117	-3	64
210143	755,781	4,164,499	2017	7	-200	4	4,270	88	31,200	-1	9	77	-3	54
210144	755,781	4,164,598	2017	6	-200	4	3,860	59	26,600	-1	11	120	-3	48
210145	755,783	4,164,705	2017	6	-200	5	3,640	63	29,300	-1	10	100	-3	48
210146	755,776	4,164,799	2017	8	-200	9	3,870	59	29,900	-1	8	111	-3	38
210147	755,778	4,164,901	2017	9	-200	10	2,840	71	33,700	-1	11	121	-3	39
210148	755,781	4,164,996	2017	4	-200	7	4,120	62	36,800	-1	9	152	-3	73
210149	755,776	4,165,097	2017	6	-200	8	1,240	43	33,300	3	15	41	-3	55
210150	755,786	4,165,196	2017	7	300	9	1,560	42	28,900	1	16	46	-3	48
210151	755,075	4,164,901	2017	6	-200	4	6,230	87	31,900	-1	7	191	-3	63
210152	755,083	4,165,001	2017	10	-200	18	2,990	105	34,500	-1	23	111	-3	67
210153	755,078	4,165,100	2017	10	-200	13	3,620	90	31,800	-1	6	108	-3	34
210154	755,075	4,165,200	2017	13	-200	10	3,490	56	31,000	-1	9	110	-3	35
210155	755,086	4,165,300	2017	5	-200	8	1,270	47	31,200	4	13	46	-3	53

**TABLE APPENDIX J-1
2016-2017 FREMONT SOIL GEOCHEMISTRY ASSAY RESULTS**

Sample ID	Easting	Northing	Year	Au (ppb)	Ag (ppb)	As (ppm)	Ca (ppm)	Cu (ppm)	Fe (ppm)	Mo (ppm)	Pb (ppm)	S (ppm)	Sb (ppm)	Zn (ppm)
210156	755,088	4,165,398	2017	4	-200	8	1,230	33	29,300	2	13	56	-3	50
210157	755,081	4,165,498	2017	7	200	8	1,010	41	28,600	2	19	77	-3	49
210158	755,076	4,165,595	2017	6	300	7	1,360	43	36,100	4	11	100	-3	67
210159	755,083	4,165,705	2017	5	-200	8	1,130	37	27,200	3	16	82	-3	56
210160	755,088	4,165,802	2017	12	-200	10	1,430	57	34,500	3	20	95	-3	57
210161	755,277	4,163,599	2017	4	-200	-2	3,060	51	21,200	-1	5	54	-3	34
210162	755,280	4,163,700	2017	14	-200	-2	2,740	62	26,600	-1	6	77	-3	32
210163	755,282	4,163,800	2017	5	-200	3	3,050	55	25,100	-1	7	71	-3	30
210164	755,280	4,163,900	2017	7	-200	4	3,810	67	26,800	-1	8	163	-3	40
210165	755,280	4,163,999	2017	9	-200	3	3,530	75	37,600	-1	12	98	-3	43
210166	755,279	4,164,099	2017	3	-200	4	3,800	79	39,400	-1	8	103	-3	49
210167	755,280	4,164,199	2017	5	-200	4	3,580	89	33,100	-1	9	80	-3	103
210168	755,281	4,164,300	2017	67	-200	23	3,700	117	35,200	-1	9	120	-3	59
210169	755,279	4,164,398	2017	14	-200	8	3,480	103	30,900	-1	7	132	-3	53
210170	755,286	4,164,497	2017	6	-200	4	3,270	91	34,400	-1	10	120	-3	47
210171	755,280	4,164,598	2017	15	-200	5	3,540	102	38,600	-1	9	117	-3	43
210172	755,282	4,164,699	2017	7	-200	5	3,050	98	41,600	-1	7	104	-3	48
210173	755,287	4,164,799	2017	3	-200	5	3,630	81	46,210	-1	8	166	-3	52
210174	755,281	4,164,899	2017	7	-200	6	4,320	93	44,300	-1	7	207	-3	39
210177	755,282	4,165,097	2017	14	-200	15	1,660	63	36,500	2	11	63	-3	65
210178	755,281	4,165,196	2017	7	300	10	938	58	31,300	2	15	64	-3	54
210179	755,306	4,165,313	2017	17	300	6	1,150	50	28,600	-1	14	53	-3	69
210180	755,276	4,165,399	2017	5	-200	4	2,060	23	31,900	-1	18	100	-3	77
210181	755,282	4,165,496	2017	3	300	12	1,730	52	40,400	5	39	255	3	58
210182	755,289	4,165,602	2017	3	-200	5	1,750	26	31,100	-1	18	96	-3	51
210183	755,880	4,163,503	2017	4	-200	3	5,130	75	24,600	-1	10	159	-3	45
210184	755,286	4,165,692	2017	4	-200	7	2,660	22	26,200	6	21	106	-3	112

**TABLE APPENDIX J-1
2016-2017 FREMONT SOIL GEOCHEMISTRY ASSAY RESULTS**

Sample ID	Easting	Northing	Year	Au (ppb)	Ag (ppb)	As (ppm)	Ca (ppm)	Cu (ppm)	Fe (ppm)	Mo (ppm)	Pb (ppm)	S (ppm)	Sb (ppm)	Zn (ppm)
210185	755,879	4,163,600	2017	4	-200	3	2,540	60	26,500	-1	8	112	-3	35
210186	755,879	4,163,700	2017	4	-200	3	4,020	54	23,400	-1	7	84	-3	35
210187	755,878	4,163,795	2017	11	-200	3	2,820	49	22,400	-1	7	86	-3	36
210188	755,885	4,165,104	2017	4	-200	7	2,920	33	30,400	2	17	89	-3	66
210189	755,876	4,165,193	2017	5	-200	6	1,940	39	28,200	1	14	59	-3	54
210190	755,877	4,165,294	2017	9	-200	7	2,080	55	28,800	-1	15	55	-3	62
210191	755,879	4,165,392	2017	3	-200	7	3,520	66	36,300	-1	14	87	-3	52
210192	756,486	4,165,303	2017	-3	-200	6	2,330	32	26,700	2	14	81	-3	95
210193	756,479	4,165,199	2017	-3	-200	4	1,310	22	27,200	-1	13	63	-3	55
210194	756,484	4,165,108	2017	4	-200	6	1,800	32	32,100	1	27	65	-3	59
210195	756,379	4,163,497	2017	3	-200	3	2,380	54	29,200	-1	9	62	-3	36
210196	756,381	4,163,601	2017	5	-200	2	4,370	47	30,600	-1	10	110	-3	59
210197	756,380	4,163,699	2017	3	-200	3	2,870	65	41,800	-1	9	71	-3	48
210198	756,383	4,163,797	2017	10	-200	3	2,890	61	36,400	-1	8	66	-3	57
210199	756,381	4,163,902	2017	74	-200	5	3,430	58	29,100	-1	10	123	-3	50
210200	756,381	4,164,002	2017	12	-200	4	2,310	61	31,700	-1	8	75	-3	49
210201	755,984	4,163,500	2017	4	-200	3	2,750	64	22,900	1	8	125	-3	38
210202	755,978	4,163,600	2017	3	-200	2	3,170	68	25,500	-1	6	74	-3	40
210203	755,979	4,163,700	2017	38	-200	3	2,660	72	31,800	-1	6	67	-3	56
210204	755,983	4,163,800	2017	4	-200	3	2,220	61	28,100	-1	6	51	-3	36
210205	755,979	4,163,897	2017	3	-200	2	4,050	102	38,600	-1	7	63	-3	52
210206	755,979	4,164,000	2017	4	-200	-2	2,320	70	31,500	-1	6	75	-3	49
210207	755,976	4,164,100	2017	3	-200	4	3,460	63	33,200	-1	8	107	-3	43
210208	755,981	4,164,199	2017	9	-200	5	3,540	75	36,700	-1	9	109	-3	60
210209	755,986	4,164,303	2017	4	-200	2	3,990	68	31,100	-1	9	123	-3	58
210210	755,982	4,164,401	2017	8	-200	5	6,380	93	50,100	-1	14	244	-3	107
210211	755,979	4,164,496	2017	5	-200	3	2,630	56	33,200	-1	12	85	-3	81

**TABLE APPENDIX J-1
2016-2017 FREMONT SOIL GEOCHEMISTRY ASSAY RESULTS**

Sample ID	Easting	Northing	Year	Au (ppb)	Ag (ppb)	As (ppm)	Ca (ppm)	Cu (ppm)	Fe (ppm)	Mo (ppm)	Pb (ppm)	S (ppm)	Sb (ppm)	Zn (ppm)
210212	755,974	4,164,599	2017	6	-200	4	4,680	106	44,300	-1	10	79	-3	122
210213	755,976	4,164,697	2017	12	-200	12	4,920	88	37,900	-1	9	145	-3	91
210214	756,019	4,164,821	2017	829	400	636	5,150	128	46,500	-1	6	47	5	68
210215	756,025	4,164,894	2017	22	-200	68	3,780	100	38,200	5	13	99	5	208
210216	755,982	4,165,006	2017	4	-200	9	1,160	36	29,900	2	17	37	-3	82
210217	755,974	4,165,104	2017	6	-200	9	1,140	47	29,300	7	12	49	3	48
210218	755,980	4,165,202	2017	13	-200	4	2,060	41	25,600	-1	13	19	-3	68
210219	755,981	4,165,302	2017	11	-200	6	1,090	45	31,100	1	15	43	-3	60
210220	755,978	4,165,401	2017	-3	-200	7	1,770	45	32,900	1	13	41	-3	66
210221	756,733	4,165,307	2017	5	-200	8	730	44	27,900	3	14	67	-3	66
210222	756,748	4,165,202	2017	-3	-200	6	3,180	48	33,700	2	15	91	-3	113
210223	756,748	4,165,135	2017	3	-200	11	1,580	42	32,700	3	13	52	-3	120
210224	756,680	4,165,118	2017	-3	-200	6	922	28	30,000	2	12	44	-3	74
210227	756,281	4,163,599	2017	7	-200	4	4,000	69	40,900	-1	11	119	-3	57
210228	756,277	4,163,703	2017	3	-200	4	3,200	77	46,700	-1	10	93	-3	62
210229	756,281	4,163,800	2017	4	200	5	2,270	69	55,400	1	12	112	-3	42
210230	756,279	4,163,901	2017	6	-200	4	2,180	56	40,000	-1	10	76	-3	45
210231	756,280	4,164,003	2017	5	-200	6	2,380	66	41,900	-1	14	99	-3	79
210232	756,278	4,164,098	2017	6	-200	10	2,770	99	53,310	-1	16	113	-3	122
210233	756,275	4,164,203	2017	3	200	13	2,570	96	49,210	-1	44	88	-3	293
210234	756,276	4,164,296	2017	-3	-200	8	2,960	80	44,800	-1	16	138	-3	122
210235	756,279	4,164,400	2017	-3	-200	11	3,280	81	45,300	-1	13	133	-3	127
210236	756,275	4,164,499	2017	5	-200	11	2,590	81	46,200	-1	13	80	-3	139
210237	756,277	4,164,599	2017	9	-200	8	3,410	105	49,800	-1	8	146	-3	64
210238	756,278	4,164,689	2017	4	-200	10	1,880	66	29,700	-1	9	139	-3	70
210239	756,274	4,164,806	2017	5	-200	19	3,800	42	28,000	2	11	110	-3	100
210240	756,280	4,164,892	2017	10	-200	7	4,600	37	28,900	-1	14	148	-3	94

**TABLE APPENDIX J-1
2016-2017 FREMONT SOIL GEOCHEMISTRY ASSAY RESULTS**

Sample ID	Easting	Northing	Year	Au (ppb)	Ag (ppb)	As (ppm)	Ca (ppm)	Cu (ppm)	Fe (ppm)	Mo (ppm)	Pb (ppm)	S (ppm)	Sb (ppm)	Zn (ppm)
210241	756,277	4,164,993	2017	6	200	15	3,140	106	31,100	-1	73	505	-3	133
210242	756,285	4,165,099	2017	3	200	5	1,350	30	28,100	1	27	133	-3	48
210243	756,280	4,165,196	2017	5	200	8	2,900	57	29,300	2	19	97	-3	77
210244	756,282	4,165,298	2017	-3	-200	7	1,670	44	27,710	2	16	88	-3	77
210245	756,282	4,165,392	2017	3	-200	5	2,770	53	28,300	1	12	61	-3	57
210247	755,381	4,163,501	2017	4	-200	-2	2,260	59	26,100	-1	6	62	-3	23
210248	755,278	4,163,501	2017	-3	-200	3	3,250	59	26,600	-1	10	108	-3	29
210249	755,180	4,163,500	2017	-3	-200	-2	2,850	50	19,700	-1	5	51	-3	21
210250	755,180	4,163,600	2017	-3	-200	2	4,450	64	23,100	-1	7	104	-3	28
210251	755,185	4,165,101	2017	8	200	37	7,280	82	25,400	-1	9	228	-3	40
210252	755,185	4,165,200	2017	11	-200	14	6,230	93	27,400	-1	10	194	-3	44
210253	755,183	4,165,295	2017	5	900	21	3,540	56	25,700	4	13	100	-3	115
210254	755,182	4,165,395	2017	-3	-200	9	3,720	33	27,800	1	16	133	-3	59
210255	755,184	4,165,497	2017	4	-200	7	3,240	31	27,100	1	14	102	-3	51
210256	755,176	4,165,598	2017	-3	-200	5	1,410	17	22,000	1	15	44	-3	33
210257	755,166	4,165,704	2017	-3	-200	9	2,910	42	28,600	4	39	83	-3	87
210258	755,181	4,165,796	2017	3	-200	12	1,440	26	24,100	3	16	105	-3	58
210259	755,378	4,163,601	2017	3	-200	4	2,480	51	19,400	-1	8	71	-3	30
210260	755,384	4,163,699	2017	4	-200	3	2,870	54	23,600	-1	7	84	-3	27
210261	755,378	4,163,800	2017	6	-200	3	2,550	60	22,600	-1	6	50	-3	28
210262	755,380	4,163,900	2017	7	-200	7	3,170	89	29,300	-1	9	80	-3	53
210263	755,381	4,164,003	2017	5	-200	3	3,670	64	34,700	-1	12	89	-3	51
210264	755,380	4,164,100	2017	-3	-200	4	3,960	57	31,200	-1	8	140	-3	51
210265	755,381	4,164,197	2017	5	-200	4	3,130	52	31,300	-1	11	126	-3	41
210266	755,380	4,164,299	2017	5	-200	5	2,450	61	28,600	-1	9	74	-3	44
210267	755,379	4,164,402	2017	7	-200	5	2,150	78	27,600	-1	7	54	-3	44
210268	755,379	4,164,496	2017	5	-200	5	2,060	97	34,500	-1	8	33	-3	40

**TABLE APPENDIX J-1
2016-2017 FREMONT SOIL GEOCHEMISTRY ASSAY RESULTS**

Sample ID	Easting	Northing	Year	Au (ppb)	Ag (ppb)	As (ppm)	Ca (ppm)	Cu (ppm)	Fe (ppm)	Mo (ppm)	Pb (ppm)	S (ppm)	Sb (ppm)	Zn (ppm)
210269	755,381	4,164,602	2017	8	-200	6	4,120	81	33,700	-1	11	100	-3	38
210270	755,378	4,164,703	2017	4	-200	4	3,140	80	41,500	-1	9	78	-3	48
210271	755,379	4,164,797	2017	7	-200	5	3,070	70	41,400	-1	8	95	-3	39
210272	755,380	4,164,898	2017	3	-200	5	3,710	84	43,400	-1	8	95	-3	45
210273	755,384	4,164,997	2017	7	-200	12	3,080	73	38,000	-1	9	107	-3	39
210274	755,382	4,165,097	2017	13	-200	10	1,630	56	35,400	2	12	65	-3	52
210277	755,389	4,165,302	2017	5	300	7	1,150	37	24,110	1	15	36	-3	49
210278	755,385	4,165,403	2017	6	300	8	1,260	48	28,600	4	14	68	-3	53
210279	755,374	4,165,500	2017	12	-200	262	1,540	26	32,300	2	14	71	5	51
210280	755,377	4,165,601	2017	6	-200	11	1,370	50	31,400	5	17	53	-3	141
210281	755,382	4,165,699	2017	3	-200	4	1,060	26	24,700	2	12	33	-3	82
210282	755,479	4,165,397	2017	5	-200	8	2,280	51	31,500	1	11	96	-3	38
210283	755,679	4,163,500	2017	3	-200	-2	3,730	54	19,800	-1	8	102	-3	34
210284	755,683	4,163,604	2017	3	-200	2	3,520	45	21,500	-1	6	128	-3	30
210285	753,978	4,163,609	2017	7	-200	22	1,640	16	24,110	1	22	72	-3	34
210286	753,977	4,163,502	2017	4	-200	22	2,100	19	25,200	1	21	80	-3	40
210287	753,980	4,163,406	2017	4	-200	12	2,290	31	30,900	1	15	85	-3	52
210288	753,981	4,163,302	2017	-3	-200	13	940	14	20,800	2	26	72	-3	32
210289	753,981	4,163,199	2017	-3	-200	18	2,550	18	26,610	2	26	94	-3	45
210290	753,980	4,163,104	2017	5	-200	25	503	38	36,300	2	20	39	5	53
210291	753,983	4,163,003	2017	-3	-200	13	1,290	39	33,400	1	25	45	-3	65
210292	753,986	4,162,899	2017	3	-200	19	1,770	45	35,400	2	26	63	-3	74
210293	753,980	4,162,810	2017	3	-200	12	1,690	31	29,300	1	18	47	-3	48
210294	754,879	4,163,501	2017	5	-200	2	3,260	67	28,400	-1	7	82	-3	35
210295	754,776	4,163,504	2017	6	-200	2	3,150	53	22,800	-1	7	65	-3	29
210296	754,778	4,163,601	2017	3	-200	-2	3,970	69	25,200	-1	6	86	-3	33
210297	754,778	4,163,699	2017	3	-200	-2	4,080	64	25,000	-1	7	113	-3	43

**TABLE APPENDIX J-1
2016-2017 FREMONT SOIL GEOCHEMISTRY ASSAY RESULTS**

Sample ID	Easting	Northing	Year	Au (ppb)	Ag (ppb)	As (ppm)	Ca (ppm)	Cu (ppm)	Fe (ppm)	Mo (ppm)	Pb (ppm)	S (ppm)	Sb (ppm)	Zn (ppm)
210298	754,779	4,163,799	2017	9	-200	3	2,970	64	28,900	-1	7	119	-3	30
210299	754,780	4,163,899	2017	4	-200	3	2,980	71	19,900	-1	10	63	-3	31
210300	754,685	4,163,497	2017	-3	-200	3	3,780	60	27,100	-1	8	112	-3	34
210301	755,684	4,163,701	2017	4	-200	2	2,790	49	20,700	-1	6	72	-3	30
210302	755,680	4,163,801	2017	5	200	5	2,680	82	26,200	-1	27	180	-3	82
210303	755,681	4,163,901	2017	4	-200	2	3,520	70	30,800	-1	12	133	-3	51
210304	755,680	4,163,998	2017	4	-200	3	4,040	65	31,900	-1	9	125	-3	55
210305	755,681	4,164,099	2017	-3	-200	3	3,660	73	34,700	-1	9	102	-3	70
210306	755,688	4,164,197	2017	4	-200	2	4,330	106	36,200	-1	5	59	-3	63
210307	755,680	4,164,299	2017	21	-200	2	5,920	74	31,300	-1	10	200	-3	58
210308	755,676	4,164,401	2017	5	-200	3	5,420	82	32,400	-1	8	164	-3	70
210309	755,679	4,164,497	2017	7	-200	3	4,420	77	34,400	-1	8	126	-3	71
210310	755,680	4,164,596	2017	5	300	4	4,690	73	40,400	-1	10	129	-3	63
210311	755,682	4,164,702	2017	8	200	4	3,950	59	30,900	-1	11	116	-3	56
210312	755,675	4,164,799	2017	10	-200	11	5,130	62	37,500	-1	9	113	-3	48
210313	755,680	4,164,898	2017	32	-200	16	4,860	111	46,100	-1	5	88	-3	60
210314	755,676	4,164,997	2017	76	200	9	1,820	49	29,300	4	18	89	-3	174
210315	755,672	4,165,102	2017	3	-200	6	1,970	61	36,200	2	12	42	-3	76
210316	755,679	4,165,194	2017	4	200	5	2,460	35	23,400	-1	14	135	-3	77
210317	755,680	4,165,295	2017	-3	-200	5	1,640	31	28,300	1	14	68	-3	70
210318	755,681	4,165,394	2017	-3	-200	4	3,620	36	31,300	-1	9	50	-3	39
210319	756,678	4,165,302	2017	5	200	11	2,820	47	26,700	2	20	124	-3	80
210320	756,681	4,165,203	2017	4	-200	10	1,450	41	34,000	3	17	66	4	174
210321	756,180	4,163,501	2017	5	-200	2	3,390	80	25,100	-1	4	72	-3	49
210322	756,181	4,163,600	2017	13	-200	2	3,780	68	30,000	-1	10	91	-3	51
210323	756,180	4,163,705	2017	-3	-200	3	3,220	67	33,500	-1	8	101	-3	53
210324	756,178	4,163,800	2017	12	-200	3	3,610	49	31,800	-1	10	98	-3	53

**TABLE APPENDIX J-1
2016-2017 FREMONT SOIL GEOCHEMISTRY ASSAY RESULTS**

Sample ID	Easting	Northing	Year	Au (ppb)	Ag (ppb)	As (ppm)	Ca (ppm)	Cu (ppm)	Fe (ppm)	Mo (ppm)	Pb (ppm)	S (ppm)	Sb (ppm)	Zn (ppm)
210327	756,176	4,163,998	2017	6	-200	4	4,840	55	31,900	-1	10	143	-3	40
210328	756,180	4,164,099	2017	-3	-200	3	3,960	74	37,400	-1	11	120	-3	77
210329	756,184	4,164,201	2017	9	-200	4	4,080	99	37,700	-1	11	123	-3	92
210330	756,180	4,164,303	2017	10	200	4	2,830	123	49,900	-1	15	136	-3	144
210331	756,181	4,164,400	2017	4	200	10	3,180	95	38,800	-1	20	175	-3	129
210332	756,173	4,164,496	2017	17	-200	13	2,920	132	61,200	-1	7	66	-3	103
210333	756,178	4,164,599	2017	8	-200	8	3,100	86	48,700	-1	8	95	-3	82
210334	756,179	4,164,697	2017	7	-200	23	3,950	76	34,500	-1	9	139	-3	66
210335	756,182	4,164,797	2017	9	-200	8	1,950	60	40,100	6	11	103	-3	103
210336	756,172	4,164,901	2017	4	-200	9	1,200	32	30,700	2	16	39	-3	57
210337	756,182	4,164,990	2017	5	-200	7	1,300	46	29,000	1	16	37	-3	54
210338	756,180	4,165,095	2017	10	-200	6	2,180	53	34,700	1	13	67	-3	78
210339	756,183	4,165,193	2017	3	-200	8	1,510	39	29,800	-1	17	54	-3	53
210340	756,184	4,165,297	2017	5	-200	18	2,040	43	28,900	2	16	73	-3	98
210341	756,181	4,165,402	2017	-3	-200	10	1,190	32	34,500	2	15	27	-3	89
210342	753,989	4,164,207	2017	1,040	200	289	2,960	54	38,300	2	14	82	5	79
210343	753,986	4,164,098	2017	49	-200	50	3,310	35	33,600	1	17	141	-3	64
210344	753,976	4,163,989	2017	5	-200	24	1,140	27	30,100	1	11	52	-3	53
210345	753,984	4,163,902	2017	18	-200	63	840	34	31,600	2	13	41	3	54
210346	753,974	4,163,789	2017	5	-200	13	933	12	18,700	2	19	34	-3	26
210347	753,985	4,163,700	2017	11	-200	19	1,340	39	30,900	1	12	45	-3	45
210348	754,082	4,163,704	2017	1,130	-200	61	2,400	47	31,100	-1	13	95	-3	45
210349	754,078	4,163,801	2017	16	-200	6	2,450	63	28,000	-1	10	92	-3	37
210350	754,081	4,163,906	2017	27	-200	86	1,520	37	26,300	1	35	69	3	58
210351	755,784	4,165,296	2017	14	-200	10	964	42	33,400	2	17	65	-3	59
210352	755,781	4,165,393	2017	-3	-200	6	3,170	71	37,800	-1	9	51	-3	61
210353	756,573	4,165,302	2017	9	-200	75	2,470	70	30,100	4	19	74	3	95

**TABLE APPENDIX J-1
2016-2017 FREMONT SOIL GEOCHEMISTRY ASSAY RESULTS**

Sample ID	Easting	Northing	Year	Au (ppb)	Ag (ppb)	As (ppm)	Ca (ppm)	Cu (ppm)	Fe (ppm)	Mo (ppm)	Pb (ppm)	S (ppm)	Sb (ppm)	Zn (ppm)
210354	756,581	4,165,203	2017	3	-200	5	1,260	21	23,700	2	12	52	-3	78
210355	756,589	4,165,129	2017	3	-200	8	991	33	27,100	2	14	61	-3	60
210356	756,079	4,163,499	2017	5	-200	3	3,300	102	36,600	-1	8	80	-3	43
210357	756,078	4,163,600	2017	5	-200	2	2,240	64	26,300	-1	7	57	-3	40
210358	756,079	4,163,699	2017	3	-200	3	4,100	80	35,900	-1	9	79	-3	46
210359	756,082	4,163,802	2017	9	-200	4	2,700	68	37,900	-1	8	72	-3	38
210360	756,083	4,163,903	2017	6	-200	3	1,690	68	39,200	-1	8	78	-3	44
210361	756,084	4,164,003	2017	4	-200	4	2,670	68	38,700	-1	10	89	-3	51
210362	756,089	4,164,103	2017	8	300	6	2,430	90	45,400	-1	65	349	-3	104
210363	756,082	4,164,196	2017	7	-200	5	3,770	89	43,900	-1	21	161	-3	101
210364	756,080	4,164,297	2017	5	-200	5	3,970	77	39,700	-1	18	119	-3	109
210365	756,087	4,164,401	2017	12	-200	5	2,900	86	45,900	-1	15	85	-3	106
210366	756,079	4,164,495	2017	5	-200	4	3,790	63	36,200	-1	17	144	-3	91
210367	756,079	4,164,595	2017	6	-200	7	4,410	107	51,700	-1	13	74	-3	106
210368	756,086	4,164,701	2017	8	-200	10	5,320	98	45,400	-1	6	126	-3	75
210369	756,088	4,164,804	2017	20	-200	26	2,310	75	47,500	-1	9	121	-3	80
210370	756,082	4,164,895	2017	5	-200	14	1,900	48	36,000	6	16	78	3	115
210371	756,095	4,164,994	2017	6	-200	9	1,730	65	39,700	2	17	60	-3	89
210372	756,081	4,165,094	2017	4	-200	8	2,940	38	32,800	1	16	111	-3	79
210373	756,085	4,165,202	2017	7	200	7	1,620	48	29,100	-1	16	57	-3	63
210374	756,072	4,165,303	2017	6	-200	7	965	50	28,000	3	17	47	-3	63
210377	756,092	4,165,506	2017	4	-200	7	1,310	35	31,100	2	14	45	-3	74
210378	753,885	4,163,899	2017	17	-200	16	1,150	44	31,700	2	23	46	-3	70
210379	753,883	4,164,002	2017	8	-200	25	859	45	33,600	2	27	58	5	80
210380	753,876	4,164,100	2017	5	200	15	2,580	17	20,300	1	23	170	-3	47
210381	753,881	4,164,204	2017	90	-200	120	1,420	35	39,200	-1	16	50	4	64
210382	753,880	4,163,782	2017	3	-200	14	570	25	32,300	2	17	47	-3	42

**TABLE APPENDIX J-1
2016-2017 FREMONT SOIL GEOCHEMISTRY ASSAY RESULTS**

Sample ID	Easting	Northing	Year	Au (ppb)	Ag (ppb)	As (ppm)	Ca (ppm)	Cu (ppm)	Fe (ppm)	Mo (ppm)	Pb (ppm)	S (ppm)	Sb (ppm)	Zn (ppm)
210383	753,871	4,163,703	2017	3	-200	13	502	30	33,400	2	18	58	-3	62
210384	753,884	4,163,603	2017	-3	-200	8	968	8	11,400	1	18	37	-3	25
210385	753,877	4,163,507	2017	3	-200	12	1,120	8	20,510	1	22	62	-3	23
210386	753,884	4,163,408	2017	-3	-200	12	1,490	29	27,900	1	14	55	-3	46
210387	753,880	4,163,295	2017	6	-200	21	2,580	36	35,600	1	17	105	4	63
210388	753,881	4,163,204	2017	9	-200	21	1,080	41	39,200	2	22	59	-3	56
210389	753,891	4,163,099	2017	6	-200	13	1,520	48	32,000	2	18	83	-3	64
210390	753,885	4,163,005	2017	5	-200	16	1,070	45	33,500	2	22	62	-3	73
210391	753,887	4,162,898	2017	-3	-200	15	4,370	26	32,800	1	16	123	-3	67
210392	753,885	4,162,803	2017	4	-200	14	2,700	30	30,200	1	21	140	-3	65
210393	755,079	4,163,499	2017	8	-200	3	3,320	61	21,700	-1	6	82	-3	32
210394	755,078	4,163,598	2017	3	-200	2	4,750	57	21,310	-1	8	109	-3	36
210395	755,077	4,163,699	2017	5	-200	3	3,490	76	29,500	-1	7	145	-3	30
210396	754,982	4,163,499	2017	5	-200	3	3,260	61	24,100	-1	7	84	-3	35
210397	754,981	4,163,601	2017	-3	-200	3	2,690	63	25,900	-1	5	73	-3	34
210398	754,979	4,163,700	2017	3	-200	2	3,230	64	27,500	-1	8	111	-3	27
210399	754,882	4,163,700	2017	4	-200	3	3,300	72	26,400	-1	8	91	-3	33
210400	754,882	4,163,601	2017	3	-200	3	2,990	67	24,800	-1	6	70	-3	33
210401	755,879	4,163,900	2017	6	-200	2	2,940	71	32,300	-1	9	73	-3	44
210402	755,879	4,164,002	2017	6	-200	3	3,520	59	29,500	-1	11	105	-3	50
210403	755,879	4,164,100	2017	6	-200	4	4,090	63	36,200	-1	13	140	-3	48
210404	755,872	4,164,194	2017	5	-200	3	3,780	61	30,400	-1	8	95	-3	47
210405	755,878	4,164,298	2017	5	-200	3	4,420	79	35,100	-1	10	123	-3	59
210406	755,881	4,164,408	2017	7	-200	5	4,070	74	31,400	-1	11	97	-3	61
210407	755,878	4,164,494	2017	82	-200	79	4,320	85	40,300	-1	9	81	-3	76
210408	755,880	4,164,599	2017	9	-200	5	2,730	71	33,700	-1	8	53	-3	57
210409	755,876	4,164,702	2017	6	-200	6	4,460	76	33,700	-1	9	101	-3	61

**TABLE APPENDIX J-1
2016-2017 FREMONT SOIL GEOCHEMISTRY ASSAY RESULTS**

Sample ID	Easting	Northing	Year	Au (ppb)	Ag (ppb)	As (ppm)	Ca (ppm)	Cu (ppm)	Fe (ppm)	Mo (ppm)	Pb (ppm)	S (ppm)	Sb (ppm)	Zn (ppm)
210410	755,886	4,164,801	2017	6	-200	6	6,340	82	34,300	-1	9	124	-3	64
210411	755,885	4,164,895	2017	6	-200	6	3,150	79	37,300	-1	6	89	-3	64
210412	755,887	4,165,001	2017	3	200	9	1,620	34	29,600	3	16	76	-3	101
210413	756,377	4,164,098	2017	13	-200	3	3,950	97	42,600	-1	40	82	-3	108
210414	756,378	4,164,203	2017	7	-200	11	2,940	93	48,300	-1	33	96	-3	166
210415	756,381	4,164,313	2017	5	-200	9	3,840	101	46,100	-1	13	68	-3	60
210416	756,385	4,164,396	2017	10	-200	45	4,270	85	39,700	-1	32	133	-3	170
210417	756,380	4,164,498	2017	25	-200	11	2,990	104	52,700	-1	14	84	-3	120
210418	756,377	4,164,596	2017	42	-200	19	4,120	99	47,500	-1	10	176	-3	86
210419	756,394	4,164,705	2017	12	-200	23	1,700	86	45,800	3	11	53	3	102
210420	756,385	4,164,796	2017	7	-200	9	3,020	43	32,010	2	13	125	-3	119
210421	756,374	4,164,897	2017	12	200	7	1,570	70	37,000	1	17	47	-3	78
210422	756,377	4,165,000	2017	8	300	8	1,850	66	27,800	1	46	248	-3	86
210423	756,379	4,165,100	2017	5	-200	6	1,990	35	26,300	1	26	120	-3	56
210424	756,380	4,165,199	2017	7	-200	6	2,500	40	29,100	1	19	96	-3	52
210427	754,481	4,163,700	2017	3	300	6	2,890	110	26,600	-1	14	113	-3	38
210428	754,480	4,163,601	2017	3	-200	3	1,040	31	55,100	-1	5	73	-3	25
210429	754,474	4,163,501	2017	42	-200	298	1,550	46	37,600	-1	5	32	13	18
210430	754,381	4,163,503	2017	27	-200	110	1,590	33	32,600	2	20	55	5	54
210431	754,379	4,163,600	2017	52	-200	143	1,240	31	37,000	-1	10	45	7	26
210432	754,387	4,163,704	2017	4	-200	11	1,450	42	35,600	-1	6	62	-3	32
210433	754,381	4,163,798	2017	11	-200	5	3,390	76	23,300	-1	7	92	-3	35
210434	754,380	4,163,900	2017	5	-200	17	2,700	64	30,100	-1	6	67	-3	30
210435	754,381	4,164,004	2017	5	-200	5	2,530	68	27,200	-1	8	92	-3	29
210436	754,276	4,163,991	2017	32	-200	8	3,270	59	28,710	-1	10	121	-3	39
210437	754,280	4,163,902	2017	33	-200	9	3,380	66	38,000	-1	14	125	-3	38
210438	754,281	4,163,801	2017	15	-200	33	2,910	58	28,000	-1	10	104	-3	32

**TABLE APPENDIX J-1
2016-2017 FREMONT SOIL GEOCHEMISTRY ASSAY RESULTS**

Sample ID	Easting	Northing	Year	Au (ppb)	Ag (ppb)	As (ppm)	Ca (ppm)	Cu (ppm)	Fe (ppm)	Mo (ppm)	Pb (ppm)	S (ppm)	Sb (ppm)	Zn (ppm)
210439	754,278	4,163,699	2017	9	-200	12	2,480	38	33,600	1	16	79	-3	33
210440	754,287	4,163,606	2017	93	-200	59	1,240	34	24,000	2	23	103	3	96
210441	754,279	4,163,498	2017	28	-200	50	1,310	30	26,700	-1	13	43	-3	43
210442	754,194	4,163,502	2017	36	-200	35	1,520	35	31,310	2	17	79	-3	56
210443	754,184	4,163,601	2017	16	-200	21	1,720	25	28,200	1	17	91	-3	43
210444	754,182	4,163,698	2017	34	-200	82	1,210	31	31,400	1	13	62	-3	43
210445	754,175	4,163,800	2017	8	-200	10	1,510	52	32,400	-1	10	50	-3	31
210446	754,180	4,163,896	2017	12	-200	50	2,380	68	29,000	-1	12	87	-3	40
210447	754,174	4,164,001	2017	112,491	16,100	662	1,910	173	58,700	1	9	73	22	136
210448	754,084	4,163,504	2017	14	-200	19	1,120	25	26,100	2	19	44	-3	39
210449	754,088	4,163,600	2017	13	-200	12	1,180	9	17,400	2	27	109	-3	26
210451	754,679	4,163,599	2017	4	-200	2	3,410	78	21,500	-1	4	57	-3	31
210452	754,679	4,163,696	2017	4	-200	2	2,730	59	23,400	-1	4	57	-3	28
210453	754,678	4,163,799	2017	49	-200	5	2,770	68	31,000	-1	7	78	-3	30
210454	754,678	4,163,899	2017	4	-200	2	3,640	75	22,900	-1	4	63	-3	32
210455	754,578	4,163,498	2017	6	-200	4	2,550	66	23,610	-1	4	54	-3	35
210456	754,580	4,163,598	2017	9	-200	5	3,720	86	28,500	-1	4	61	-3	34
210457	754,578	4,163,701	2017	3	-200	3	2,260	70	32,400	-1	7	56	-3	32
210458	754,577	4,163,797	2017	21	-200	5	2,950	110	36,800	-1	7	78	-3	34
210459	754,579	4,163,902	2017	3	-200	3	3,110	74	27,410	-1	6	64	-3	27
210460	754,581	4,164,001	2017	4	-200	4	2,940	54	33,300	-1	9	83	-3	32
210461	754,480	4,163,999	2017	6	-200	5	2,000	62	35,500	-1	9	61	-3	32
210462	754,478	4,163,900	2017	7	-200	5	2,410	84	26,500	-1	6	65	-3	38
210463	754,480	4,163,801	2017	5	-200	4	2,240	62	29,300	-1	7	69	-3	38

Source: Stratabound (2022)

APPENDIX K SURFACE TRENCH ASSAYS

TABLE APPENDIX K-1 QUEEN SPECIMEN 2022 TRENCH ASSAYS						
Trench ID	Sample ID	From (ft)	To (ft)	Length (ft)	Length (m)	Au (g/t)
QS-TR-22-001	418303	5	10	5	1.5	0.109
QS-TR-22-001	418304	10	15	5	1.5	0.094
QS-TR-22-001	418305	15	20	5	1.5	0.182
QS-TR-22-001	418306	20	25	5	1.5	1.300
QS-TR-22-001	418307	25	30	5	1.5	0.228
QS-TR-22-001	418308	30	35	5	1.5	1.270
QS-TR-22-001	418309	35	40	5	1.5	0.937
QS-TR-22-001	418310	40	45	5	1.5	0.660
QS-TR-22-001	418311	45	50	5	1.5	0.149
QS-TR-22-001	418312	50	55	5	1.5	0.135
QS-TR-22-001	418313	55	60	5	1.5	0.162
QS-TR-22-001	418314	60	65	5	1.5	0.307
QS-TR-22-001	418315	65	70	5	1.5	0.517
QS-TR-22-001	418316	70	75	5	1.5	0.521
QS-TR-22-001	418317	75	80	5	1.5	1.130
QS-TR-22-001	418318	80	85	5	1.5	0.244
QS-TR-22-001	418319	85	90	5	1.5	0.821
QS-TR-22-001	418320	90	95	5	1.5	0.348
QS-TR-22-001	418321	95	100	5	1.5	0.247
QS-TR-22-001	418323	100	105	5	1.5	0.083
QS-TR-22-001	418325	105	110	5	1.5	0.064
QS-TR-22-001	418327	110	115	5	1.5	0.095
QS-TR-22-001	418328	115	120	5	1.5	0.124
QS-TR-22-001	418329	120	125	5	1.5	0.071
QS-TR-22-001	418330	125	130	5	1.5	0.105
QS-TR-22-001	418331	130	135	5	1.5	0.089
QS-TR-22-001	418332	135	140	5	1.5	0.036
QS-TR-22-001	418333	140	145	5	1.5	0.134
QS-TR-22-001	418335	145	150	5	1.5	0.867
QS-TR-22-001	418336	150	155	5	1.5	0.149
QS-TR-22-001	418337	155	160	5	1.5	0.111
QS-TR-22-001	418338	160	165	5	1.5	0.109
QS-TR-22-001	418339	165	170	5	1.5	0.089

**TABLE APPENDIX K-1
QUEEN SPECIMEN 2022 TRENCH ASSAYS**

Trench ID	Sample ID	From (ft)	To (ft)	Length (ft)	Length (m)	Au (g/t)
QS-TR-22-001	418341	170	175	5	1.5	0.386
QS-TR-22-001	418342	175	180	5	1.5	0.180
QS-TR-22-001	418343	180	185	5	1.5	1.630
QS-TR-22-001	418344	185	188	2.5	1.5	0.384
QS-TR-22-001	418346	187.5	190	2.5	1.5	0.506
QS-TR-22-001	418347	190	193	3	1.5	1.610
QS-TR-22-001	418348	193	195	2	1.5	1.780
QS-TR-22-001	418349	195	200	5	1.5	0.299
QS-TR-22-001	418350	200	205	5	1.5	0.182
QS-TR-22-001	418351	205	210	5	1.5	0.764
QS-TR-22-001	418352	210	215	5	1.5	0.714
QS-TR-22-001	418353	215	220	5	1.5	0.152
QS-TR-22-001	418354	220	225	5	1.5	0.292
QS-TR-22-001	418356	225	230	5	1.5	0.422
QS-TR-22-001	418357	230	235	5	1.5	0.241
QS-TR-22-001	418359	235	240	5	1.5	0.120
QS-TR-22-001	418360	240	245	5	1.5	4.140
QS-TR-22-001	418361	245	250	5	1.5	0.081
QS-TR-22-001	418363	250	255	5	1.5	0.049
QS-TR-22-001	418364	255	260	5	1.5	0.012
QS-TR-22-001	418365	260	265	5	1.5	0.005
QS-TR-22-001	418366	265	270	5	1.5	0.077
QS-TR-22-001	418367	270	275	5	1.5	0.024
QS-TR-22-001	418368	275	280	5	1.5	0.011
QS-TR-22-001	418369	280	285	5	1.5	0.062
QS-TR-22-001	418370	285	290	5	1.5	0.032
QS-TR-22-001	418372	290	295	5	1.5	0.021
QS-TR-22-002	418434	0	5	5	1.5	0.242
QS-TR-22-002	418436	5	10	5	1.5	0.126
QS-TR-22-002	418437	10	15	5	1.5	0.130
QS-TR-22-002	418438	15	20	5	1.5	0.146
QS-TR-22-002	418439	20	25	5	1.5	0.186
QS-TR-22-002	418441	25	30	5	1.5	0.183
QS-TR-22-002	418442	30	35	5	1.5	0.151
QS-TR-22-002	418443	35	40	5	1.5	0.192
QS-TR-22-002	418444	40	45	5	1.5	0.392
QS-TR-22-002	418445	45	50	5	1.5	0.344
QS-TR-22-002	418446	50	55	5	1.5	1.100
QS-TR-22-002	418447	55	60	5	1.5	1.240

**TABLE APPENDIX K-1
QUEEN SPECIMEN 2022 TRENCH ASSAYS**

Trench ID	Sample ID	From (ft)	To (ft)	Length (ft)	Length (m)	Au (g/t)
QS-TR-22-002	418448	60	65	5	1.5	0.174
QS-TR-22-002	418449	65	70	5	1.5	0.238
QS-TR-22-002	418451	70	75	5	1.5	0.211
QS-TR-22-002	418452	75	80	5	1.5	0.238
QS-TR-22-002	418453	80	85	5	1.5	0.811
QS-TR-22-002	418454	85	90	5	1.5	0.726
QS-TR-22-002	418456	90	95	5	1.5	0.273
QS-TR-22-002	418457	95	100	5	1.5	0.239
QS-TR-22-002	418458	100	105	5	1.5	0.689
QS-TR-22-002	418459	105	110	5	1.5	0.474
QS-TR-22-002	418461	110	115	5	1.5	0.096
QS-TR-22-003	418505	0	5	5	1.5	0.163
QS-TR-22-003	418506	5	10	5	1.5	0.209
QS-TR-22-003	418507	10	15	5	1.5	0.165
QS-TR-22-003	418508	15	20	5	1.5	0.172
QS-TR-22-003	418509	20	25	5	1.5	0.166
QS-TR-22-003	418511	25	30	5	1.5	0.573
QS-TR-22-003	418512	30	35	5	1.5	2.250
QS-TR-22-003	418513	35	40	5	1.5	1.530
QS-TR-22-003	418514	40	45	5	1.5	0.471
QS-TR-22-003	418516	45	50	5	1.5	1.890
QS-TR-22-003	418517	50	55	5	1.5	0.163
QS-TR-22-003	418518	55	60	5	1.5	1.990
QS-TR-22-003	418519	60	65	5	1.5	2.470
QS-TR-22-003	418521	65	70	5	1.5	3.410
QS-TR-22-003	418522	70	75	5	1.5	1.620
QS-TR-22-003	418523	75	80	5	1.5	1.480
QS-TR-22-003	418524	80	85	5	1.5	0.773
QS-TR-22-003	418525	85	90	5	1.5	2.740
QS-TR-22-003	418526	90	95	5	1.5	0.315
QS-TR-22-003	418527	95	100	5	1.5	0.117
QS-TR-22-003	418528	100	105	5	1.5	0.127
QS-TR-22-003	418529	105	110	5	1.5	0.127
QS-TR-22-003	418531	110	115	5	1.5	0.133
QS-TR-22-003	418532	115	120	5	1.5	0.142
QS-TR-22-003	418533	120	125	5	1.5	0.119
QS-TR-22-003	418534	125	130	5	1.5	0.140
QS-TR-22-003	418536	130	135	5	1.5	0.107
QS-TR-22-003	418537	135	140	5	1.5	0.134

**TABLE APPENDIX K-1
QUEEN SPECIMEN 2022 TRENCH ASSAYS**

Trench ID	Sample ID	From (ft)	To (ft)	Length (ft)	Length (m)	Au (g/t)
QS-TR-22-003	418538	140	145	5	1.5	0.099
QS-TR-22-003	418539	145	150	5	1.5	0.122
QS-TR-22-003	418541	150	155	5	1.5	0.076
QS-TR-22-003	418542	155	160	5	1.5	0.070
QS-TR-22-003	418543	160	165	5	1.5	0.201
QS-TR-22-003	418544	165	170	5	1.5	0.223
QS-TR-22-003	418545	170	175	5	1.5	0.067
QS-TR-22-003	418546	175	180	5	1.5	0.092
QS-TR-22-003	418547	180	185	5	1.5	0.088
QS-TR-22-003	418548	185	190	5	1.5	0.076
QS-TR-22-003	418549	190	195	5	1.5	0.088
QS-TR-22-003	418551	195	200	5	1.5	0.070
QS-TR-22-003	418552	200	205	5	1.5	0.073
QS-TR-22-003	418553	205	210	5	1.5	0.100
QS-TR-22-003	418554	210	215	5	1.5	0.130
QS-TR-22-003	418556	215	220	5	1.5	0.158
QS-TR-22-003	418557	220	225	5	1.5	0.108
QS-TR-22-003	418558	225	230	5	1.5	0.168
QS-TR-22-003	418559	230	235	5	1.5	0.160
QS-TR-22-003	418562	240	245	5	1.5	0.377
QS-TR-22-003	418563	245	250	5	1.5	0.340
QS-TR-22-003	418564	250	255	5	1.5	0.246
QS-TR-22-003	418565	255	260	5	1.5	0.257
QS-TR-22-003	418566	260	265	5	1.5	0.190
QS-TR-22-003	418567	265	270	5	1.5	0.184
QS-TR-22-003	418568	270	275	5	1.5	0.309
QS-TR-22-003	418569	275	280	5	1.5	0.496
QS-TR-22-003	418571	280	285	5	1.5	0.412
QS-TR-22-003	418572	285	290	5	1.5	0.424
QS-TR-22-003	418573	290	295	5	1.5	0.230
QS-TR-22-004	418624	0	5	5	1.5	0.021
QS-TR-22-004	418625	5	10	5	1.5	0.028
QS-TR-22-004	418626	10	15	5	1.5	0.026
QS-TR-22-004	418627	15	20	5	1.5	0.151
QS-TR-22-004	418628	20	25	5	1.5	0.022
QS-TR-22-004	418629	25	30	5	1.5	0.022
QS-TR-22-004	418631	30	35	5	1.5	0.024
QS-TR-22-004	418632	35	40	5	1.5	0.025
QS-TR-22-004	418633	40	45	5	1.5	0.038

**TABLE APPENDIX K-1
QUEEN SPECIMEN 2022 TRENCH ASSAYS**

Trench ID	Sample ID	From (ft)	To (ft)	Length (ft)	Length (m)	Au (g/t)
QS-TR-22-004	418634	45	50	5	1.5	0.164
QS-TR-22-004	418636	50	55	5	1.5	0.076
QS-TR-22-004	418637	55	60	5	1.5	0.029
QS-TR-22-004	418638	60	65	5	1.5	0.036
QS-TR-22-004	418639	65	70	5	1.5	0.277
QS-TR-22-004	418641	70	75	5	1.5	0.407
QS-TR-22-004	418642	75	80	5	1.5	0.131
QS-TR-22-004	418643	80	85	5	1.5	0.047
QS-TR-22-004	418644	85	90	5	1.5	0.061
QS-TR-22-005	418574	5	10	5	1.5	0.744
QS-TR-22-005	418576	10	15	5	1.5	0.888
QS-TR-22-005	418577	15	20	5	1.5	0.437
QS-TR-22-005	418578	20	25	5	1.5	0.526
QS-TR-22-005	418579	25	30	5	1.5	0.281
QS-TR-22-005	418581	30	35	5	1.5	0.267
QS-TR-22-005	418582	35	40	5	1.5	0.189
QS-TR-22-005	418583	40	45	5	1.5	0.393
QS-TR-22-005	418584	45	50	5	1.5	0.514
QS-TR-22-005	418585	50	55	5	1.5	0.582
QS-TR-22-005	418586	55	60	5	1.5	0.457
QS-TR-22-005	418587	60	65	5	1.5	0.597
QS-TR-22-005	418588	65	70	5	1.5	0.695
QS-TR-22-005	418589	70	75	5	1.5	1.100
QS-TR-22-005	418591	75	80	5	1.5	3.440
QS-TR-22-005	418592	80	85	5	1.5	0.400
QS-TR-22-005	418593	85	90	5	1.5	0.517
QS-TR-22-005	418596	90	95	5	1.5	0.928
QS-TR-22-005	418597	95	100	5	1.5	0.269
QS-TR-22-005	418598	100	105	5	1.5	0.315
QS-TR-22-005	418599	105	110	5	1.5	0.400
QS-TR-22-005	418601	110	115	5	1.5	0.311
QS-TR-22-005	418602	115	120	5	1.5	0.325
QS-TR-22-005	418603	120	125	5	1.5	0.227
QS-TR-22-005	418604	125	130	5	1.5	0.326
QS-TR-22-005	418605	130	135	5	1.5	0.199
QS-TR-22-005	418606	135	140	5	1.5	0.155
QS-TR-22-005	418607	140	145	5	1.5	1.480
QS-TR-22-005	418608	145	150	5	1.5	1.550
QS-TR-22-005	418609	150	155	5	1.5	0.469

**TABLE APPENDIX K-1
QUEEN SPECIMEN 2022 TRENCH ASSAYS**

Trench ID	Sample ID	From (ft)	To (ft)	Length (ft)	Length (m)	Au (g/t)
QS-TR-22-005	418611	155	160	5	1.5	0.384
QS-TR-22-005	418612	160	165	5	1.5	2.030
QS-TR-22-005	418613	165	170	5	1.5	1.020
QS-TR-22-005	418614	170	175	5	1.5	0.275
QS-TR-22-005	418616	175	180	5	1.5	0.587
QS-TR-22-005	418617	180	185	5	1.5	1.880
QS-TR-22-005	418618	185	190	5	1.5	1.710
QS-TR-22-005	418619	190	195	5	1.5	0.373
QS-TR-22-005	418621	195	200	5	1.5	0.323
QS-TR-22-005	418622	200	205	5	1.5	0.212
QS-TR-22-005	418623	205	210	5	1.5	0.222
QS-TR-22-006	421703	0	5	5	1.5	0.046
QS-TR-22-006	421704	5	10	5	1.5	0.047
QS-TR-22-006	421705	10	15	5	1.5	0.101
QS-TR-22-006	421706	15	20	5	1.5	0.074
QS-TR-22-006	421707	20	25	5	1.5	0.052
QS-TR-22-006	421708	25	30	5	1.5	0.030
QS-TR-22-006	421709	30	35	5	1.5	0.015
QS-TR-22-006	421710	35	40	5	1.5	0.044
QS-TR-22-006	421712	40	45	5	1.5	0.057
QS-TR-22-006	421713	45	50	5	1.5	0.028
QS-TR-22-006	421714	50	55	5	1.5	0.046
QS-TR-22-006	421715	55	60	5	1.5	0.135
QS-TR-22-006	421716	60	65	5	1.5	0.072
QS-TR-22-006	421717	65	70	5	1.5	0.078
QS-TR-22-006	421718	70	75	5	1.5	0.048
QS-TR-22-006	421719	75	80	5	1.5	0.079
QS-TR-22-006	421720	80	85	5	1.5	0.106
QS-TR-22-006	421722	85	90	5	1.5	0.113
QS-TR-22-006	421723	90	95	5	1.5	0.128
QS-TR-22-006	421724	95	100	5	1.5	0.151
QS-TR-22-006	421725	100	105	5	1.5	0.128
QS-TR-22-006	421727	105	110	5	1.5	0.126
QS-TR-22-006	421728	110	115	5	1.5	0.074
QS-TR-22-006	421729	115	120	5	1.5	0.535
QS-TR-22-006	421730	120	125	5	1.5	0.107
QS-TR-22-006	421732	125	130	5	1.5	0.149
QS-TR-22-006	421733	130	135	5	1.5	0.178
QS-TR-22-006	421734	135	140	5	1.5	0.085

**TABLE APPENDIX K-1
QUEEN SPECIMEN 2022 TRENCH ASSAYS**

Trench ID	Sample ID	From (ft)	To (ft)	Length (ft)	Length (m)	Au (g/t)
QS-TR-22-006	421735	140	145	5	1.5	0.056
QS-TR-22-006	421736	145	150	5	1.5	0.112
QS-TR-22-006	421737	150	155	5	1.5	0.289
QS-TR-22-006	421738	155	160	5	1.5	0.273
QS-TR-22-006	421739	160	165	5	1.5	0.396
QS-TR-22-006	421740	165	170	5	1.5	0.221
QS-TR-22-006	421742	170	175	5	1.5	0.355
QS-TR-22-006	421743	175	181	6	1.5	0.206
QS-TR-22-006	421744	181	185	4	1.5	0.034
QS-TR-22-006	421745	185	190	5	1.5	0.023
QS-TR-22-006	421746	190	195	5	1.5	0.117
QS-TR-22-006	421747	195	200	5	1.5	0.355
QS-TR-22-006	421748	200	205	5	1.5	0.386
QS-TR-22-006	421749	205	210	5	1.5	0.230
QS-TR-22-006	421750	210	215	5	1.5	0.163
QS-TR-22-006	421752	215	220	5	1.5	0.221
QS-TR-22-006	421753	220	225	5	1.5	0.110
QS-TR-22-006	421754	225	230	5	1.5	0.098
QS-TR-22-006	421755	230	235	5	1.5	0.218
QS-TR-22-008	418462	0	5	5	1.5	1.920
QS-TR-22-008	418463	5	10	5	1.5	1.140
QS-TR-22-008	418464	10	15	5	1.5	1.170
QS-TR-22-008	418465	15	20	5	1.5	1.710
QS-TR-22-008	418466	20	25	5	1.5	0.552
QS-TR-22-008	418467	25	30	5	1.5	0.579
QS-TR-22-008	418468	30	35	5	1.5	0.195
QS-TR-22-008	418469	35	40	5	1.5	0.241
QS-TR-22-008	418471	40	45	5	1.5	0.122
QS-TR-22-008	418472	45	50	5	1.5	0.645
QS-TR-22-008	418473	50	55	5	1.5	0.155
QS-TR-22-008	418474	55	60	5	1.5	0.182
QS-TR-22-008	418476	60	65	5	1.5	0.867
QS-TR-22-008	418477	65	70	5	1.5	1.840
QS-TR-22-008	418478	70	75	5	1.5	0.181
QS-TR-22-008	418479	75	80	5	1.5	0.218
QS-TR-22-008	418481	80	85	5	1.5	0.325
QS-TR-22-008	418482	85	90	5	1.5	1.490
QS-TR-22-008	418483	90	95	5	1.5	0.414
QS-TR-22-008	418484	95	100	5	1.5	0.413

**TABLE APPENDIX K-1
QUEEN SPECIMEN 2022 TRENCH ASSAYS**

Trench ID	Sample ID	From (ft)	To (ft)	Length (ft)	Length (m)	Au (g/t)
QS-TR-22-008	418485	100	105	5	1.5	1.190
QS-TR-22-008	418486	105	110	5	1.5	0.339
QS-TR-22-008	418487	110	115	5	1.5	0.886
QS-TR-22-008	418488	115	120	5	1.5	0.872
QS-TR-22-008	418489	120	125	5	1.5	1.090
QS-TR-22-008	418491	125	130	5	1.5	1.020
QS-TR-22-008	418492	130	135	5	1.5	0.321
QS-TR-22-008	418493	135	140	5	1.5	0.377
QS-TR-22-008	418494	140	145	5	1.5	0.336
QS-TR-22-008	418496	145	150	5	1.5	0.384
QS-TR-22-008	418497	150	155	5	1.5	0.288
QS-TR-22-008	418498	155	160	5	1.5	0.295
QS-TR-22-008	418499	160	165	5	1.5	0.851
QS-TR-22-008	418501	165	170	5	1.5	2.700
QS-TR-22-008	418502	170	175	5	1.5	1.000
QS-TR-22-008	418503	175	180	5	1.5	0.685
QS-TR-22-008	418504	180	185	5	1.5	0.892
QS-TR-22-009	418374	0	5	5	1.5	0.110
QS-TR-22-009	418376	5	10	5	1.5	0.090
QS-TR-22-009	418377	10	15	5	1.5	0.129
QS-TR-22-009	418378	15	20	5	1.5	0.159
QS-TR-22-009	418379	20	25	5	1.5	0.195
QS-TR-22-009	418381	25	30	5	1.5	0.173
QS-TR-22-009	418382	30	35	5	1.5	0.269
QS-TR-22-009	418383	35	40	5	1.5	0.397
QS-TR-22-009	418384	40	45	5	1.5	0.185
QS-TR-22-009	418386	45	50	5	1.5	0.158
QS-TR-22-009	418387	50	55	5	1.5	0.126
QS-TR-22-009	418388	55	60	5	1.5	0.132
QS-TR-22-009	418389	60	65	5	1.5	0.100
QS-TR-22-009	418391	65	70	5	1.5	0.113
QS-TR-22-009	418392	70	75	5	1.5	0.174
QS-TR-22-009	418393	75	80	5	1.5	0.343
QS-TR-22-009	418394	80	85	5	1.5	0.191
QS-TR-22-009	418396	85	90	5	1.5	0.187
QS-TR-22-009	418397	90	95	5	1.5	0.096
QS-TR-22-009	418398	95	100	5	1.5	0.581
QS-TR-22-009	418399	100	105	5	1.5	1.480
QS-TR-22-009	418401	105	110	5	1.5	0.465

**TABLE APPENDIX K-1
QUEEN SPECIMEN 2022 TRENCH ASSAYS**

Trench ID	Sample ID	From (ft)	To (ft)	Length (ft)	Length (m)	Au (g/t)
QS-TR-22-009	418402	110	115	5	1.5	0.307
QS-TR-22-009	418403	115	120	5	1.5	3.730
QS-TR-22-009	418404	120	125	5	1.5	0.294
QS-TR-22-009	418405	125	130	5	1.5	0.195
QS-TR-22-009	418406	130	135	5	1.5	0.166
QS-TR-22-009	418407	135	140	5	1.5	0.132
QS-TR-22-009	418408	140	145	5	1.5	0.146
QS-TR-22-009	418409	145	150	5	1.5	0.131
QS-TR-22-009	418411	150	155	5	1.5	0.188
QS-TR-22-009	418412	155	160	5	1.5	0.161
QS-TR-22-009	418413	160	165	5	1.5	0.175
QS-TR-22-009	418414	165	170	5	1.5	0.183
QS-TR-22-009	418416	170	175	5	1.5	0.158
QS-TR-22-009	418417	175	180	5	1.5	0.177
QS-TR-22-009	418418	180	185	5	1.5	0.179
QS-TR-22-009	418419	185	190	5	1.5	0.161
QS-TR-22-009	418421	190	195	5	1.5	0.141
QS-TR-22-009	418422	195	200	5	1.5	0.074
QS-TR-22-009	418423	200	205	5	1.5	0.219
QS-TR-22-009	418424	205	210	5	1.5	0.184
QS-TR-22-009	418425	210	215	5	1.5	0.160
QS-TR-22-009	418426	215	220	5	1.5	0.143
QS-TR-22-009	418427	220	225	5	1.5	0.201
QS-TR-22-009	418428	225	230	5	1.5	0.162
QS-TR-22-009	418429	230	235	5	1.5	0.142
QS-TR-22-009	418431	235	240	5	1.5	0.086
QS-TR-22-009	418432	240	245	5	1.5	0.111
QS-TR-22-009	418433	245	250	5	1.5	0.413

Source: Stratabound (2022)